

INSTRUCTION MANUAL

Serial Number _____

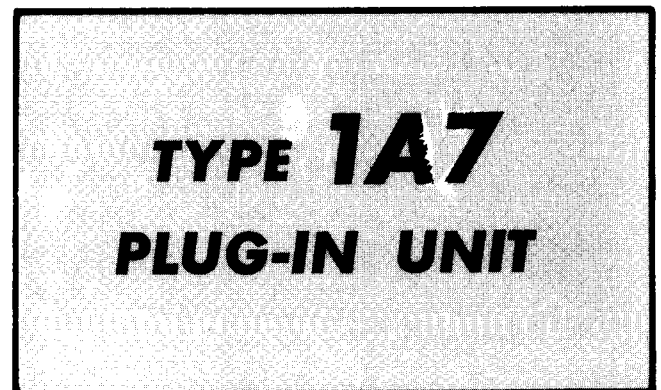

Tektronix, Inc.

S.W. Millikan Way ● P. O. Box 500 ● Beaverton, Oregon 97005 ● Phone 644-0161 ● Cables: Tektronix

070-0379-00

1065



WARRANTY

All Tektronix instruments are warranted against defective materials and workmanship for one year. Tektronix transformers, manufactured in our own plant, are warranted for the life of the instrument.

Any questions with respect to the warranty mentioned above should be taken up with your Tektronix Field Engineer.

Tektronix repair and replacement-part service is geared directly to the field, therefore all requests for repairs and replacement parts should be directed to the Tektronix Field Office or Representative in your area. This procedure will assure you the fastest possible service. Please include the instrument Type and Serial number with all requests for parts or service.

Specifications and price change privileges reserved.

Copyright © 1965 by Tektronix, Inc., Beaverton, Oregon. Printed in the United States of America. All rights reserved. Contents of this publication may not be reproduced in any form without permission of the copyright owner.



CONTENTS

- Section 1 Characteristics
- Section 2 Operating Instructions
- Section 3 Circuit Description
- Section 4 Maintenance
- Section 5 Performance Check
- Section 6 Calibration
- Section 7 Electrical Parts List
- Section 8 Mechanical Parts List
- Section 9 Diagrams

A list of abbreviations and symbols used in this manual will be found immediately preceding Section 7. Change information, if any, is located at the rear of the manual.

PATENTS PENDING
TEKTRONIX, INC.

R519

VOLTS/CM
VARIABLE

TYPE 1A7 PLUG-IN UNIT
HIGH-GAIN DIFFERENTIAL AMPLIFIER

50 20 10 5 mVOLTS
1 2
500
200
100
50
20
10
5
10
VOLTS
CALIBRATED

POSITION

HIGH FREQ 3dB POINT
LOW FREQ 3dB POINT
3kHz 10kHz
1kHz 1 10 100 30kHz
1kHz
100kHz
10kHz
500kHz
300
DC
100

INPUT OVERLOAD

GAIN

DC OFFSET FINE ON OFF

+ INPUT
1MΩ 47pF
AC
GND
DC

COARSE
STEP ATTEN
DC BAL
FINE

DC OFFSET FINE ON OFF

- INPUT
1MΩ 47pF
AC
GND
DC

SIGNAL OUTPUT



TEKTRONIX, INC.

SERIAL
PORTLAND, OREGON, U.S.A.

Fig. 1-1. The Type 1A7 Plug-In Unit.

SECTION 1

CHARACTERISTICS

General Information

The Type 1A7 is a high-gain low-noise adjustable bandwidth dc-coupled differential amplifier. This unit is designed for use in all Tektronix 530-, 540-, 550-, and 580¹-Series oscilloscopes and their rackmount equivalents. The Type 1A7 can also be used in conjunction with other oscilloscopes and devices through the use of a Tektronix Type 127, 132 or 133 plug-in power supply.

Minimum deflection factor of the unit is 10 $\mu\text{V}/\text{cm}$. Maximum bandwidth is dc to 500 kHz at all deflection factors. When operating as a differential amplifier, the Type 1A7 has a stable common-mode rejection ratio (CMRR) of 50,000:1 or greater for dc to 100-kHz common-mode signals up to ± 10 volts in amplitude.

Sensitivity

Nineteen calibrated deflection factors in a 1-2-5 sequence from 10 $\mu\text{V}/\text{cm}$ to 10 V/cm.

The front-panel VARIABLE control has a 2.5:1 ratio or higher to provide continuously variable uncalibrated deflection factor range from 10 $\mu\text{V}/\text{cm}$ to at least 25 V/cm.

Gain Calibration Accuracy

A 10 $\mu\text{V}/\text{cm}$ internal adjustment and a 10 mV/cm front-panel adjustment are provided to set the gain of the unit. When these adjustments are accurately set, the calibrated deflection factor accuracies at room ambient temperature (25° C $\pm 5^\circ$ C) are summarized in Table 1-1.

TABLE 1-1

VOLTS/CM Switch Position	Accuracy
10 $\mu\text{V}/\text{cm}$	Adjusted
20 $\mu\text{V}/\text{cm}$ to 50 $\mu\text{V}/\text{cm}$	$\pm 2\%$
100 $\mu\text{V}/\text{cm}$ to 5 mV/cm	$\pm 1.5\%$
10 mV/cm	Adjusted
20 $\mu\text{V}/\text{cm}$ to 10 mV/cm	$\pm 2\%$

Gain Variation With Temperature

See Table 1-2. Accuracies apply at 0° C to 50° C ambient temperature after the gain adjustments are set properly at 25° C. Significant reduction in gain occurs only at temperatures below 15° C ambient, becoming most severe at 0° ambient.

TABLE 1-2

VOLTS/CM Switch Position	Accuracy
10 $\mu\text{V}/\text{cm}$	-8%, +2%
20 $\mu\text{V}/\text{cm}$ to 100 $\mu\text{V}/\text{cm}$	-4%, +1%
200 $\mu\text{V}/\text{cm}$ to 10 V/cm	$\pm 1\%$

¹580-Series oscilloscopes require a Type 81 Adapter.

High Frequency Response

See Table 1-3 and Fig. 1-2.

TABLE 1-3

HIGH FREQ 3 dB POINT	
Switch Position	Accuracy
500 kHz	$\pm 20\%$
100 kHz to 100 Hz	$\pm 12\%$

Low Frequency Response

See Table 1-4 and Fig. 1-3.

TABLE 1-4

LOW FREQ 3 dB POINT	
Switch Position	Accuracy
DC	Not applicable
0.1 Hz to 100 Hz	$\pm 30\%$
1 kHz and 10 kHz	$\pm 12\%$

Transient Response

$\leq \pm 2\%$ aberration any bandwidth.

Maximum Allowable Input Voltage Rating

See Table 1-5.

TABLE 1-5

Maximum Input Voltage

VOLTS/CM Switch Position	Combined DC and Peak 60 Hz AC	
	(DC coupled)	(AC coupled)
10 $\mu\text{V}/\text{cm}$ to 10 mV/cm	200 V	600 V
20 mV/cm to 10 V/cm	600 V	600 V

Maximum Common-Mode Input Voltage

See Table 1-6.

TABLE 1-6

VOLTS/CM Switch Position	Combined DC and Peak AC (DC coupled)	Peak AC (AC coupled)
10 $\mu\text{V}/\text{cm}$ to 10 mV/cm	$\pm 10 \text{ V}^2$	10 Vac, 600 Vdc
20 mV/cm to 0.1 V/cm	$\pm 100 \text{ V}^2$	100 Vac, 600 Vdc
0.2 V/cm to 10 V/cm	600 V	600 Vac, 600 Vdc

²For ambient temperature below 30° C the common-mode input voltage rating from 10 $\mu\text{V}/\text{cm}$ to 0.1 V/cm may be doubled with no appreciable effect on CMRR. The common-mode dynamic range is then $\pm 20 \text{ V}$ or 40 V peak to peak from 10 $\mu\text{V}/\text{cm}$ to 10 mV/cm.

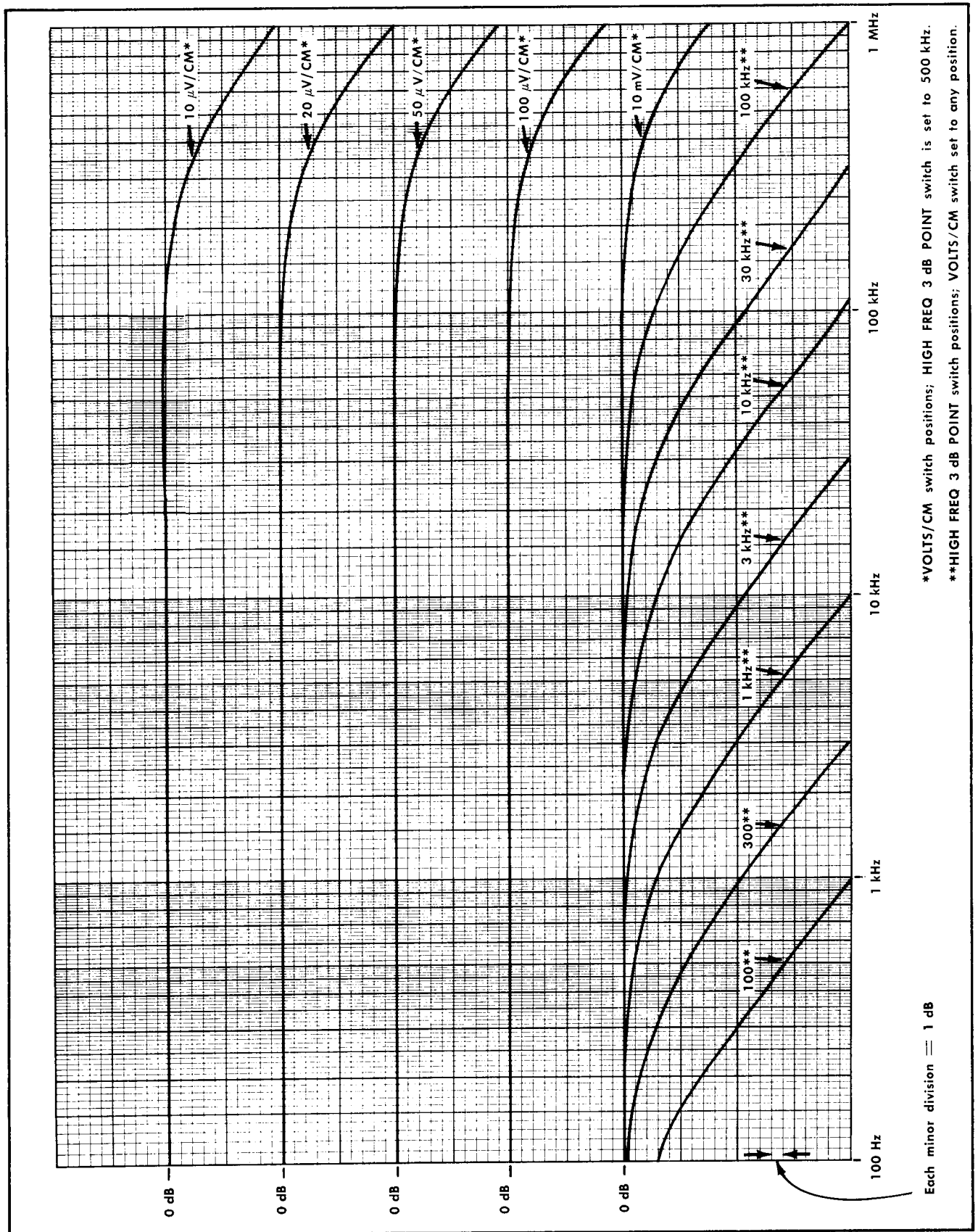

*VOLTS/CM switch positions; HIGH FREQ 3 dB POINT switch is set to 500 kHz.
 **HIGH FREQ 3 dB POINT switch positions; VOLTS/CM switch set to any position.

Each minor division = 1 dB

Fig. 1-2. Typical high frequency response of the Type 1A7 as a function of the HIGH FREQ 3 dB POINT and VOLTS/CM switch settings. The LOW FREQ 3 dB POINT switch is set to DC for all the curves.

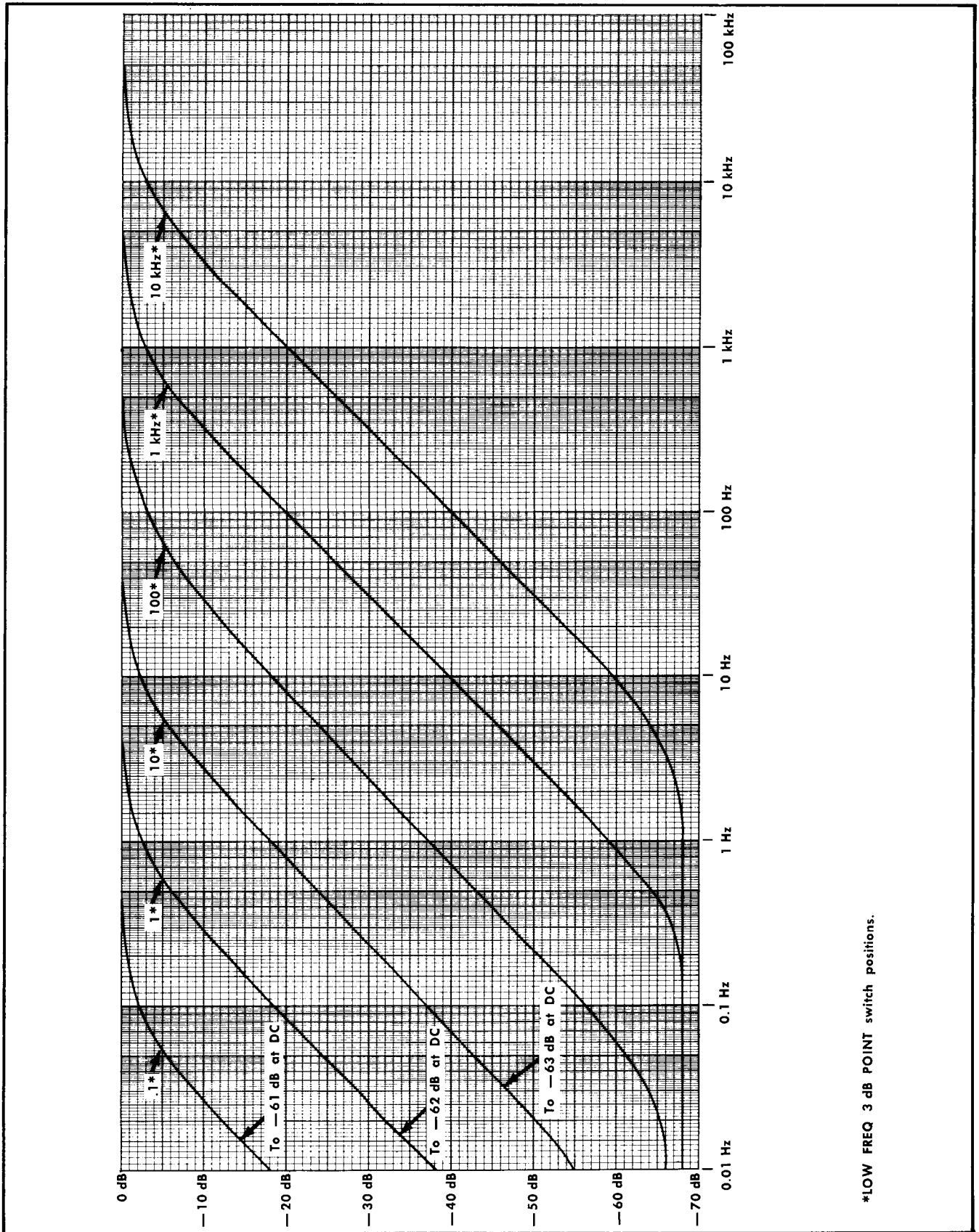

Fig. 1-3. Typical low frequency response of the Type 1A7 as a function of the LOW FREQ 3 dB POINT switch setting (ac stabilization mode). The HIGH FREQ 3 dB POINT switch is set to 500 kHz for all curves.

Characteristics—Type 1A7

Common-Mode Rejection Ratio (CMRR)

See Table 1-7 and Fig. 1-4. Characteristics apply at 25° C ±5° C.

TABLE 1-7

Peak-to-Peak Sine-Wave Common-Mode Signal	Input Coupling Switch	VOLTS/CM Switch Position	CMRR ³
Dc to 20 kHz, ≤20 V	DC	10 μV/cm to 10 mV/cm	Adjustable to ≥310,000:1
Dc to 100 kHz ≤20 V	DC	10 μV/cm to 10 mV/cm	≥50,000:1
Dc to 1 kHz, ≤200 V	DC	20 mV/cm to 10 V/cm	Adjustable to ≥5,000:1
1 kc to 100 kHz, ≤200 V	DC	20 mV/cm to 10 V/cm	Adjustable to ≥500:1
60 Hz, 20 V	AC	10 μV/cm to 10 mV/cm	≥2,000:1
60 Hz, 200 V	AC	20 mV/cm to 10 V/cm	

³Checked by applying a sine wave from an audio generator to both inputs on the Type 1A7. Set generator frequency and amplitude as specified in column 1 of the table. Set input coupling switches as directed in column 2 and check CMRR at each VOLTS/CM switch position. CMRR is the common-mode signal amplitude divided by the signal voltage displayed on the crt. Checked with DC OFFSET ON-OFF switch set to OFF.

Input Coupling Modes

Ac or dc, selected by front-panel switch.

A third position, GND, is provided to ground the amplifier input without grounding the signal source. Also, permits precharging the ac-coupling capacitor (see Section 2).

Input Coupling AC Low Frequency Response

−3 dB at 1.6 Hz.

With AC-GND-DC switch set to AC and the input driven from a source impedance which is negligible when compared with 1 megohm.

Input R and C

One megohm ±0.75% paralleled by 47 pF ±1.5%.

The 1-megohm input resistance can be eliminated to provide floating inputs when any of the ten most sensitive ranges (10 μV/cm to 10 mV/cm) are used for dc-coupled signals. Removable wire links are provided for this purpose on the attenuator etched wiring board. See Section 2.

Input Cross Neutralization

≤3% aberration.

Measured when driven grid is dc coupled and input coupling switch for undriven grid is set from GND to DC. Aberration on the display is expressed as a percentage of the original displayed amplitude.

Grid Current

Typically < 1 nanoamp (adjustable to zero) after a 20-minute warm up.

An internal calibration control diverts the grid current away from the input connector (except when the floating-input provision is used). The range of this control is adequate to divert up to 10 nanoamps.

Drift With Time: ≤ 20 picoamps/hr with ambient temperature and line voltage held constant, averaged over a 10-hour period.

Drift With Temperature: ≤ 50 picoamps/°C.

Dc Drift

With Time: ≤ 200 μV/hr with ambient temperature and line voltage held constant, averaged over a 10-hour period.

With Temperature: ≤ 150 μV/°C.

Dc Offset

See Table 1-8.

TABLE 1-8

VOLTS/CM Switch Position	Combined Coarse and Fine Range (+11%, −10%)	Input Attenuator Switched In
10 μV/cm to 10 mV/cm	±300 mV	X1
20 mV/cm to .1 V/cm	±3 V	X10
0.2 V/cm to 1 V/cm	±30 V	X100
2 V/cm to 10 V/cm	±300 V	X1000

VARIABLE (VOLTS/CM) Dc Balance

3 mm maximum trace shift.

Shift in position of trace when VARIABLE control is rotated from detent to the fully counterclockwise position; with STEP ATTEN DC BAL FINE control properly adjusted and DC OFFSET ON-OFF switch set to OFF.

Equivalent Wide-Band Short-Circuit Input Noise Voltage

3.3 μV rms maximum above 5 Hz. See Fig. 1-5.

Equivalent Wideband Short Circuit Noise Resistance

≤ 800 ohms. See Fig. 1-5.

Equal to 10.2 mV rms at SIGNAL OUTPUT connector with VOLTS/CM switch set to 10 μV, LOW FREQ 3 dB POINT switch set to DC and HIGH FREQ 3 dB POINT switch set to 500 kHz.

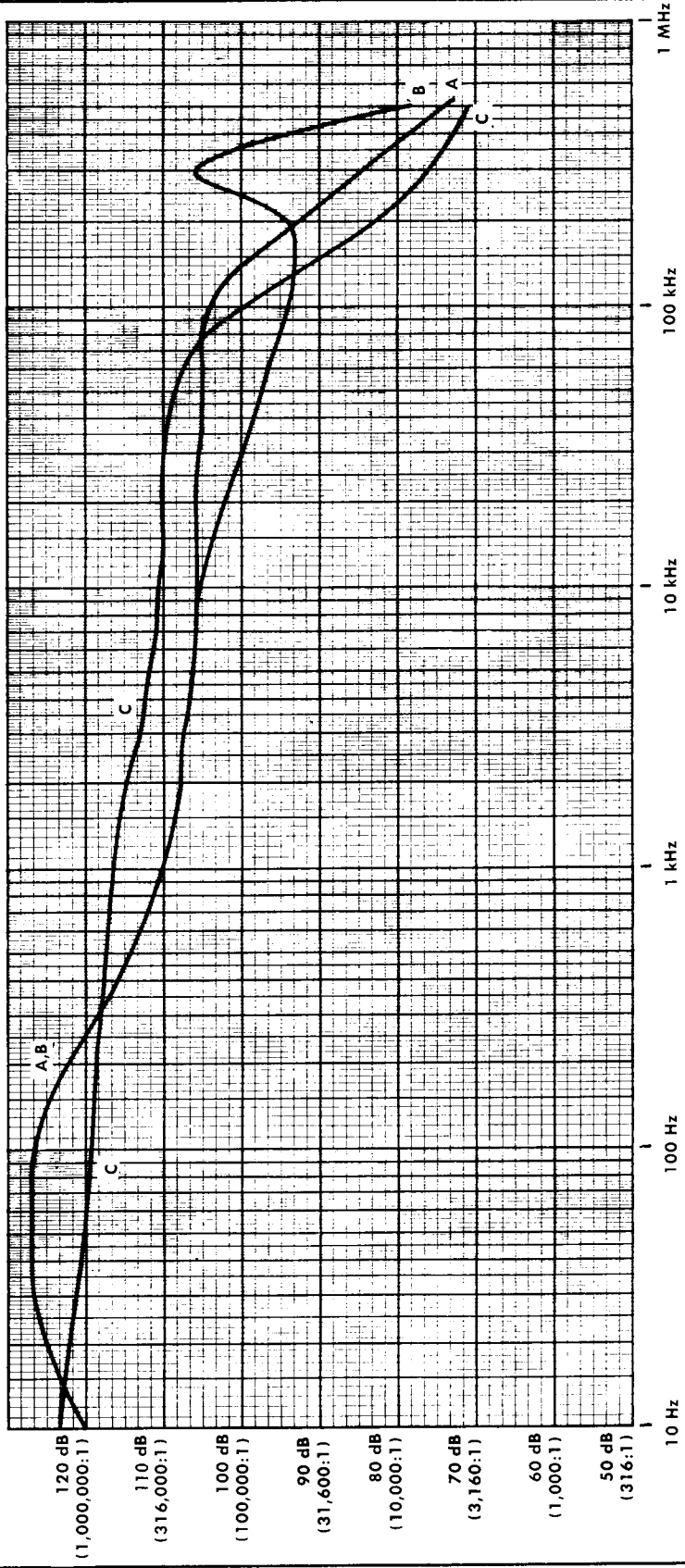

NOTE

A—Adjusted for maximum CMRR at 100 kHz.

B—Adjusted for maximum CMRR at 300 kHz.

C—Adjusted for maximum CMRR from DC-20 kHz.

±5 V (10 V p-p) common-mode signal is dc-coupled to the Type 1A7 amplifier at 100 μ V/CM. The curves are essentially the same if 20 V p-p is applied.

Fig. 1-4. Typical CMRR vs frequency curves for the Type 1A7.

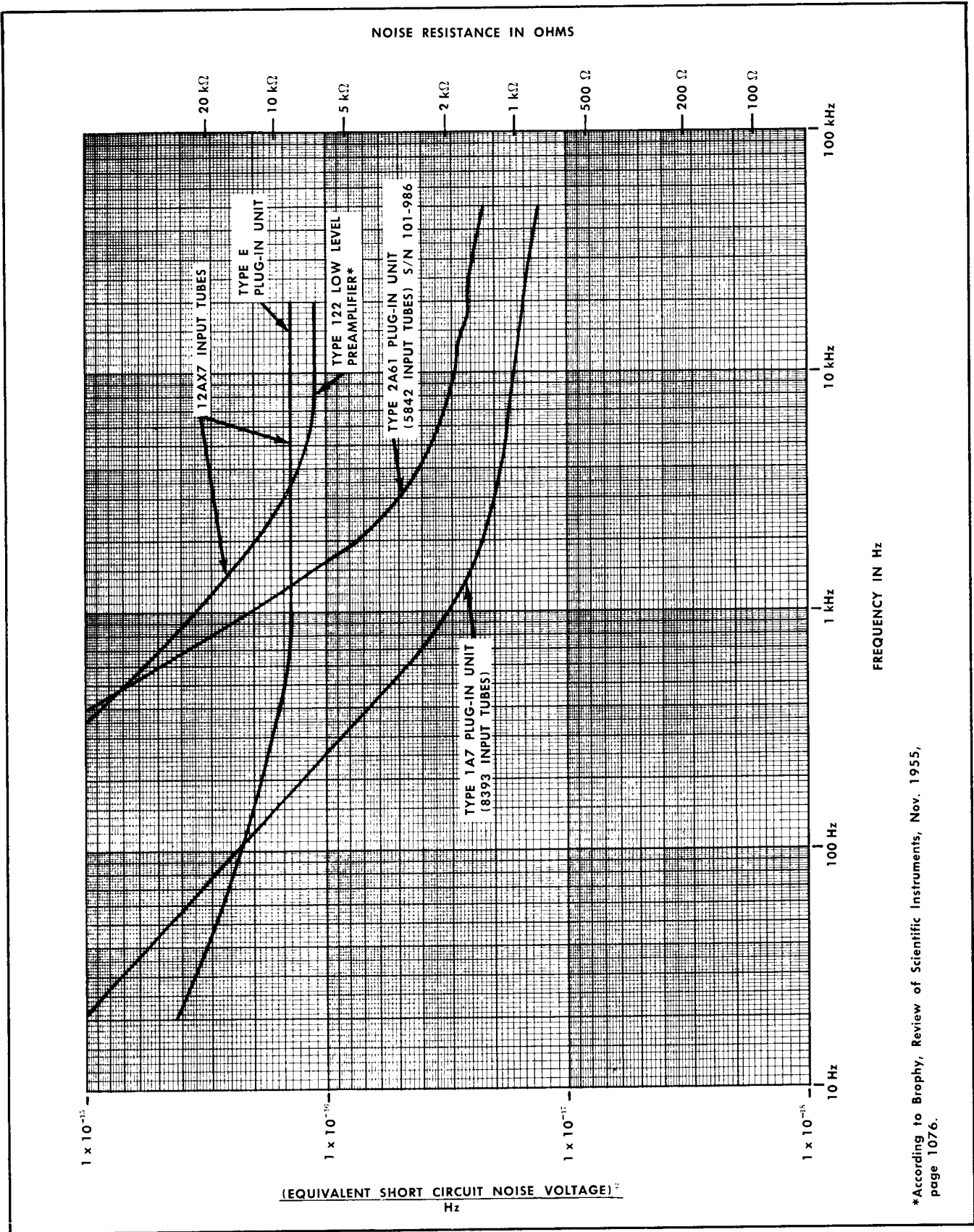

*According to Brophy, Review of Scientific Instruments, Nov. 1955, page 1076.

Fig. 1-5. Noise spectrum curves comparing the Type 1A7 with other Tektronix differential amplifiers.

NOTE

When an average reading rms calibrated voltmeter is used, a correction factor of 1.13 must be applied to the noise measurement. Multiply the reading by 1.13 to obtain a true rms value.

Signal Output

Dc Level: 0 volts at center screen. Internally adjustable to ground reference.

Amplitude: 34 mV, $\pm 10\%$ per display cm.

Frequency Response: Direct coupled, reproduces signal display on crt.

Output Impedance: 250 ohms $\pm 20\%$.

Environmental

Storage: -40°C to $+65^{\circ}\text{C}$, to 50,000 ft.

Operating Temperature: 0° to $+50^{\circ}\text{C}$.

Operating Altitude: To 50,000 ft.

Mechanical

Construction: Aluminum-alloy chassis and front panel. Glass laminate etched-wiring boards.

Finish: Anodized front panel.

Accessories Included

Information on accessories for use with this instrument is included at the rear of the mechanical parts list.

SECTION 2

OPERATING INSTRUCTIONS

FRONT PANEL

Introduction

A brief functional description is given of the front-panel controls, INPUT OVERLOAD light, input connectors, securing rod and SIGNAL OUTPUT connector.

INPUT OVERLOAD	Input overload indicator light. Turns on to indicate excessive dc differential drive to the input amplifier stage. Approximately 230 mV between input connectors at deflection factors from 10 μ V/cm to 10 mV/cm causes the light to turn on.
VOLTS/CM	Volts per centimeter (charcoal knob). Nineteen-position switch used to select the calibrated deflection factors.
VARIABLE	Variable volts per centimeter (red knob). Provides continuously variable uncalibrated attenuation between the calibrated deflection factors and extends the attenuation range to at least 25 V/cm. This control has a switch detent position for the CALIBRATED operation.
GAIN	Screwdriver-adjust control to set the gain of the amplifier so the crt deflection will agree with VOLTS/CM switch indication. Adjusted for proper deflection when the VOLTS/CM switch is set to the 10 mVOLTS position.
POSITION	A control that varies the vertical position of the trace or display.
HIGH FREQ 3 dB POINT	Eight-position switch (red knob) to select the approximate high-frequency 3-dB down points. The switch positions are: 100 and 300 Hz; 1, 3, 10, 30, 100 and 500 kHz.
LOW FREQ 3 dB POINT	Seven-position switch (charcoal knob) to select the low-frequency 3-dB down points. The switch positions are: DC; .1, 1, 10 and 100 Hz; 1 and 10 kHz. All positions are approximate 3-dB down points except the DC position which is exactly 0 dB.
+INPUT	Signal input connector. Positive input produces positive deflection (see Fig. 2-1).
-INPUT	Signal input connector. Positive input produces negative deflection (see Fig. 2-1).
AC-GND-DC (+INPUT coupling)	Three-position switch to select input coupling. AC and DC positions determine whether input signals applied to the +INPUT connector are ac or dc coupled to the Type 1A7 amplifier. The GND position disconnects the input signal and internally grounds the +input circuit, but presents the same load to the circuit under test. Also permits coupling capacitor to charge before switching to AC.

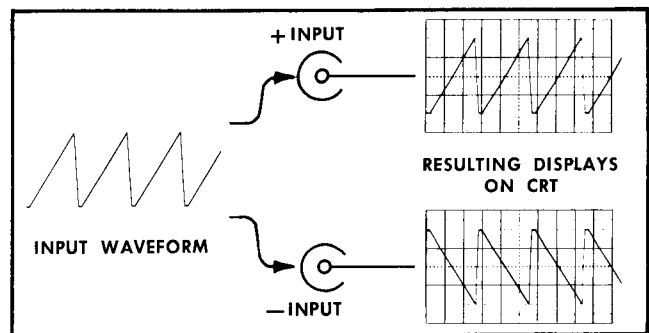

Fig. 2-1. Waveforms applied to the +INPUT connector produce an upright display, while waveforms applied to the -INPUT are inverted.

AC-GND-DC (-INPUT coupling) Same function as +INPUT coupling switch but applies to the -INPUT.

STEP ATTEN DC BAL (COARSE and FINE controls) Front-panel COARSE and FINE controls for dc balancing the amplifier input stage.

IMPORTANT

These controls are operative only when the LOW FREQ 3 dB POINT switch is set to DC.

STEP ATTEN DC BAL COARSE—A screwdriver-adjust control that serves as a very coarse dc balance control to center the range of the STEP ATTEN DC BAL FINE control. This is a 40-turn control with no mechanical stops for the drive shaft.

STEP ATTEN DC BAL FINE—A vernier control for dc balancing the amplifier. With no signals applied to the input connectors, the control is adjusted so there is no trace shift as the VOLTS/CM switch is moved from the 10 mVOLTS position to the 10 μ VOLTS position.

DC OFFSET (ON-OFF switch) Three controls that provide true differential offset of ± 300 mV to the input stage in the 10 μ VOLTS to 10 mVOLTS positions of the VOLTS/CM switch. Effective range for offsetting input signals is higher for the remaining VOLTS/CM switch positions as the decade input attenuators are switched in.

DC OFFSET control and FINE control

DC OFFSET ON-OFF—Two-position toggle switch that turns the DC OFFSET (Coarse) and FINE controls on or off.

DC OFFSET (Coarse)—A coarse control (charcoal knob) for adjusting the dc offset voltage.

Operating Instructions—Type 1A7

	DC OFFSET FINE—A vernier control (red knob) for adjusting the dc offset voltage.
SIGNAL OUTPUT	Signal output connector. Provides a dc-coupled output signal at about 34 mV per displayed cm.
Securing Rod	Gray knob, located near bottom center of the front panel, holds unit securely in the plug-in compartment.

OPERATING INSTRUCTIONS

First-Time Operation

Steps 1 through 5 in the following procedure are intended to help you get the trace on the screen quickly and prepare the unit for immediate use. Step 5 is also a check on the STEP ATTEN BAL DC COARSE and FINE adjustments. Steps 6 through 9 are used to check the GAIN adjustment and these steps along with the remaining steps are intended to acquaint you with some of the basic functions of the Type 1A7.

NOTE

To provide the best possible turn-on conditions for the unit, set the oscilloscope power switch to off before inserting the Type 1A7 into the plug-in compartment. Thus, circuit protection provided by the oscilloscope time-delay relay will be fully utilized.

1. Insert the unit into the oscilloscope plug-in compartment. Tighten the securing rod.

2. Set the Type 1A7 front-panel controls as follows:

VOLTS/CM	10 mVOLTS
VARIABLE	CALIBRATED
POSITION	Midrange
HIGH FREQ 3 dB POINT	500 kHz
LOW FREQ 3 dB POINT	DC
AC-GND-DC (+INPUT)	GND
AC-GND-DC (-INPUT)	GND
STEP ATTEN DC BAL FINE	Midrange
DC OFFSET ON-OFF	OFF

3. Turn the oscilloscope Intensity control fully counter-clockwise and turn on the oscilloscope power. Preset the time-base and triggering controls for a 0.5-ms/cm sweep rate and automatic triggering.

4. Wait about five minutes for the oscilloscope and Type 1A7 to warm up.

NOTE

About five minutes is sufficient time for warm up when using the Type 1A7 for short-term dc measurements. For long-term dc measurements using the higher sensitivities, allow at least 30 minutes warm-up time.

5. Turn up the Intensity control for normal viewing of the trace. The trace should appear within ± 1 cm of graticule center as a rough check on the STEP ATTEN DC BAL COARSE adjustment. To check further, set trace to graticule center with the POSITION control, set the VOLTS/CM switch to 100 μ VOLTS and then reposition the trace to center using the STEP ATTEN DC BAL FINE control. If the trace can be centered, go to step 6. If the trace cannot be positioned to graticule center as described, refer to the Operational Adjustments topic on page 2-3 which describes how to properly adjust these controls.

6. Set the VOLTS/CM switch to 10 mVOLTS.

7. Using the POSITION control, position the trace 3 cm below graticule center.

NOTE

This procedure assumes the oscilloscope has a 6-cm high crt viewing area. If the viewing area is less, adapt the procedure accordingly. For example, position the trace one cm below graticule center and use a 20-mV signal in the next step.

8. Apply a 50-mV peak-to-peak calibrator signal through a coaxial cable to the +INPUT connector on the Type 1A7. Fig. 2-2 illustrates this type of setup.

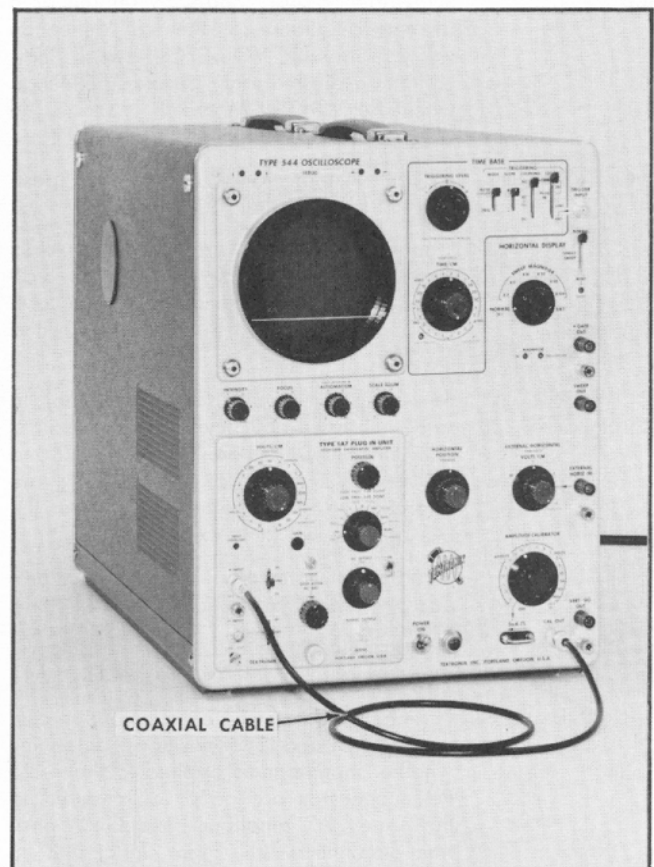

Fig. 2-2. Setup at completion of step 8 in the First-Time Operation procedure.

9. Set the +INPUT AC-GND-DC coupling switch to DC. The display should be square waves which are 5 cm in amplitude (see Fig. 2-3). This is an example of dc-coupled single-ended operation. The calibrator waveform is positive-going 50 mV from the reference established in step 7.

NOTE

If the display is not exactly 5 cm in amplitude, refer to the Operational Adjustments topic on this page for proper GAIN adjustment procedure.

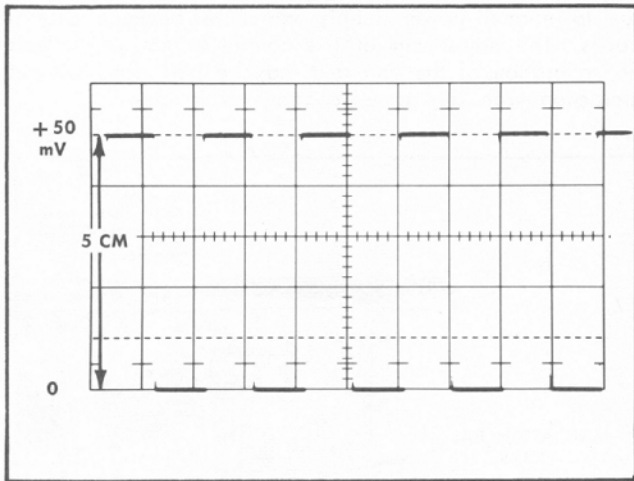

Fig. 2-3. Displaying a 50-mv 1-kHz calibrator signal. Vertical deflection factor: 10 mV/cm; sweep rate: 0.5 msec/cm.

10. Using the POSITION control, position the display so the bottom of the square waves coincide with graticule center.

11. Set the +INPUT AC-GND-DC coupling switch to AC and note that the display shifts downward about 2.5 cm to its average level. This is an example of ac-coupled single-ended input operation.

12. Connect a BNC T connector to the -INPUT connector. Disconnect the coaxial cable from the +INPUT connector and connect it to the T connector. Connect a short coaxial cable from the T connector to the +INPUT connector. Fig. 2-4 shows the setup.

13. Set the -INPUT AC-GND-DC coupling switch to AC. Now the calibrator signal is applied to both inputs as a common-mode signal. A trace (but no waveform) will be displayed because the common-mode signal is rejected by the Type 1A7. This is an example of ac-coupled differential mode of operation.

14. This ends the basic operating procedure for the Type 1A7. Operation of controls not used here, or operation which needs further explanation, will be discussed under General Operating Information.

Operational Adjustments

After the unit has warmed up for at least 30 minutes and stabilized, check its operation to see if adjustment of

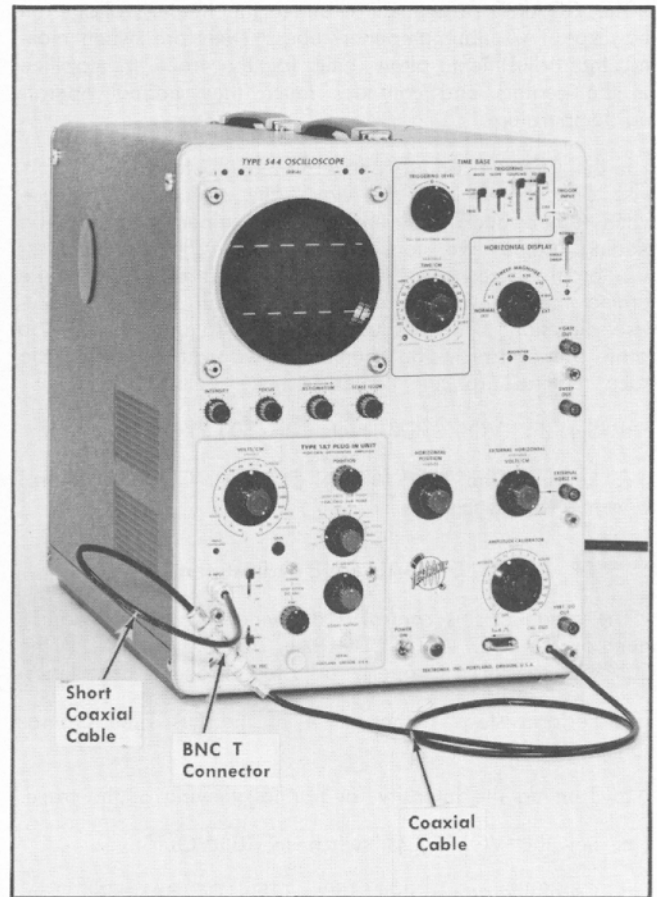

Fig. 2-4. Setup at completion of step 12 in the First-Time Operation procedure.

one or more of the following controls is necessary. Be sure that the vertical amplifier of the oscilloscope used in conjunction with the Type 1A7 is correctly balanced and calibrated (refer to oscilloscope instruction manual), and that the calibrator output voltage is correct.

In the STEP ATTEN DC BAL COARSE and STEP ATTEN DC BAL FINE adjustment procedures that follow, the procedures assume that the Type 1A7 is being used for the first time. Once the STEP ATTEN DC BAL COARSE control is properly adjusted, the only adjustment that needs to be made occasionally is the STEP ATTEN DC BAL FINE adjustment.

1. STEP ATTEN DC BAL COARSE Adjustment

a. Perform steps 1 through 5 in the First-Time Operation procedure if you have not already done so.

b. Return the following controls to these positions:

VOLTS/CM	10 mVOLTS
POSITION	Midrange
STEP ATTEN DC BAL FINE	Midrange

c. Adjust the STEP ATTEN DC BAL COARSE control to return the trace to graticule center.

Operating Instructions—Type 1A7

The COARSE adjustment changes the heater voltage on the Type 1A7 input amplifier tubes. Therefore, when making the adjustment, allow time for the trace to stabilize as the heaters and cathodes reach their normal operating temperature.

If the COARSE adjustment is turned too far in the clockwise direction, it may not have any effect on the trace when turned back again because the wiper arm could be binding against the stop. If this happens, put slight pressure on the screwdriver to hold the shaft depressed while turning the screwdriver about one turn in a counterclockwise direction. Then, reduce the pressure and continue to rotate the control in the counterclockwise direction until the trace reaches graticule center.

- d. Set the VOLTS/CM switch to 500 μ VOLTS.
- e. Readjust the STEP ATTEN DC BAL COARSE control to center the trace.

2. STEP ATTEN DC BAL FINE Adjustment

The range of this control is dependent on proper adjustment of the STEP ATTEN DC BAL COARSE control. If the COARSE control is properly adjusted, proceed as follows:

- a. Perform steps 1 through 4 of the First-Time Operation procedure.
- b. Turn up the Intensity for normal viewing of the trace.
- c. Set the VOLTS/CM switch to 10 μ VOLTS.
- d. Carefully adjust the STEP ATTEN DC BAL FINE control so the trace is positioned to graticule center.

NOTE

During normal operation of the Type 1A7 and with no signal applied (AC-GND-DC switches set to GND), any trace shift that occurs as the VOLTS/CM switch is carefully rotated from 10 mVOLTS to 10 μ VOLTS can be minimized by adjusting the STEP ATTEN DC BAL FINE control. Or, if desired, the POSITION control can be set to midrange and the STEP ATTEN DC BAL FINE control can be used as a positioning control to center the display when using the higher sensitivities (10 μ VOLTS to 100 μ VOLTS) and only if the LOW FREQ 3 dB POINT switch is set to DC.

3. GAIN Adjustment

- a. Perform steps 1 through 9 in the First-Time Operation Procedure.
- b. Adjust the GAIN control so the display is exactly 5 cm in amplitude (see Fig. 2-3). (If 20 mV is applied to the Type 1A7 as mentioned in Step 7 of the First-Time Operation procedure, then adjust the GAIN control so the display is exactly 2 cm in amplitude.)

NOTE

Accuracy of this adjustment is dependent on the voltage accuracy of the calibration source.

4. AC ATTEN BAL Internal Adjustment—AC Stabilization.

When the LOW FREQ 3 dB POINT switch is used to limit the low frequency response of the Type 1A7, the unit automatically employs ac stabilization. This means that when the switch is set to any position except DC, the STEP ATTEN DC BAL and DC OFFSET controls become inoperative and the dc drift in the amplifier is greatly reduced.

Trace centering is then controlled with an internal adjustment, AC ATTEN BAL (see Fig. 2-5). When transferring the Type 1A7 from one oscilloscope to another, it may be necessary to perform a minor readjustment of this control due to normal power supply variations between oscilloscopes. The adjustment of this control in no way affects the calibration of the unit and may be performed without interaction with any other controls as follows:

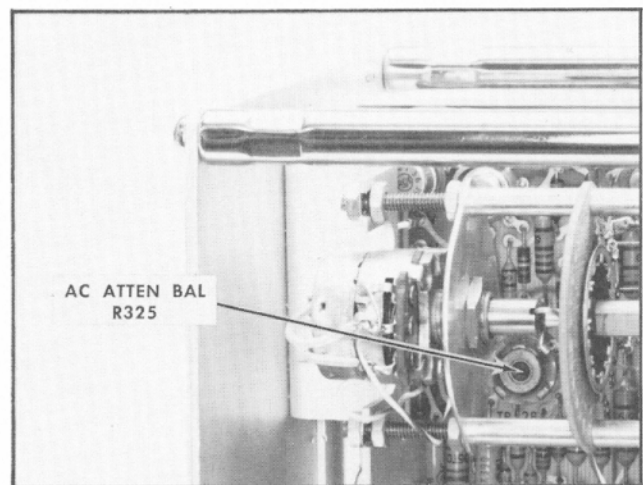

Fig. 2-5. Location of the AC ATTEN BAL adjustment.

- a. Set the Type 1A7 controls to these positions:

VOLTS/CM	10 mVOLTS
AC-GND-DC (+INPUT and -INPUT)	GND
LOW FREQ 3 dB POINT	10 kHz
HIGH FREQ 3 dB POINT	100 Hz
DC OFFSET ON-OFF	OFF

- b. Using the POSITION control, position the trace to graticule center.
- c. Set the VOLTS/CM switch to 10 μ VOLTS.
- d. Adjust the AC ATTEN BAL control R325 to obtain a centered trace.

GENERAL OPERATING INFORMATION

Trace Drift

Although the maximum sensitivity of the Type 1A7 is 10 μ V/cm direct coupled, this does not imply that trace drift at

10 μ V/cm will be comparable to other plug-in units at 50 mV/cm. The Type 1A7 uses all advanced techniques and components available to reduce drift in vacuum tube amplifiers, but is still limited by the inherent problems remaining in these devices.

Under ideal conditions (fully warmed-up unit, no mechanical shocks, constant thermal environment, and side panels installed on oscilloscope), the trace should remain within 3 cm ($\pm 30 \mu$ V) of graticule center at 10 μ V/cm dc-coupled for a period of at least 30 seconds.

To obtain accurate dc measurements at maximum sensitivity it is necessary to ground the input and dc balance the amplifier just before making the measurement. This is accomplished by adjusting the STEP ATTEN DC BAL FINE control as described on page 2-1. Always rotate the switches carefully when using the Type 1A7 at the higher sensitivities to minimize mechanical shock.

When making dc measurements at test points where the source impedance is high, the grid current of the Type 1A7 should be checked before the measurement. Steps 6 and 7 in the Calibration Procedure describe how to check and adjust, if necessary, the internal +GRID CURRENT and -GRID CURRENT controls to offset the trace shift due to grid current.

Input Capacitor Coupling

In order to preserve the low noise performance designed into the Type 1A7, avoid overdriving the input stage. When the stage is overdriven, the trace is deflected violently off the screen and the input stage will draw grid current. To prevent this from happening when measuring dc voltages, use a higher deflection factor (lower sensitivity) when first connecting the Type 1A7 to an unknown voltage source. Then, if the deflection is too small to make the measurement, switch to a lower deflection factor.

For signals having both ac and dc components where you intend to measure only the ac component, take advantage of the pre-charging circuit incorporated in the unit. This circuit permits the 0.1- μ F coupling capacitor to charge to the dc source voltage when the AC-GND-DC input coupling switch is set to GND. The procedure for using this circuit is as follows:

1. Before connecting the Type 1A7 to a signal containing a dc component, set the AC-GND-DC input coupling switch to GND. Then connect the input to the circuit under test.
2. Wait about one second for the coupling capacitor to charge.
3. Set the input coupling switch to AC. The trace (display) will remain on the screen and the ac component can be measured in the usual manner.

Signal Input Connections

When connecting signals to the +INPUT and -INPUT connectors on the Type 1A7, consider the method of coupling that will be used. Table 2-1 lists a choice of six different methods. For each method the table lists the advantages, limitations, accessories required, source loading and precautions to consider. Check through the table and select the method which is suitable for your particular application.

Using Method 1, ordinary unshielded test leads can sometimes be used to connect the Type 1A7 to a signal source, particularly when a high-level, low-frequency signal is monitored at a low-impedance point. However, when any of these factors is missing, it becomes increasingly important to use shielded signal cables using Methods 2 and 3. In all cases, the signal-transporting leads should be kept as short as practical.

When making single-ended input measurements (conventional amplifier operation), be sure to establish a common-ground connection between the device under test and the Type 1A7. The shield of a coaxial cable is normally used for this purpose.

Differential measurements require no common-ground connection¹, and therefore are less susceptible to interference by ground-loop currents. Some problems with stray magnetic coupling into the signal-transporting leads can also be minimized by using a differential rather than a single-ended measurement. These considerations are discussed later in this section under Differential Operation.

It is always important to consider the signal-source loading and resulting change in the source operating characteristics due to the signal-transporting leads and the input circuit of the Type 1A7. The circuit at the input connectors can normally be represented by a 1-megohm resistance to ground paralleled by 47 pF. A few feet of shielded cable may increase the parallel capacitance to 80 pF or more. In many cases, the effects of these resistive and capacitive loads may be too great and it may be desirable to minimize them through the use of an attenuator probe.

Attenuator probes not only decrease the resistive and capacitive loading of a signal source, but also extend the measurement range of the Type 1A7 to include substantially higher voltages. Passive attenuator probes having attenuation factors of 10 \times , 100 \times and 1000 \times , as well as other special-purpose types are available through your Tektronix Field Engineer or Field Office.

Some measurement situations require a high-resistance input to the Type 1A7 with very little source loading or signal attenuation. In such a situation a passive attenuation probe cannot be used. However, this problem may be solved by using a cathode-follower probe such as the P500CF or using the floating input provision of the Type 1A7.

The floating input provision applies only to dc-coupled signals which permit the use of 10 mVOLTS through 10 μ VOLTS positions of the VOLTS/CM switch. Since no input attenuator is used at these switch positions, the internal grid-return resistor alone establishes the 1-megohm input resistance. This resistor in each input can be disconnected by removing a wire strap from the attenuator etched wiring board (see Fig. 2-6). The signal source must then provide a dc path for the tube grid current.

The grid current is typically less than 4 nanoamperes, but may be several times higher depending upon the parameters of the individual tube. The signal-source impedance is therefore an important factor since grid current will pro-

¹However, the dc plus peak ac voltages on the test points with respect to the chassis potential of the Type 1A7 should be limited to the levels listed in Section 1 under Maximum Common-mode Input Voltage characteristics, Table 1-6. Higher levels will degrade the common-mode rejection ratio and exceed the input voltage rating of the unit.

TABLE 2-1
SIGNAL COUPLING METHODS

Method of Coupling the Signal	Advantages	Limitations	Accessories Required	Source Loading	Precautions
1. Open (unshielded) test leads.	Simplicity.	Subject to stray pickup.	BNC to banana jack adapter (103-0033-00). Two test leads.	1 MΩ and 47 pF at input, plus test leads and adapter.	Use short leads. Position leads for minimum stray pickup.
2. 1×, 1 MΩ Probe.	Full sensitivity. Total Type 1A7 / Oscilloscope bandwidth.	High capacitance of cable.	P6028 is 1× equipped with BNC connector.	1 MΩ and ≈87 pF.	High capacitance loading.
3. Underterminated coax cable.	Full sensitivity.	High capacitance of cable.	Coax cable with BNC connector(s).	1 MΩ and 47 pF plus cable capacitance.	High capacitance loading.
4. 10×, 8 MΩ Probe for P6023; 10 MΩ for others.	Reduced resistive and capacitive loading, full Type 1A7 / Oscilloscope bandwidth. Retain high CMRR by using two P6023 Probes for differential operation.	10× attenuation.	P6006, P6008 and P6023 are 10×.	P6006: ≈7 pF, 10 MΩ. P6008: ≈7.5 pF, 10 MΩ. P6023: ≈12 pF, 10 MΩ.	Check probe frequency compensation. Use square-wave frequency less than 5 kHz preferably 1 kHz.
100×, 10 MΩ Probe.		100× attenuation.	P6007: 100×.	P6007: ≈2 pF, 10 MΩ.	
1000×, 100 MΩ Probe.		1000× attenuation.	P6015: 1000×.	P6015: ≈2.7 pF, 100 MΩ.	
5. Current transformer CT-2 and P6041 Probe. Terminated in 50 Ω at Type 1A7. Bandwidth that of Type 1A7/Oscilloscope.	Current transformer can be permanent part of test circuit. Less than 2.2 pF to test circuit chassis. Measure signal currents in transistor circuits. Pulse current rating: 100 amps peak.	Low frequency Limit: ≈ 1.2 kHz. Rms current rating: 2.5 amps. Deflection factor: 1 mV/mA.	Nothing extra (Perhaps additional coax cable for either transformer).	Insertion Z: 0.04 Ω paralleled by about 5 μH. Up to 2.2 pF.	Not a quick-connect device.
6. P6016 AC Current Probe and Type 131 Amplifier. Bandwidth that of Type 1A7/Oscilloscope.	Measure signal currents. AC current saturation rating: 15 amps peak to peak.	Low frequency Limit: ≈ 50 Hz. Basic deflection factor: 50 mV/mA.	None	Insertion Z with step function applied: 0.04 Ω after 0.1 μs.	To preserve low-frequency response avoid scratching probe current transformer core.

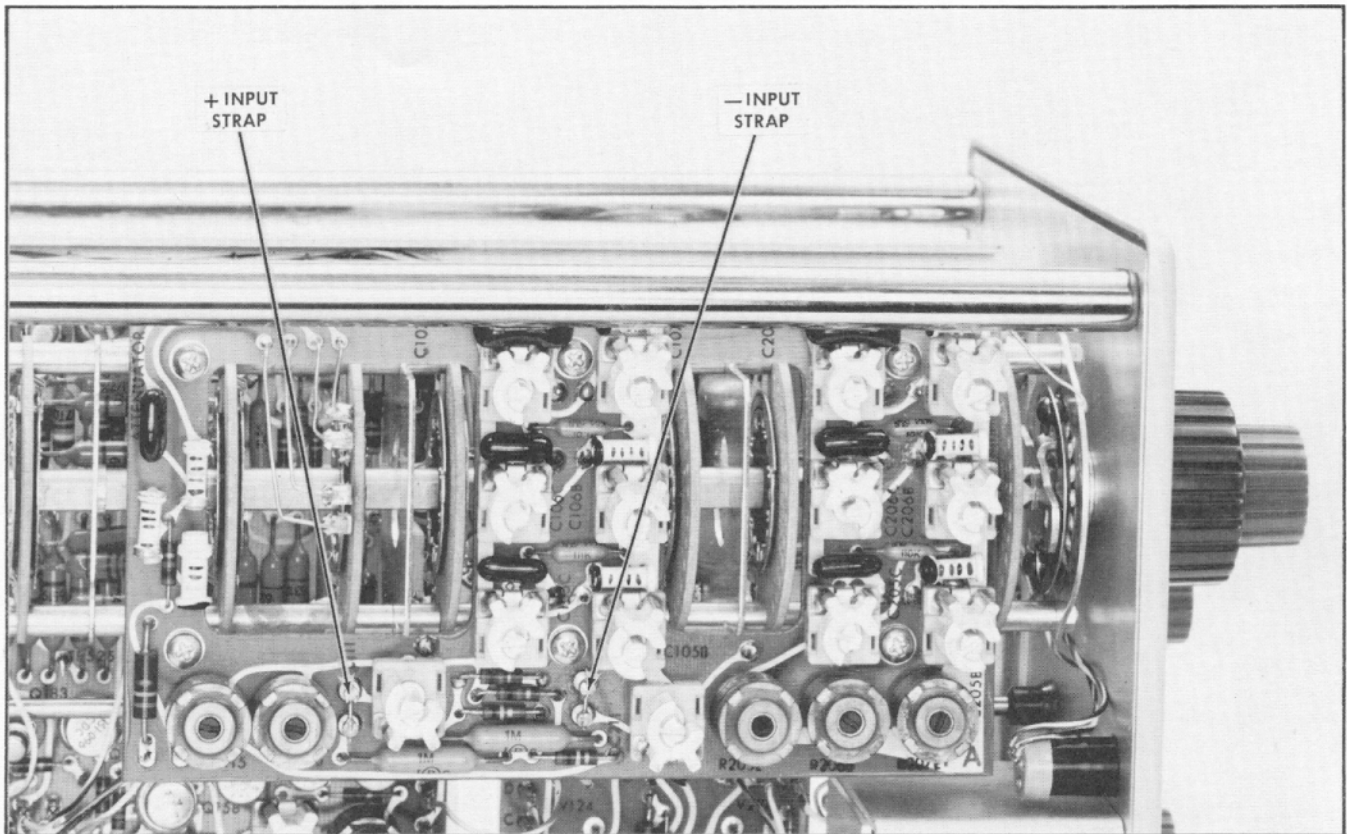

Fig. 2-6. Location of removable wire straps for floating input provision.

duce a dc offset. For example, a 4-nanoampere grid current through 10 megohms produces a 40-mV offset; this may result in a significant error where small signal voltages are of concern.

IMPORTANT

When the wire straps are removed from the attenuator etched wiring board, the +GRID CURRENT and -GRID CURRENT internal adjustments are disconnected.

The high-frequency response will also depend upon the signal-source impedance, since various shunt capacitances between the source and the input grid must charge and discharge through that impedance.

The grid-return strap in each input must be connected when a VOLTS/CM switch position other than those mentioned previously is used so that the attenuation factor of the input attenuators will be correct.

Display Polarity

Single-ended signals can be applied to either the +INPUT or -INPUT connector. If the +INPUT is chosen, positive-going changes in the input signal will cause the trace to be deflected upward, and negative-going changes will cause it to be deflected downward. If the -INPUT is chosen, input-to-display polarity relationship will be reversed as shown previously in Fig. 2-1.

A similar polarity relationship exists for differentially applied signals, but pertains to the direction of voltage change at one input with respect to the other rather than with respect to chassis potential.

Deflection Factor

The amount of trace deflection produced by a signal is determined by the signal amplitude, the attenuation factor (if any) of a probe, the setting of the VOLTS/CM switch and the setting of the VARIABLE control. The calibrated deflection factors indicated by the VOLTS/CM switch apply only when the VARIABLE control is set fully clockwise into the switch detent CALIBRATED position.

The range of the VARIABLE control is at least 2.5:1 and provides uncalibrated deflection factors covering the full range between the fixed settings of the VOLTS/CM switch. The control can be set to extend the deflection factor to at least 25 volts/cm.

Voltage Comparison Measurements

Some applications require a set of deflection factors other than the fixed values provided by the VOLTS/CM switch. One such application is comparison of signal amplitudes by ratio rather than by absolute voltage. To accomplish this, apply a reference signal to either input of the Type 1A7.

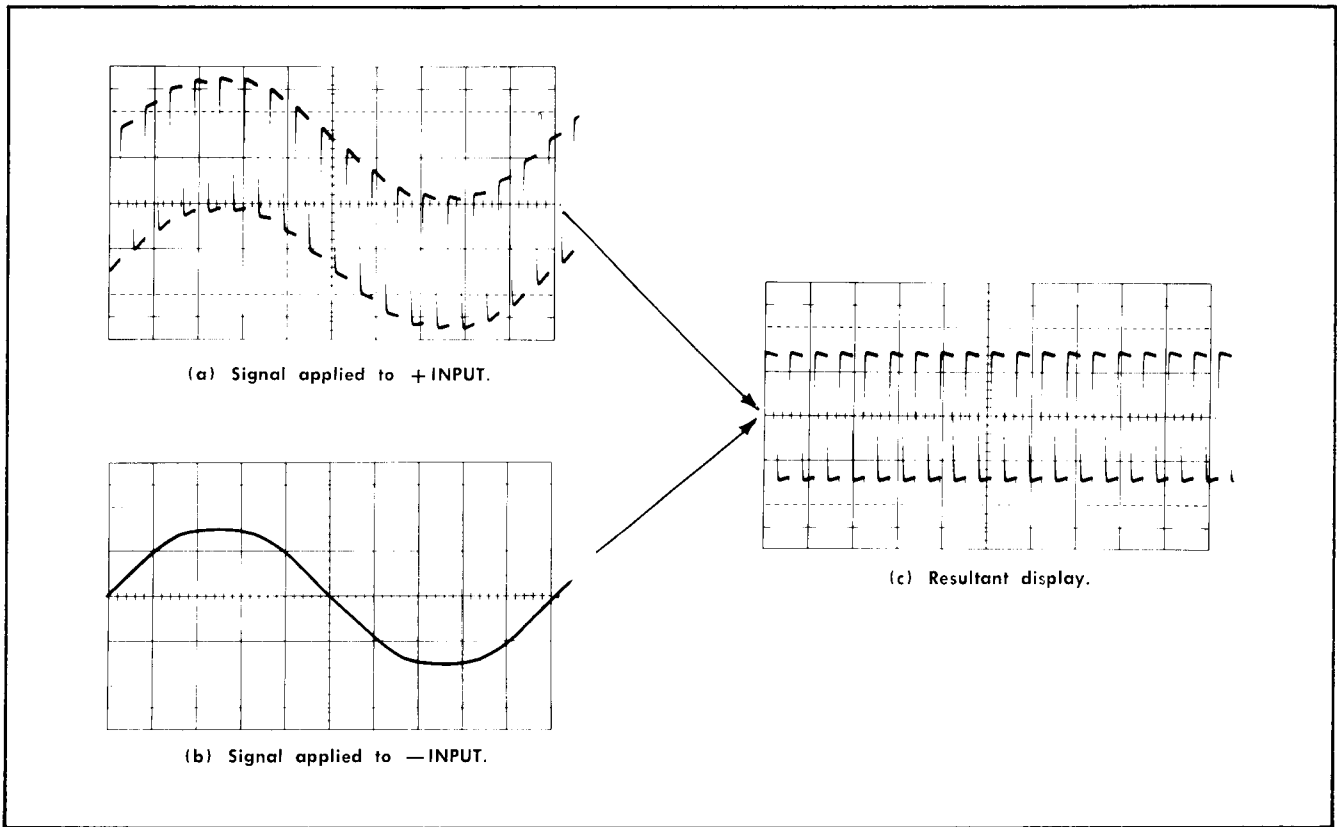

Fig. 2-7. Waveforms showing differential rejection of a common-mode signal. Resultant waveform (c) shows the difference between the two signals.

Set the VOLTS/CM switch and VARIABLE control so that the reference display covers the desired number of graticule divisions. Do not change this setting of the VARIABLE control throughout the subsequent comparisons. The setting of the VOLTS/CM switch can be changed, however, to accommodate large ratios. In doing so, regard the numbers which designate the switch position as ratio factors rather than voltages.

NOTE

If a known reference voltage is used to set up a deflection factor larger than $100 \mu\text{V}/\text{cm}$, and then smaller ratios are used for the voltage comparison measurements (VOLTS/CM switch set to positions from $50 \mu\text{VOLTS}$ to $10 \mu\text{VOLTS}$), measurement tracking accuracy decreases slightly unless the VARIABLE control is set near the CALIBRATED position. For utmost measurement accuracy, use a smaller known reference voltage to calibrate $10 \mu\text{V}/\text{cm}$, $20 \mu\text{V}/\text{cm}$ and $50 \mu\text{V}/\text{cm}$.

Differential Operation

Differential voltage measurements are made by applying the signals to the +INPUT and -INPUT connectors. Then, both AC-GND-DC switches should be set to the same position: AC or DC, depending on the method of signal coupling desired. When using the Type 1A7 for differential

operation, only the voltage difference between the two signals is amplified and displayed on the crt. Common-mode signals (signals that are common in amplitude, frequency and phase) are rejected and not displayed (see Fig. 2-7).

The Type 1A7 differential input provision may be used to eliminate interfering signals such as ac line-frequency hum. Single-ended measurements sometimes yield unsatisfactory information because of hum resulting from ground-loop currents between the oscilloscope and the device under test. In other cases, it may be desirable to eliminate a dc voltage by means other than the use of a dc-blocking capacitor which would limit low-frequency response.

These limitations of single-ended measurements are virtually eliminated in differential measurements. A differential measurement is made by connecting each of the two inputs to selected points in the test circuit. Since the chassis of the Type 1A7 need not be connected in any way to the test circuit, there are few limitations to the selection of these test points.

The ability of the Type 1A7 to reject common-mode signals is indicated by the "common-mode rejection ratio" (CMRR). This ratio is at least 50,000:1 at the input connectors for the higher sensitivities when signals dc to 100 kHz are dc-coupled to the inputs. To show the significance of this characteristic, assume that a single-ended input signal consists of an unwanted 60-Hz hum at 1 volt peak to peak modulated by a desired signal at 1 mV peak to peak. If an attempt is made

to display the desired signal with the VOLTS/CM switch set to 200 μ VOLTS, the 60-Hz hum would produce a deflection equivalent to 5000 cm and thus no useful information about the 1-mV signal could be obtained.

If the same 1-mV signal is monitored differentially so that the 60-Hz hum signal is common mode at the inputs, no greater than one part in 50,000 of the common-mode signal would appear in the display. Thus, the desired signal would produce a display amplitude of 5 cm ($1 \text{ mV} \div 200 \mu\text{V/cm} = 5 \text{ cm}$) with no more than 0.1 cm ($1 \text{ V} \div 50,000 = 20 \mu\text{V}$; $20 \mu\text{V} \div 200 \mu\text{V/cm} = 0.1 \text{ cm}$) of interference due to the common-mode signal.

There are a number of factors which can degrade the common-mode rejection ratio of the Type 1A7. The principal requirement for maximum rejection is for a common-mode signal to arrive at the grids of the two input tubes in precisely the same form. For example, a difference of only 0.01% in the attenuation factors of the two input attenuators may reduce the rejection ratio to 10,000:1. Likewise, any difference between the source impedances at the two points in the device under test will degrade the rejection ratio. Another factor is that ordinary attenuator probes may reduce the rejection ratio to 100:1 or less. However, P6023 Probes have adjustable R and C attenuation factors which permit them to be used with minimum reduction in the common-mode rejection ratio.

Outside influences such as magnetic fields can also degrade the performance, particularly when low-level signals are involved. This type of interference can be minimized by using the same type of signal-transporting lead for each input. Moreover, where an interfering magnetic field cannot be avoided, the two leads should be equally exposed to the field, if possible, by taping or twisting them together throughout most of their length. Low-frequency measurements can be similarly protected by using a shielded cable which contains a twisted pair of conductors.

Differential amplifier operation is also useful for monitoring push-pull signals regardless of whether interfering signals are present or not.

P6023 Probes

The following adjustment procedure is recommended when preparing to use P6023 Probes for differential measurements:

1. Connect one probe for dc-coupled single-ended input operation. Obtain a triggered display of an appropriate square-wave signal such as that from the oscilloscope amplitude calibrator. Adjust the probe Dc Atten Calibration control for correct deflection sensitivity; then use the AC Coarse Comp and Ac Comp Fine Adjust control to compensate the probe for proper square-wave response.

2. Connect a second probe for dc-coupled operation. Apply the square-wave signal to both probes at 100 volts peak to peak. Obtain a free-running sweep and adjust the Dc Atten Calibration control of the second probe for maximum low-frequency cancellation. This is indicated by elimination of the two-trace appearance, resulting in one trace of minimum thickness.

3. Adjust the Ac Coarse Comp and Ac Comp Fine Adjust controls of the second probe to minimize the amplitude of the differentiated pulses on the trace.

4. The probes are now matched and ready for use at any sensitivity which employs the particular input attenuator used during steps 2 and 3. Whenever it is necessary to use a different input attenuator, steps 2 and 3 should be repeated for that attenuator. The input sensitivity group associated with each of the four attenuators is listed in Table 2-2.

TABLE 2-2

VOLTS/CM Switch Position	Input Attenuator
10 μ VOLTS to 10 mVOLTS	1 \times
20 mVOLTS to .1 VOLTS	10 \times
.2 VOLTS to 1 VOLTS	100 \times
2 VOLTS to 10 VOLTS	1000 \times

Bandwidth Selection

In addition to the differential rejection of unwanted signals, many times an undesired signal can be attenuated by varying the bandwidth of the unit. The concentric LOW FREQ 3 dB POINT and HIGH FREQ 3 dB POINT switches on the front panel of the Type 1A7 control the low frequency and high frequency 3-dB down points of the amplifier. The LOW FREQ 3 dB POINT switch provides low-frequency cutoff of flat to dc or approximate 3-dB down points at 0.1, 1, 10, 100, 1 kHz and 10,000 Hz. The HIGH FREQ 3 dB POINT switch controls the high-frequency rolloff from 500 kHz down to 100 Hz in a 1-3-1 sequence. Beyond the 3 dB point, frequency response falls off at 6 dB/octave. Between 100 μ V/cm and 10 μ V/cm the maximum frequency response changes slightly from 500 kHz.

Varying the bandwidth of the Type 1A7 is useful, for example when displaying a low-frequency sinusoidal waveform in the presence of high-frequency noise. By reducing the high-frequency response the noise can, in many cases, be almost completely eliminated without distorting the desired signal (see Fig. 2-8). Likewise, undesired low-frequency hum can be filtered out by restricting the low-frequency response of the unit. When using the LOW FREQ 3 dB POINT and HIGH FREQ 3 dB POINT switches, be careful not to distort non-sinusoidal waveforms by overly restricting the amplifier's bandwidth.

Dc Offset Operation

By using the DC OFFSET controls, it is possible to use the Type 1A7 for dc-coupled differential amplifier operation to observe small signals whose dc potential difference may be considerable. The offset is $\pm 300 \text{ mV}$ when using a dc deflection factor of 10 μ V/cm to 10 mV/cm (see Table 2-3).

In the 20 mVOLTS, 50 mVOLTS and .1 VOLTS positions of the VOLTS/CM switch, the $\pm 300\text{-mV}$ offset is effectively multiplied by the input attenuator to a range of $\pm 3 \text{ V}$. Table 2-3 summarizes the effective dc offset voltages internally available for all the VOLTS/CM switch positions. The table also lists the input attenuator that is switched into the amplifier circuit for the various VOLTS/CM switch positions.

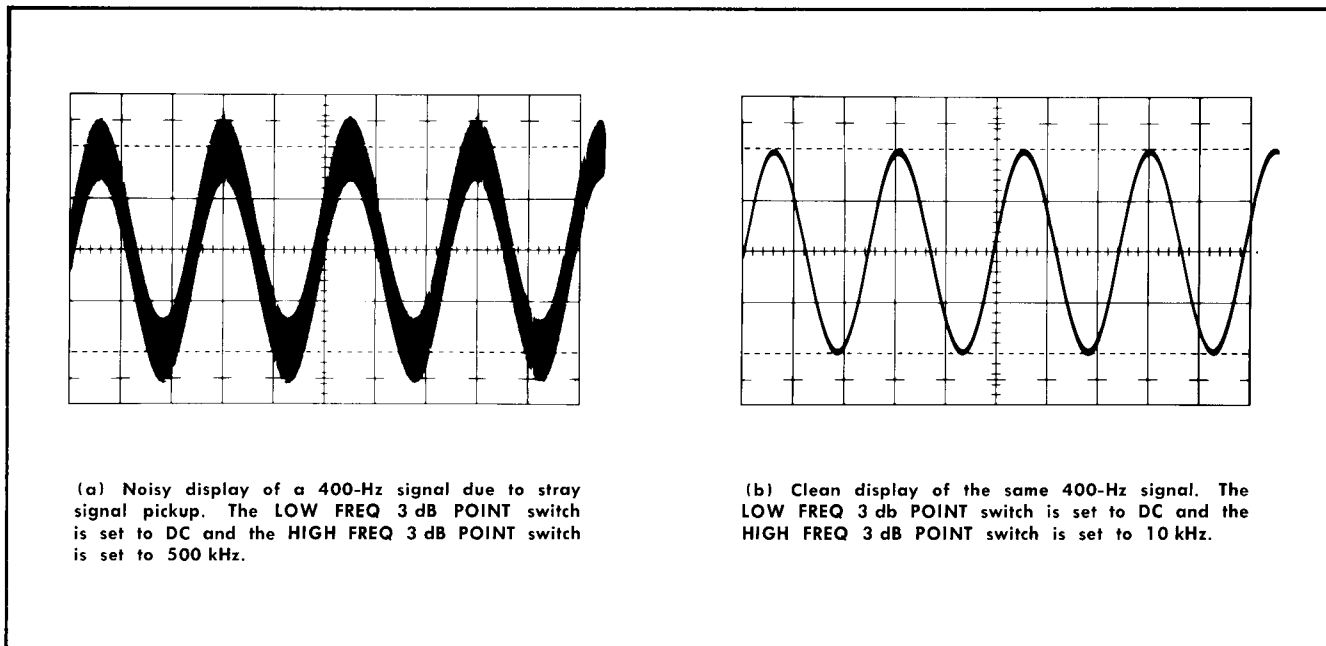

Fig. 2-8. Improving the signal-to-noise ratio by controlling the bandwidth of the Type 1A7.

TABLE 2-3

VOLTS/CM Switch Positions	Input Attenuator Switched In	Effective Offset Voltage Range
10 μ VOLTS to 10 mVOLTS	1X	± 300 mV
20 mVOLTS to .1 VOLTS	10X	± 3 V
.2 VOLTS to 1 VOLTS	100X	± 30 V
2 VOLTS to 10 VOLTS	1000X	± 300 V

The DC OFFSET controls can also be used in dc-coupled single-ended input operation. A low-frequency ac signal super-imposed on dc, for example, can be observed by offsetting the dc potential so the ac signal can be displayed.

INPUT OVERLOAD Light

At the higher sensitivities the INPUT OVERLOAD light turns on whenever a dc differential signal greater than about 0.23 volt is applied to the input. Never leave the Type 1A7 connected to a circuit if this light is on, as this may mean that a damaging voltage is present. Table 2-4 lists the approximate dc voltage that will turn on the light.

TABLE 2-4

VOLTS/CM Switch Position	Approx. Turn-on-DC Voltage for INPUT OVERLOAD Light
10 μ VOLTS to 10 mVOLTS	0.23 V
20 mVOLTS to .1 VOLTS	2.3 V
.2 VOLTS to 1 VOLTS	23 V
2 VOLTS to 10 VOLTS	230 V

The neon INPUT OVERLOAD light serves another important function. Since most sensitive differential amplifiers of the past have been ac coupled internally, they were incapable of indicating to the operator the presence of a dc differential signal.

Since these amplifiers were usually direct coupled at the input, a dc differential signal could overload the input stage and cause a reduction in gain. The small voltages to be measured would not be distorted, but were reduced in amplitude. As a result, amplitude measurements made under such conditions were not accurate and the operator would not be aware of the inaccuracies. In contrast, the Type 1A7 INPUT OVERLOAD light provides an indication that such a signal is present by lighting before the gain calibration drops by 1%.

If the INPUT OVERLOAD light turns on, there are two options:

1. When the Type 1A7 is in ac stabilization (LOW FREQ 3 dB POINT switch is not set to DC), dc differential signals between 0.23 volt and 0.53 volt may be removed by using the front-panel DC OFFSET controls. Once the INPUT OVERLOAD light is extinguished, gain calibration is restored to within 1%. Direct-coupled operation (AC-GND-DC switch set to DC) is possible for signals with up to 0.3-volt offset at the higher sensitivities. See Table 2-3 which lists the effective offset voltage ranges.

2. Dc differential signals greater than 0.23-volt and up to 600 volts may be removed by using ac coupling at the input (AC-GND-DC switch set to AC). This necessarily limits the low-frequency response to 1.6 Hz or 0.16 Hz with a 10X probe.

If there is any doubt as to the amount of input dc offset voltage present, simply set the VOLTS/CM switch to a larger deflection factor (lower sensitivity) and check that the DC

OFFSET ON-OFF switch is set to OFF. Then, measure the dc offset voltage using normal dc-coupled differential operation.

The INPUT OVERLOAD light is insensitive to common-mode overloads or to frequencies above 3 kHz. In such situations, it is possible to overload the Type 1A7 without lighting the input overload light.

NOTE

It is normal for the INPUT OVERLOAD light to turn on for a few seconds during warm up.

SIGNAL OUTPUT Connector

A dc-coupled vertical signal output, restored to zero volts dc, is provided on the front panel of the Type 1A7. Output signal amplitude is about 34 mV per displayed cm. Two suggested uses for this output are:

1. Differential measurements.
2. Minimum-noise low-level signal work.

Not all true rms voltmeters have a signal output connector for applying a monitoring signal to the oscilloscope. None has a bandwidth control or differential input. To overcome these limitations of ac voltmeters, the following setup is suggested:

1. Instead of connecting the signal from the device under test to the voltmeter, connect the signal to the Type 1A7. Use the oscilloscope to provide a visual display.

2. Connect the voltmeter to the SIGNAL OUTPUT connector.

3. Calibrate the system gain if the voltmeter scales are used to read a simple multiple of the input to the Type 1A7. This can be done by using the Type 1A7 VARIABLE control. The system gain is then in direct proportion to the VOLTS/CM setting at $100 \mu\text{V}/\text{cm}$. At higher sensitivities ($50 \mu\text{V}$, $20 \mu\text{V}$ and $10 \mu\text{V}$), the deflection factor does not track in proportion to the VOLTS/CM switch positions and an additional error of about 10% is possible unless the VARIABLE control is set near the CALIBRATED position. For further information, refer to Voltage Comparison Measurements page 2-7.

SECTION 3

CIRCUIT DESCRIPTION

Introduction

The block diagram description is based primarily on the block diagram located on the fold-out page in Section 9 of this manual. To follow the detailed circuit description, refer to the illustrations provided in this section as well as the schematic diagrams in Section 9.

In general, when following the signal through the stages in the detailed description (particularly as indicated at the input and output of Figs. 3-3, 3-6 and 3-8), the Type 1A7 is set for single-ended operation and a positive-going (+ signal) is applied to the +INPUT connector. Since the amplifier and Emitter Follower stages in the Type 1A7 are the same (symmetrical) for both sides, the + input side is described in more detail.

BLOCK DIAGRAM DESCRIPTION

Signals applied to the +INPUT connector are applied via the AC-GND-DC switch SW101 to the +Input Attenuator. The attenuators for both sides are the conventional RC type with one exception. In the -Input Attenuator the resistive portion of the divider is adjustable so the -input side can be matched to the +input side to obtain optimum dc common-mode signal rejection.

From the +Input Attenuator the signal is applied to the Input Amplifier stage. Special constant-current bootstrap circuits in this stage allow handling of large common mode signals. In differential mode of operation, difference signals are amplified while common-mode signals are suppressed. A dc offset voltage can be inserted in this stage by means of the DC OFFSET ON-OFF switch, FINE and DC OFFSET controls.

Signals from the Input Amplifier are applied to an EF (Emitter Follower) stage. This stage provides a low-impedance drive for the Neon Bulb Driver and Gain-Switching Amplifier stages that follow. The Neon Bulb Driver stage is a non-linear amplifier that operates from the signal voltage in the EF stage. Excessive differential drive to the Type 1A7 input causes the Neon Bulb Driver to turn the INPUT OVERLOAD light on.

In the Gain-Switching Amplifier stage, the gain is controlled by switching different resistors between the collectors to shunt the collector load. In addition, the LOW FREQ 3 dB POINT switch is located in this stage to control the low-frequency 3-dB down point.

Signals from the Gain-Switching Amplifier stage are applied to the Output Amplifier for further amplification. Then the signals are applied via pins 1 and 3 of the interconnecting plug to the input of the oscilloscope vertical amplifier. Located in this stage are the HIGH FREQ 3 dB POINT, VARIABLE (VOLTS/CM) and positioning controls.

A single-ended signal is taken from pin 1 of the interconnecting plug and applied to the Signal Output CF stage. At the output of this stage, the signal is applied to the SIGNAL OUTPUT connector located on the front panel of

the Type 1A7. Output signal is 34 mV for every cm of display on the oscilloscope screen.

There is about 3% variation between oscilloscopes in the regulated +75-volt supply. To minimize readjustment of the COARSE STEP ATTEN DC BAL control each time the Type 1A7 is transferred from one oscilloscope to another, the +75 volts is re-regulated. This is accomplished in the Regulated Heater Power Supply circuit of the Type 1A7. The added stability of this supply also decreases drift of the Type 1A7 Input Amplifier.

DETAILED CIRCUIT DESCRIPTION

Input Amplifier

The +INPUT coupling switch SW101 permits selection of ac or dc signal coupling, or grounding of the amplifier input without grounding the signal source. The GND position provides a ground reference for the unused grid for single-ended input applications. It also permits ac-coupling capacitor C102 to be charged or discharged before the signal is applied to the parallel-connected input grids. To accomplish this, the output end of C102 is grounded and R101 is placed between the +INPUT connector and the input side of C102 (see Fig. 3-1) to limit the charging current. Capacitor C101 is used with R101 so the GND position of the input coupling switch presents the same load to the circuit under test as the AC position.

The VOLTS/CM switch has decade attenuators that range from 1X to 1000X. Several desirable characteristics are provided by these attenuators:

1. The input time constant is established at $47 \mu\text{s}$ ($1 \text{ M}\Omega \times 47 \text{ pF}$) and equalized at all settings of the VOLTS/CM switch for both input connectors. In the +input 1X attenuator position, this is accomplished by adjusting C111 (see Fig. 3-2). Adjustable capacitors C105B, C106B, and C107B (refer to Attenuators diagram) serve the same purpose for the other +input attenuator positions.
2. The resistive (dc or low-frequency) attenuation ratios of the +input and -input attenuators are equalized by adjusting R205E, R206E, and R207E.
3. Attenuator (ac) compensation and equalization of the +input and -input attenuator compensations are obtained by adjusting C105C, C205C, C106C, C206C, C107C and C207C.

Total grid current for tubes V124 and V134 is normally about 3 nanoamperes and this produces a voltage drop of about 3 mV across R112. Under no-signal conditions the +GRID CURRENT control R115 is set to restore the grid voltage to zero in the presence of the R112 voltage drop. As a result, the position of the trace coincides with zero reference on the screen.

For special applications, the strap or wire link connected from the grids of V124-V134 (see Fig. 3-2) to R112 can be removed to provide a substantially higher input resistance

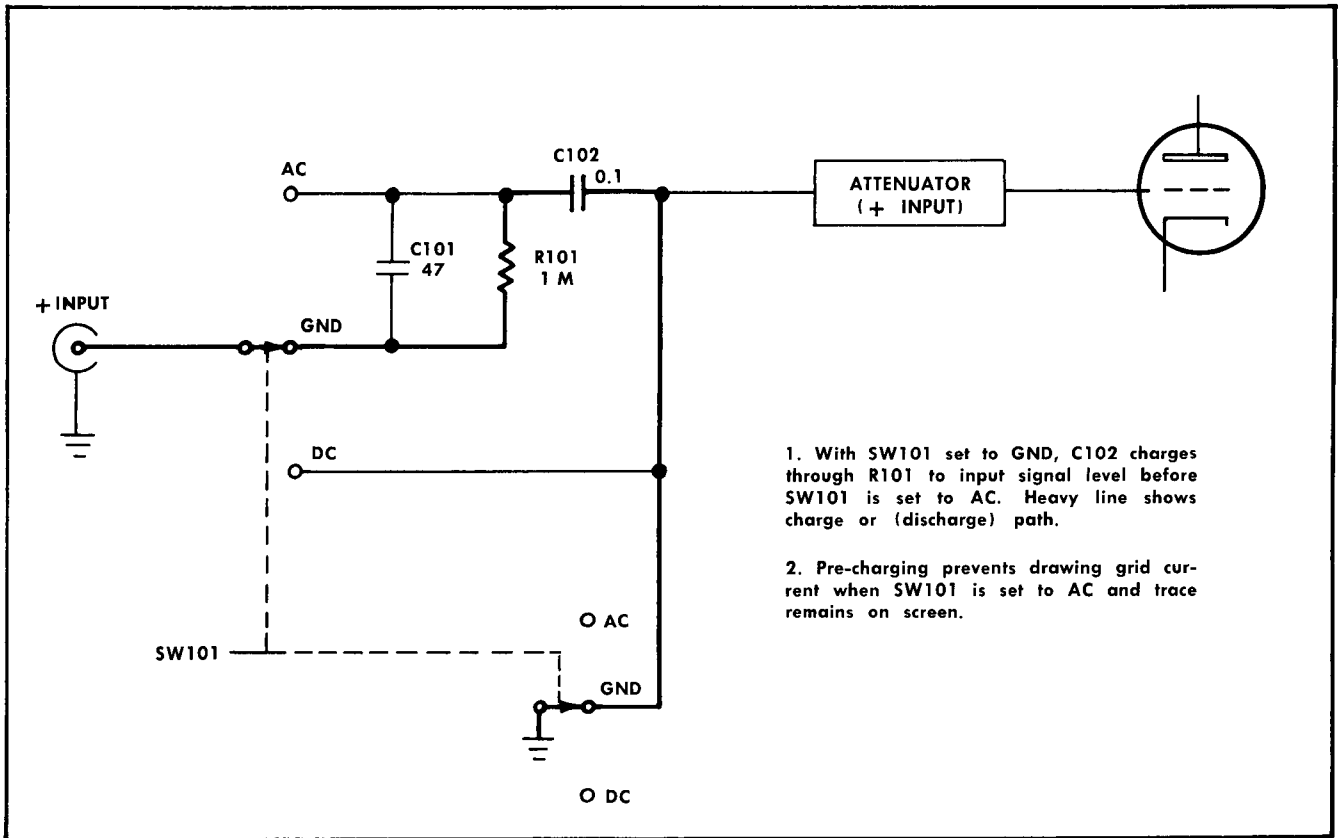

Fig. 3-1. +Input circuit showing C102 charge path. The same path is used when C102 discharges.

than the 1 megohm of R112 when using the $10\ \mu\text{V}/\text{cm}$ to $10\ \text{mV}/\text{cm}$ deflection factors. The strap must be reconnected when the $10\times$, $100\times$, or $1000\times$ attenuators are used so the attenuation ratios will be correct.

Networks L123-R123 and L133-R133 dampen most oscillations that might result when connecting an inductance to the +INPUT connector. At low frequencies L123 and L133 act as a short circuit for the resistors to maintain the low-noise characteristics of the unit. But, at high frequencies where parasitic oscillations are likely to occur, these coils act as an open circuit and the resistors stop the oscillations.

Diode 122 limits V124-V134 grid current during tube warm up.

V124-V134-Q144 form a cascode amplifier for the +input side and V224-V234-Q244 form the cascode amplifier for the -input side (see Fig. 3-3). Together they operate as a cascode paraphase or cascode differential amplifier, depending on whether one or both inputs are used. V124 and V134 are connected in parallel to reduce noise.

Transistor Q154 is a long-tail (high resistance) constant current source for V124-V134; Q254 is the constant current source for V224-V234. With the DC OFFSET ON-OFF switch set to the OFF position, divider resistors R161, R162, R163 and R164 set the Q154-Q254 base voltages. Transistor Q158 is another constant current source but it provides current to both sides simultaneously. These constant current sources tend to keep the voltages and currents the same to

prevent common-mode signals from appearing at the collectors of Q144 and Q244. In addition, they tend to maintain fixed gain and linearity with large signal inputs.

The dynamic range of the amplifier is limited to grid voltage differences between +input and -input of about 300 mV. This limit does not pertain to the grid voltages with respect to chassis potential, but only with respect to one another.

Common-mode signal amplitudes up to ± 10 volts peak with respect to ground (20 V peak to peak) at the grids will produce essentially no change in the division of the common-cathode current between the two sides. The common-cathode voltage will, however, follow the common-mode signal in the manner of a single cathode follower. By means of bootstrapping (see Fig. 3-4), this voltage variation causes an equal variation at the Q144-Q244 bases so the V124-V134 and V224-V234 plate-to-cathode voltages remain essentially constant. Bootstrapping, then, virtually eliminates any change in current division between the two sides due to differences in tube parameters.

Since the impedance of the common-cathode current source is finite, a small but significant change in the total common-cathode current will occur. This additional current probably will not divide between the two sides in the same proportions as the basic current, because of differences in the transconductance of the tubes. The differences between tubes can be corrected by proper setting of the DC COMMON MODE BALANCE control R175 (see Fig. 3-3). This

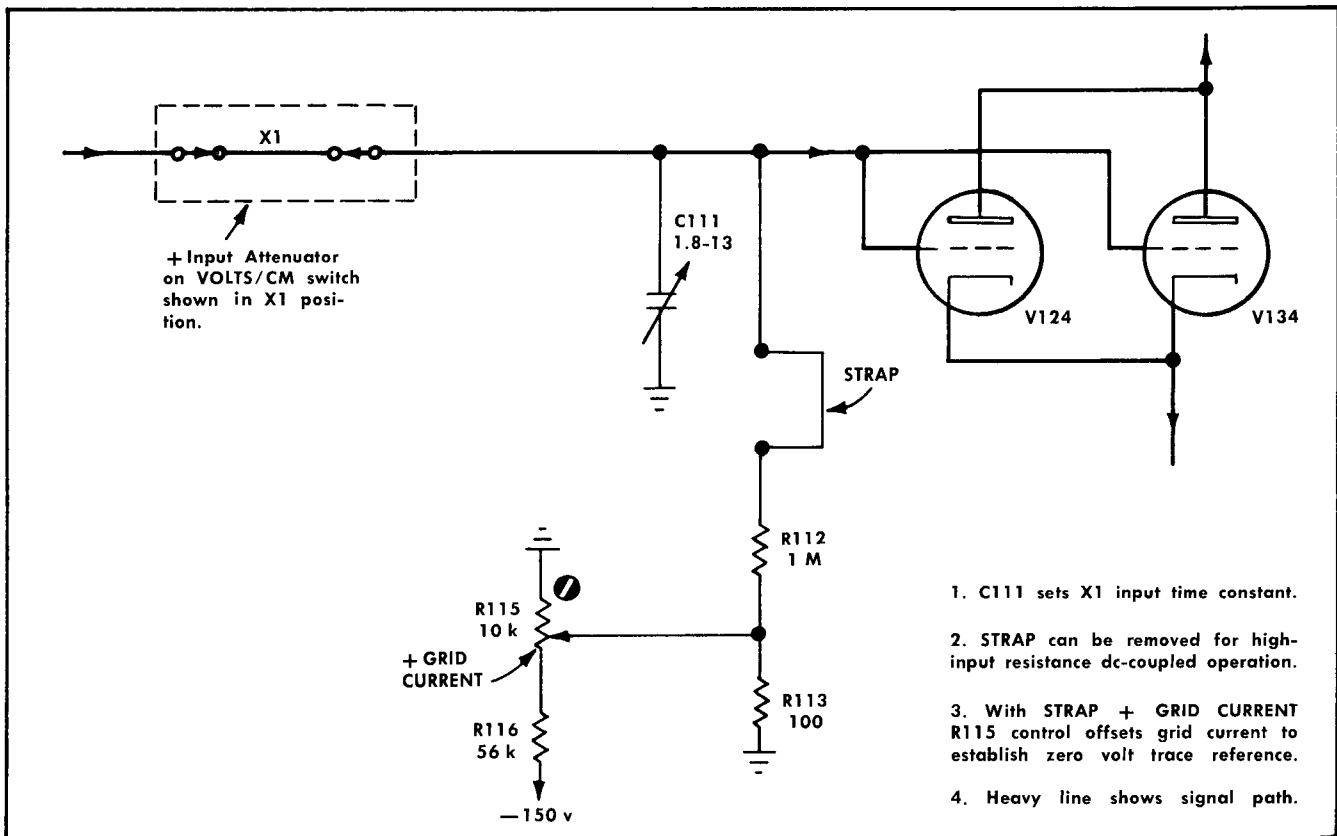

Fig. 3-2. Simplified grid circuit diagram of the +input side in the Input Amplifier stage.

control balances the gain of the stage so common-mode rejection requirements can be met. Adjustment of this control does not cause any dc current to flow through the wiper arm of R175 because the arm is connected to a potential which is equal to the voltage on the plates of V124 and V134.

To dc balance the stage with zero volts on the grids of the tubes, two controls are involved: STEP ATTEN DC BAL COARSE and STEP ATTEN DC BAL FINE. The STEP ATTEN DC BAL COARSE control R500, as shown on the Regulated Heater Power Supply diagram, provides a differential adjustment of V124-V134 and V224-V234 heater voltages. A change in heater voltage effectively controls the cathode temperature and, hence, the grid bias of the tube. The COARSE control R500 is set so the plate currents for both sides are equal.

The STEP ATTEN DC BAL FINE control R170 (see Fig. 3-3) has a similar purpose and effect to that of the COARSE control R500, but with a much narrower range of adjustment, and without thermal time lag. Current is added to the emitter of Q144 and diverted from the Q244 emitter, or vice versa, so the collector voltages of these transistors are equalized. Thus, this control affects the dc current through both sides but not the common-mode rejection.

Variable capacitors C121 and C221 provide a small amount of positive feedback to neutralize the effects of tube inter-electrode capacitances.

C143 is a dual-section trimmer that has a common rotor for differentially adjusting the capacitances in the plate circuits. This adjustment is effective only in the presence of common-mode signals. Then, it is adjusted to equalize the two sides for maximum common-mode rejection at high frequencies.

The dc offset circuit (see Fig. 3-5) is essentially a differential amplifier with a long tail. Transistors Q154 and Q254 form the differential amplifier and Q158 is the long tail. With the DC OFFSET ON-OFF switch SW155 in the ON position, Q254 is tied to a voltage divider made up of R161, R162, R163 and R164; the base of Q154 is tied to variable voltage dividers which consist of the DC OFFSET R168 and the FINE R165 controls.

Variable controls R165 and R168 are able to swing the base of Q154 about 10 volts. This swing is converted into a differential current which adds to one side while subtracting an equal amount from the other side. Total current is held constant by Q158. The unbalanced currents in the two sides cause the trace to move up or down, depending on the direction of control rotation. Any noise generated by rotating the controls is converted into a common-mode signal by C155. The high CMRR of the stage rejects the noise.

At sensitivities from 10 mV/cm to 10 μ V/cm, actual offset is +300 mV in one direction and -300 mV in the other direction as observed on the screen. Actual offset range within the amplifier remains the same for all sensitivities. However, the offset range referred to the input connectors

Circuit Description—Type 1A7

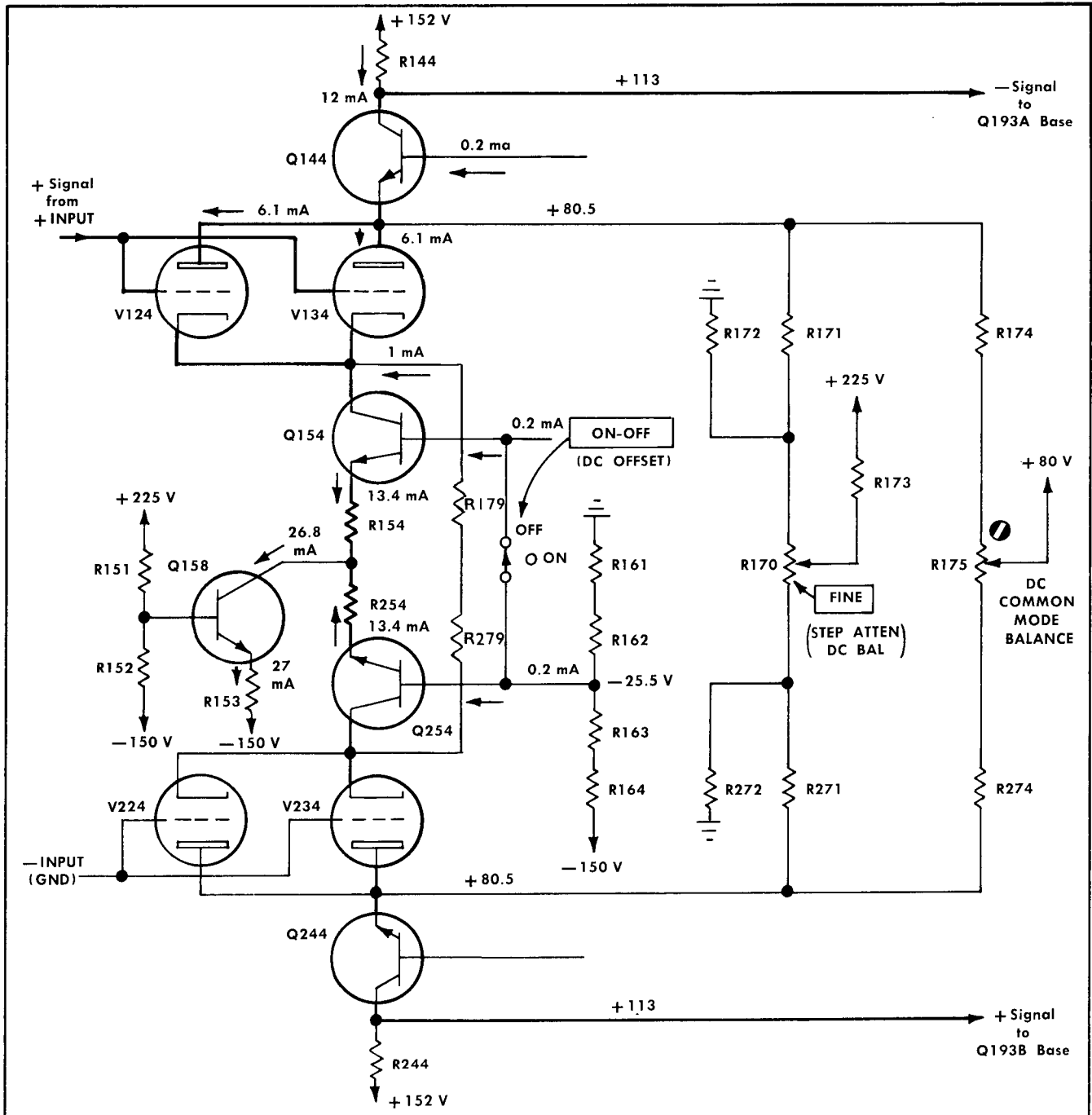

1. For the circuit description the amplifier is set for single-ended +signal-input operation. Heavy lines represent signal paths. Small arrows show direction of conventional current.
2. V124 and V134 are parallel-connected to divide the currents. Reduces noise and increases dynamic operating range.
3. V124, V134 and Q144 operate as a cascode amplifier.
4. Q154 is a long-tail constant-current source for the +INPUT side.
5. Q158 is a constant-current source for both sides.
6. Voltage gain is about 16 between grid of V124 and collector of Q144.
7. DC OFFSET ON-OFF switch is shown in the OFF position to simplify the circuit. Also, upper side of Input Amplifier circuit is shown in more detail than the lower side.

Fig. 3-3. Simplified (partial diagram) of Input Amplifier showing signal path, approximate currents and electrical location of some of the controls.

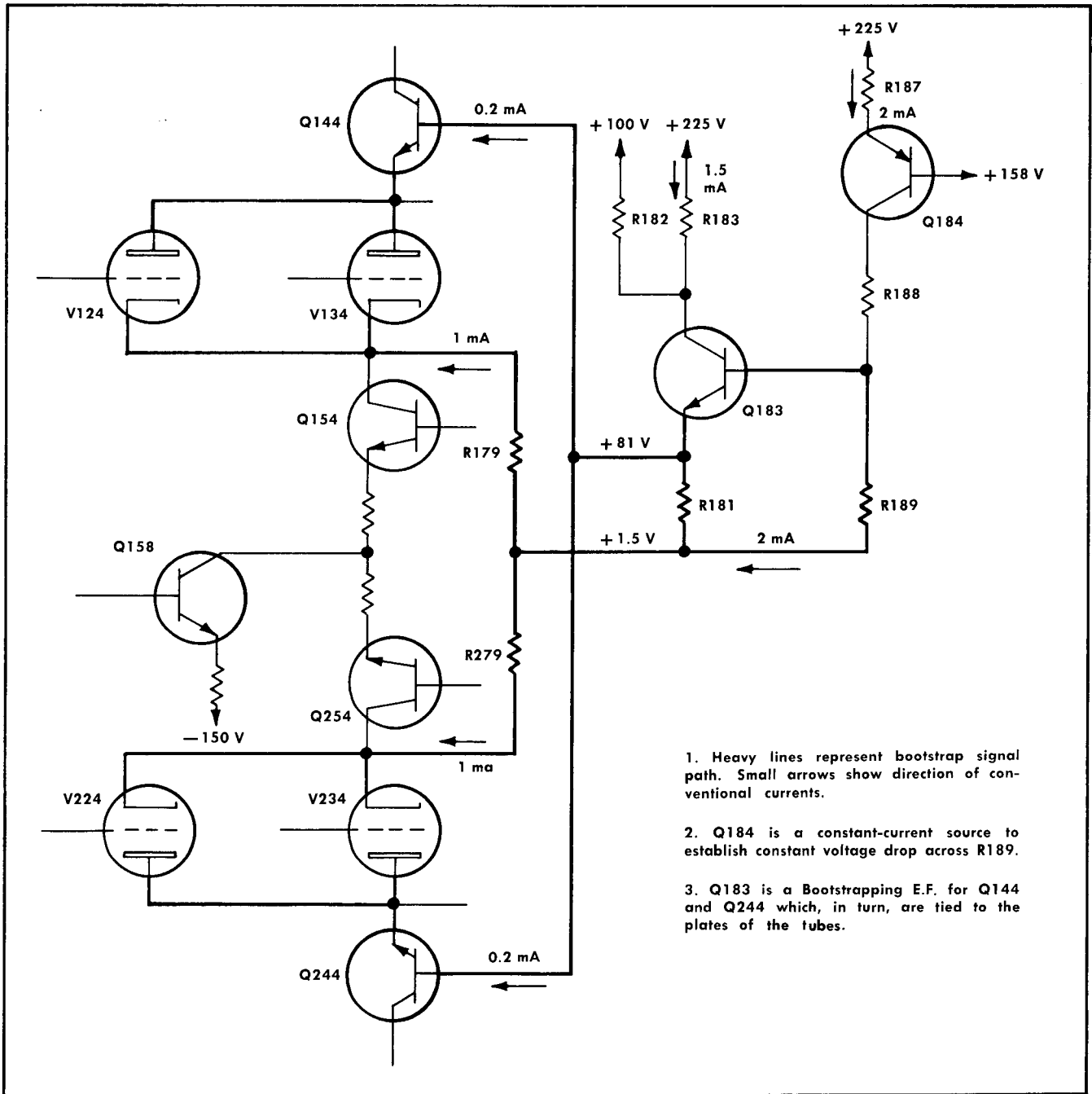

Fig. 3-4. Simplified (partial) diagram of Input Amplifier showing bootstrapping circuit and approximate center-screen currents.

is effectively multiplied by the decade attenuators as they are switched into the circuit by the VOLTS/CM switch.

Emitter Follower

Signals from the Input Amplifier are applied to the EF Q193A-Q193B stage (see Fig. 3-6). This stage provides a low-impedance drive for the following stages. When an unbalanced signal is applied to the Type 1A7, a slight dc shift will occur due to a short-term time constant in the amplifier. To compensate for this time-constant, a network

is connected between the bases of Q193A and Q193B. This network consists of C190, R290 and a DC SHIFT control R190. The control is adjusted so the trace quickly returns to zero reference when the unbalanced signal is disconnected.

Neon Bulb Driver

The Neon Bulb Driver stage consists of Q304 and Q404 with associated circuitry (see Fig. 3-7). This stage is a simple non-linear amplifier for input signals or difference voltages that are applied between the bases of the transistors. To

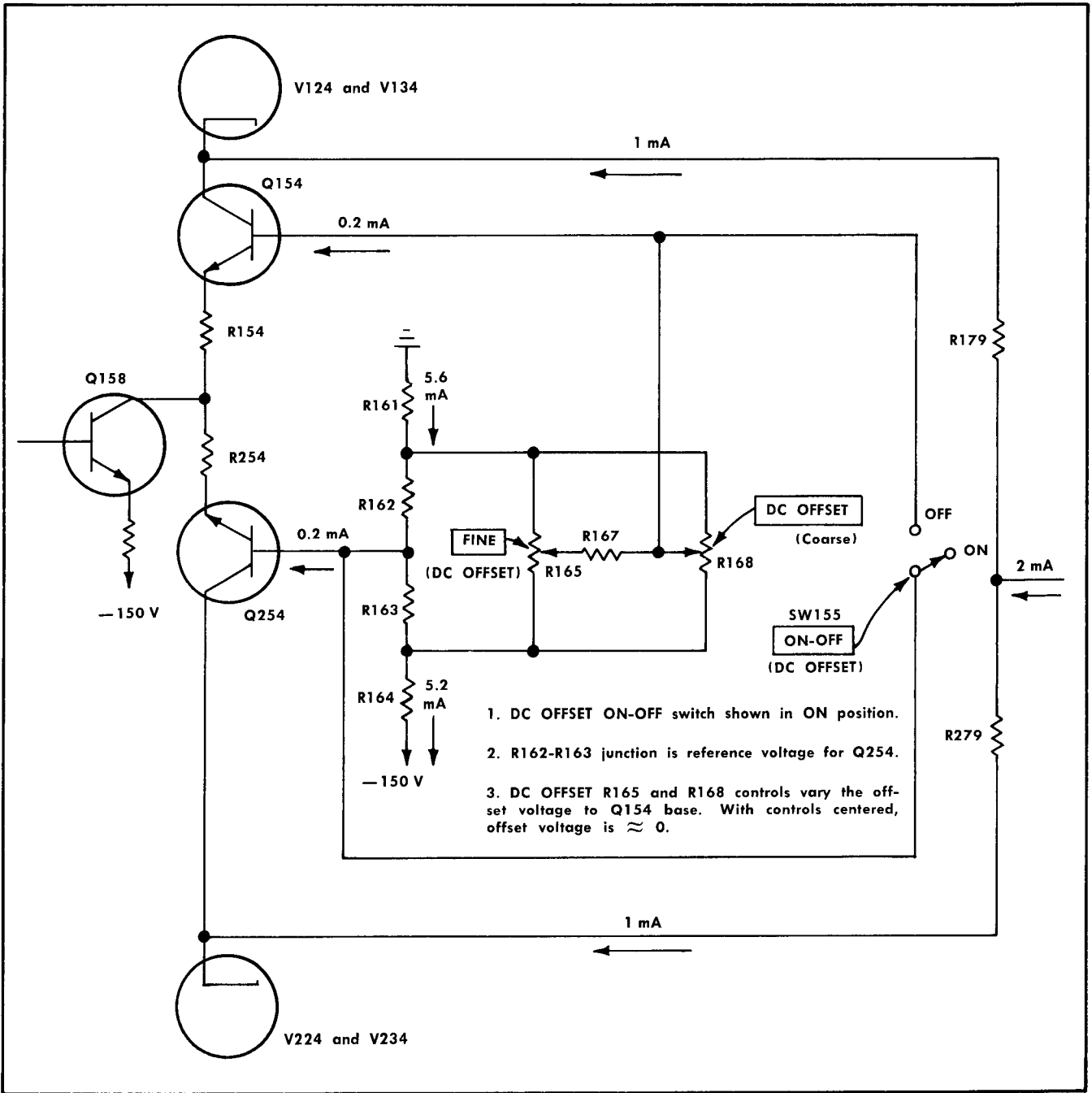

Fig. 3-5. Simplified dc offset circuit. Small arrows show direction of conventional current.

function as an amplifier, the difference voltage must be less than the Zener diode voltage which is about 6.2 volts. Under these conditions, Q304 and Q404 are conducting. R305 and R405 are the emitter resistors for their respective transistors; R304 and R404 are the collector load resistors. Gain of the stage is about 0.5.

If the difference voltage between the bases is greater than the Zener voltage, then the stage functions as a switch to turn on B309. One transistor or the other is driven into saturation while the other is driven into cutoff, depending upon the direction of applied voltage. The difference voltage between the collectors turns on B309.

For example, if the base of Q304 is driven about 7 volts negative with respect to Q404 base, Q304 cuts off. Zener diode D305 turns on and causes D405 to conduct in a forward direction as Q404 goes into saturation. Thus, the Zeners essentially connect R305 in parallel with R405 so both resistors carry the current for Q404. With Q304 cut off, its collector rises from +169 to about +221 volts; Q404 collector drops from +169 to about +120 volts. The difference voltage between the collectors is about 101 volts and B309 turns on.

If the base of Q304 is driven 7 volts positive with respect to Q404 base, the opposite action occurs. D304 goes into

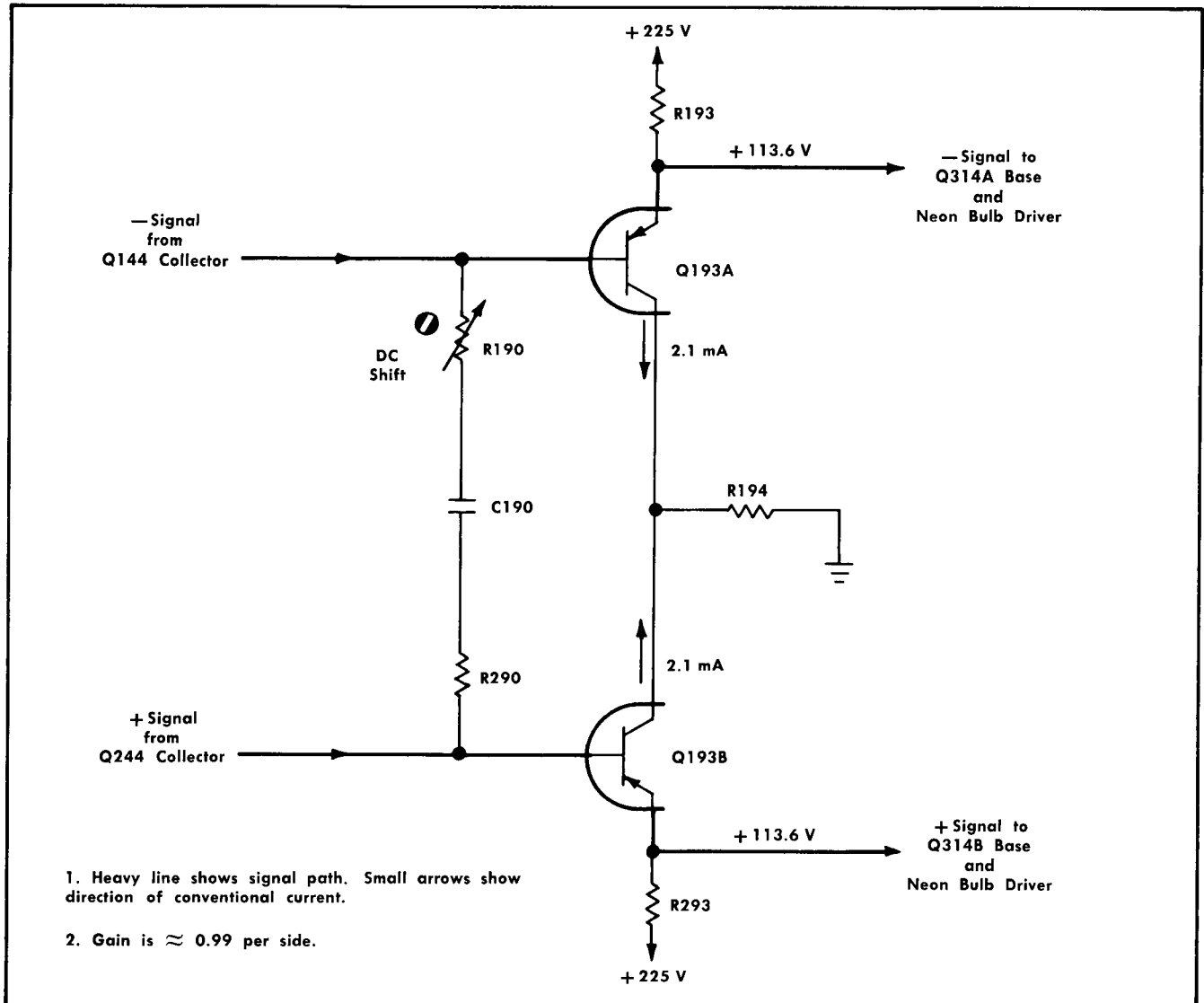

Fig. 3-6. Simplified E. F. stage showing approximate center-screen currents and signal paths.

saturation as D405 turns on and causes D305 to conduct in a forward direction. The Zeners connect R405 in parallel with R305 to complete the emitter circuit for Q304. The difference voltage between the collectors is sufficient to turn on B309.

Gain-Switching Amplifier

The Gain-Switching Amplifier stage is composed of Q314A, Q314B, Q324 and Q424 with associated circuitry. Dual transistor Q314A and Q314B is the amplifier for each side. Q324 and Q424 are the constant current transistors for Q314A and Q314B, respectively. Voltage gain for the stage is about 31 at the minimum deflection factor of $10 \mu\text{V}/\text{cm}$.

There are two gain controls in the stage: GAIN R308 and $10 \mu\text{V}$ GAIN R345. First, the GAIN control R308 is adjusted so the deflection factor is $10 \text{ mV}/\text{cm}$ when the VOLTS/CM switch is set to 10 mVOLTS and the VARIABLE control is set

to CALIBRATED. Then, the VOLTS/CM switch is set to $10 \mu\text{VOLTS}$ and the $10 \mu\text{V}$ GAIN control R345 is adjusted for a deflection factor of $10 \mu\text{V}/\text{cm}$. Once these controls are properly adjusted, the deflection factors between $10 \mu\text{V}/\text{cm}$ and $10 \text{ mV}/\text{cm}$ will be correct.

At $10 \mu\text{V}/\text{cm}$ the collector-to-collector load resistance is adjusted to exactly $50 \text{ k}\Omega$ by R345. To change the deflection factor of the unit in a 1-2-5 sequence from $10 \mu\text{V}/\text{cm}$ to $10 \text{ mV}/\text{cm}$, precision resistors are connected in shunt with the load resistance by means of the VOLTS/CM switch. For example, when the VOLTS/CM switch is set to $20 \mu\text{VOLTS}$, R335A, a $50\text{-k}\Omega$ resistor (see Attenuators schematic), is connected in shunt with the $50\text{-k}\Omega$ collector load. The two $50\text{-k}\Omega$ resistances connected in parallel cause the gain of the stage to drop by $1/2$ or $20 \mu\text{V}/\text{cm}$. This same pattern is used to change the gain for the remaining deflection factors to $10 \text{ mV}/\text{cm}$. For deflection factors from $20 \text{ mV}/\text{cm}$ to $10 \text{ V}/\text{cm}$, shunt resistors R335G, R335H and R335J are recycled as the decade input attenuators are switched into the circuit.

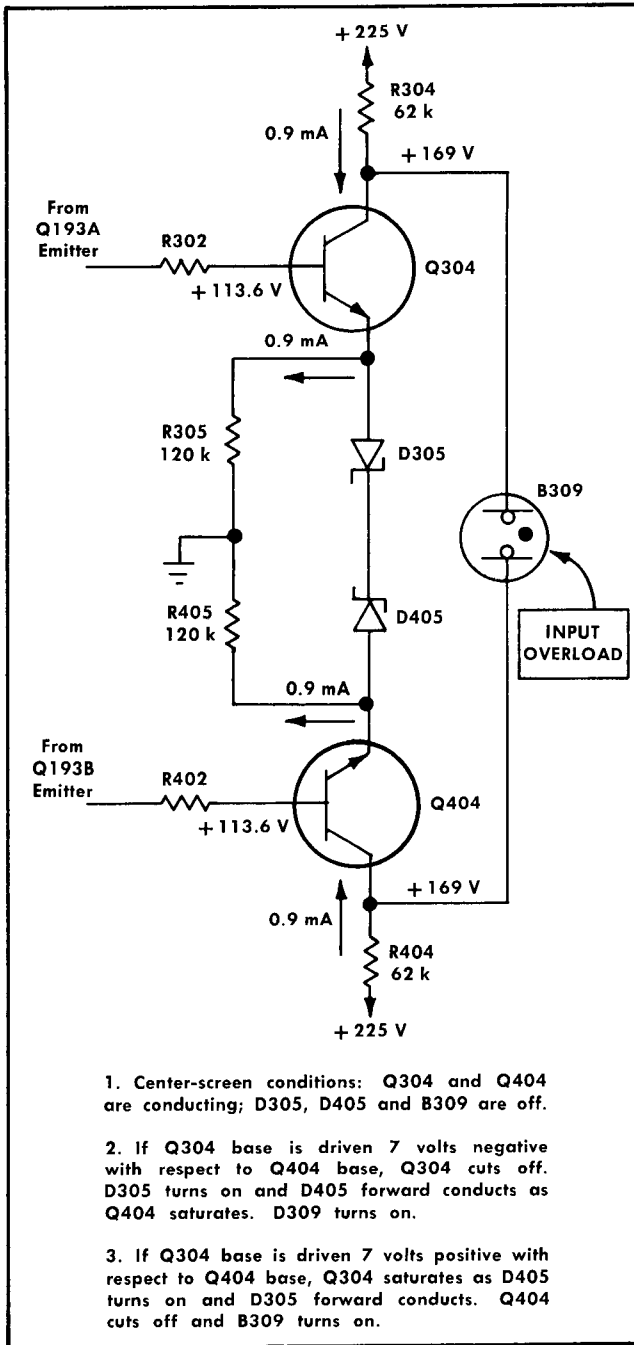

Fig. 3-7. Neon Bulb Driver stage showing approximate center-screen-current conditions.

Emitter degeneration is used to control the low-frequency response of the unit. The amount of degeneration is determined by capacitors C330A through C330F (see Bandpass Switches diagram) when used in conjunction with an emitter impedance of 1.59 k Ω . For example, if the LOW FREQ 3 dB POINT switch is set to 1, a 100 μ F capacitor (C330B) is connected into the Q314A-Q314B emitter circuit (see Fig.

3-9a). Substituting these values in the formula, $f = \frac{1}{2\pi RC}$ the 3-dB down point is 1.0 Hz. Accuracy is mostly dependent on the tolerance of the capacitors.

When the LOW FREQ 3 dB POINT switch is set to DC, C330B is used once again in conjunction with emitter resistors R331 and R431 (see Fig. 3-9b) to provide dc shift compensation for a long-term time constant in the amplifier.

In the 10 μ VOLTS to 100 μ VOLTS position, the 5R section of the VOLTS/CM switch (see Attenuators diagram) is used to insert frequency-compensating networks into the Q314A-Q314B emitter circuit. The networks aid in maintaining the frequency response to 500 kHz at these sensitivities. Another frequency-compensating network, C327 and R327 (see Vertical Output Amplifier diagram), ensures clean transient response to 500 kHz, particularly in the least sensitive positions.

Capacitors C311 and C411 cross-neutralize the stage to prevent changes in frequency response as the VOLTS/CM switch is set to its various positions.

To make up for slight differences in beta and resistor tolerances between the two sides, an AC ATTEN BAL control (R235) is provided. This control is adjusted for minimum trace shift as the VOLTS/CM switch is set from the 10 mVOLTS to 10 μ VOLTS position. For proper adjustment of R325 the LOW FREQ 3 dB POINT switch should be in the 10 kHz position, and the HIGH FREQ 3 dB POINT switch should be in the 100 Hz position.

Output Amplifier

The Output Amplifier is a conventional push-pull amplifier which consists of Q354A, Q354B and Q364 with associated circuitry. Q354A and Q354B comprise a dual transistor which is used in the amplifier portion of the circuit; Q364 is a constant current transistor. Gain of the stage is nominally 12 when the VARIABLE control R360 is set to CALIBRATED. If the preceding stages are properly dc balanced, the voltage between the emitters of Q354A and Q354B is zero and there is no trace shift as the VARIABLE control is rotated. C351 and C451 cross-neutralize the stage so the frequency response remains constant when rotating the VARIABLE control.

In the CALIBRATED position of the VARIABLE control, SW360 is closed to short out R360 so the gain of the stage is maximum. As the control is rotated a few degrees counter-clockwise, SW360 is opened so the control can be used to vary the amount of emitter degeneration, and thus control the gain of the stage.

Transistor Q364 aids in removing any common-mode signals that might appear internally in the amplifier. High-frequency response of the Type 1A7 is controlled by shunting different capacitors across the output of the stage. Taking into consideration R373, R378, R473, R478 and the collector impedance of Q354, collector load resistors R354 and R454 cause the output resistance to be about 15.9 k Ω . Using the same formula as described for the LOW FREQ 3 dB POINT switch positions, the 15.9 k Ω output resistance in conjunction with the capacitor switched into the circuit by the HIGH FREQ 3 dB POINT switch SW330B determines the high-frequency response of the unit. In the 500 kHz position of the HIGH FREQ 3 dB POINT switch, stray capacitance is about 25 pF and the high-frequency 3-dB down point is 500 kHz. When the switch is set to 100 kHz, the stray capacitance is essentially connected in parallel with C370G (see Bandpass

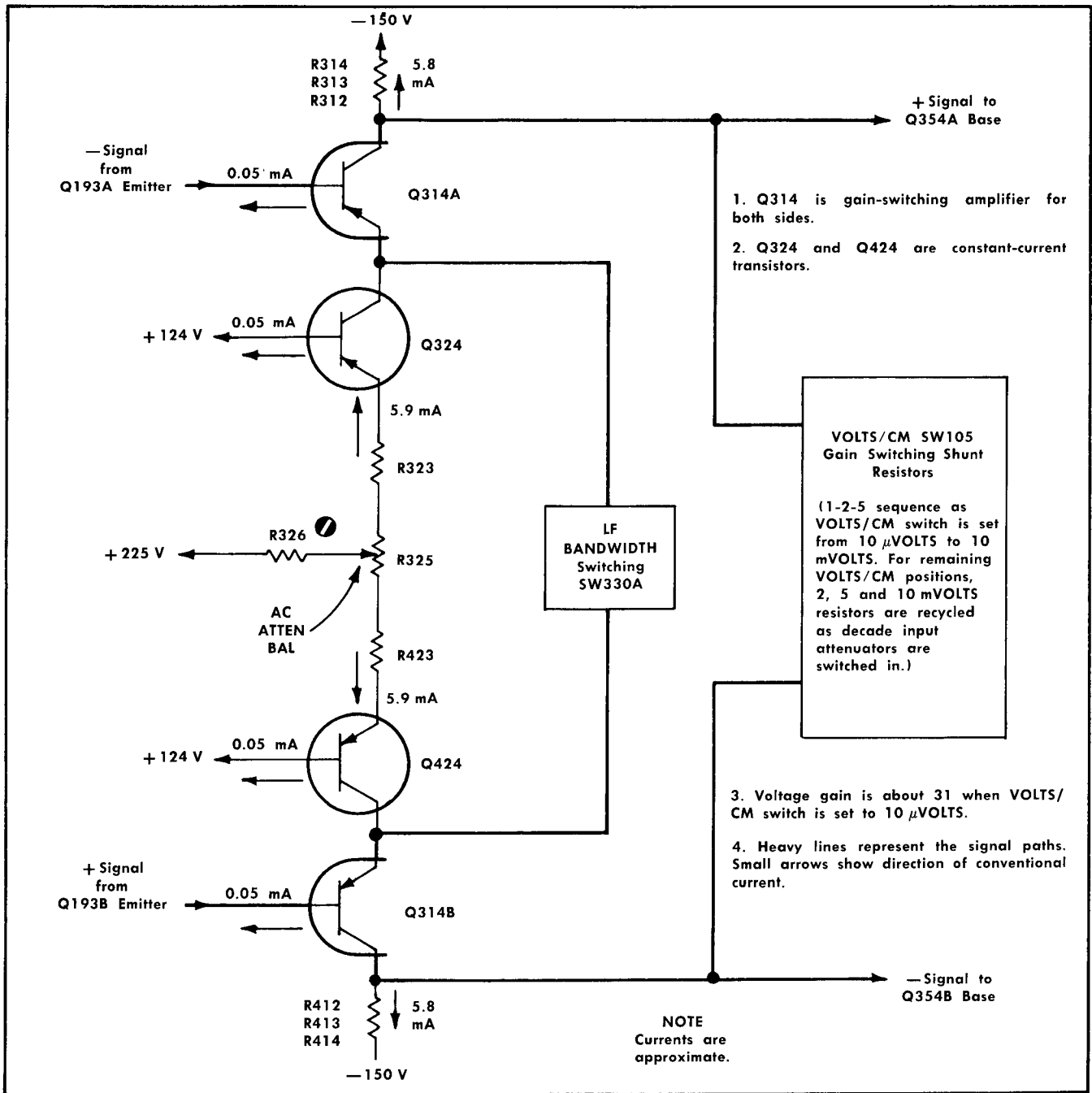

Fig. 3-8. Gain-Switching Amplifier stage.

Switches diagram). Thus the total capacitance is about 100 pF, so the upper-end bandpass is 100 kHz.

Normal vertical positioning of the trace is accomplished by rotating the POSITION control R375. The positioning range of this control is about ± 9 cm. As the control is rotated in either direction from its midrange position, the control shunts more current through one load resistor (R354 or R454) or the other. To center the trace when the POSITION control is set to midrange and the amplifier is properly dc balanced, VERT POS RANGE control R380 is provided.

Output signal polarity at pin 1 of the interconnecting plug is the same polarity as the polarity of the signal applied to the +INPUT connector. At pin 3 the signal polarity is the opposite to that of pin 1 and the +INPUT connector.

Signal Output Cathode Follower

At pin 1 of the interconnecting plug a single-ended signal is taken off and applied to a divider consisting of R492, R491 and R490. This divider lowers V493 grid voltage so the output voltage at the SIGNAL OUTPUT connector J495

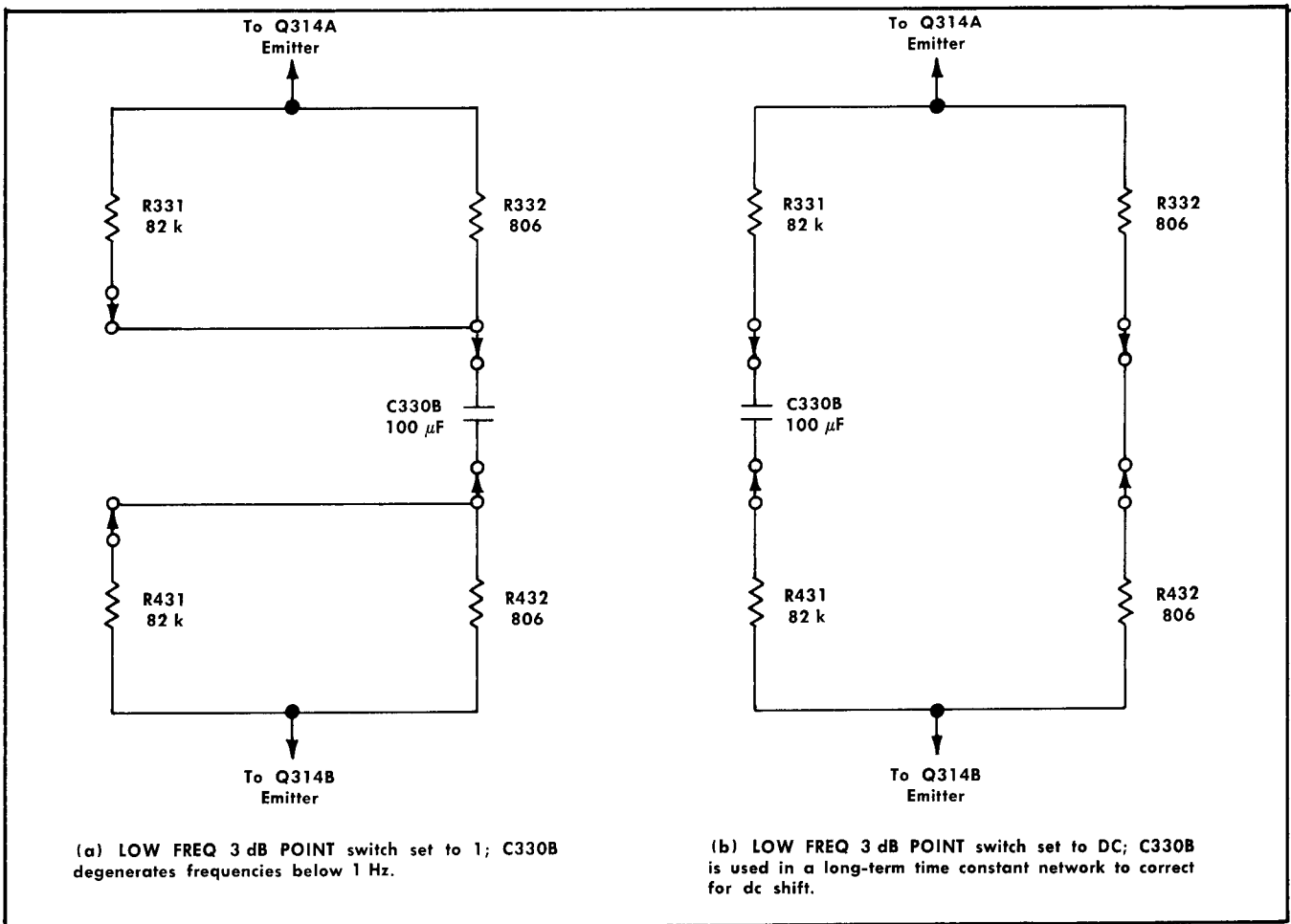

Fig. 3-9. Simplified circuit showing how C330B is used twice.

is near zero. The SIGNAL OUTPUT DC LEVEL control R490 is adjusted so the voltage at the connector is zero when the trace is positioned to graticule center.

Variable capacitor C493 is used to frequency-compensate the divider so the capacitive reactance ratio is equal to the resistance ratio. Signal polarity at the SIGNAL OUTPUT connector is the same as that at pin 1 of the interconnecting plug; i.e., positive for a positive signal applied to the +INPUT connector.

Regulated Heater Power Supply

The +75-volt regulated supply from the oscilloscope is re-regulated by Q504A, Q504B, and Q517 with associated circuitry. Q504A and Q504B form a difference amplifier. These transistors are enclosed in one case so their environmental conditions will be similar, thus reducing drift. Q517 is a voltage regulator connected in shunt with R519 and in series with the heaters (see Fig. 3-10).

Zener diode D507 is used as a reference and is driven from the regulated +25-volt source located at the junction of

R512 and R501. A relatively stable current of 7.5 mA flows through R507 to operate the Zener. D507 provides a constant dc voltage of about +9 volts at the base of Q504A with respect to ground. The base voltage for Q504B is set by divider resistors R501 and R502.

Re-regulation of the +75 volts (nominal), in the presence of a 3% difference voltage between oscilloscopes, is accomplished by varying the impedance of Q517 in a direction to compensate for the change. For example, assume the supply is lower than its nominal value of +75 volts. This will lower the base of Q504B and alter the current distribution through the difference amplifier. That is, current through Q504B will decrease a certain amount; current through Q504A will increase so the total current through R503 remains constant.

A decrease in current through Q504B causes its collector voltage to increase and raise the base of Q517. Current through Q517 increases and its impedance is lower. The decrease in Q517 impedance causes a decrease in voltage drop across Q517 and raises its emitter to the proper value.

As shown in Fig. 3-10, R519 is used to handle most of the current in the circuit while Q517 and R515 carry the

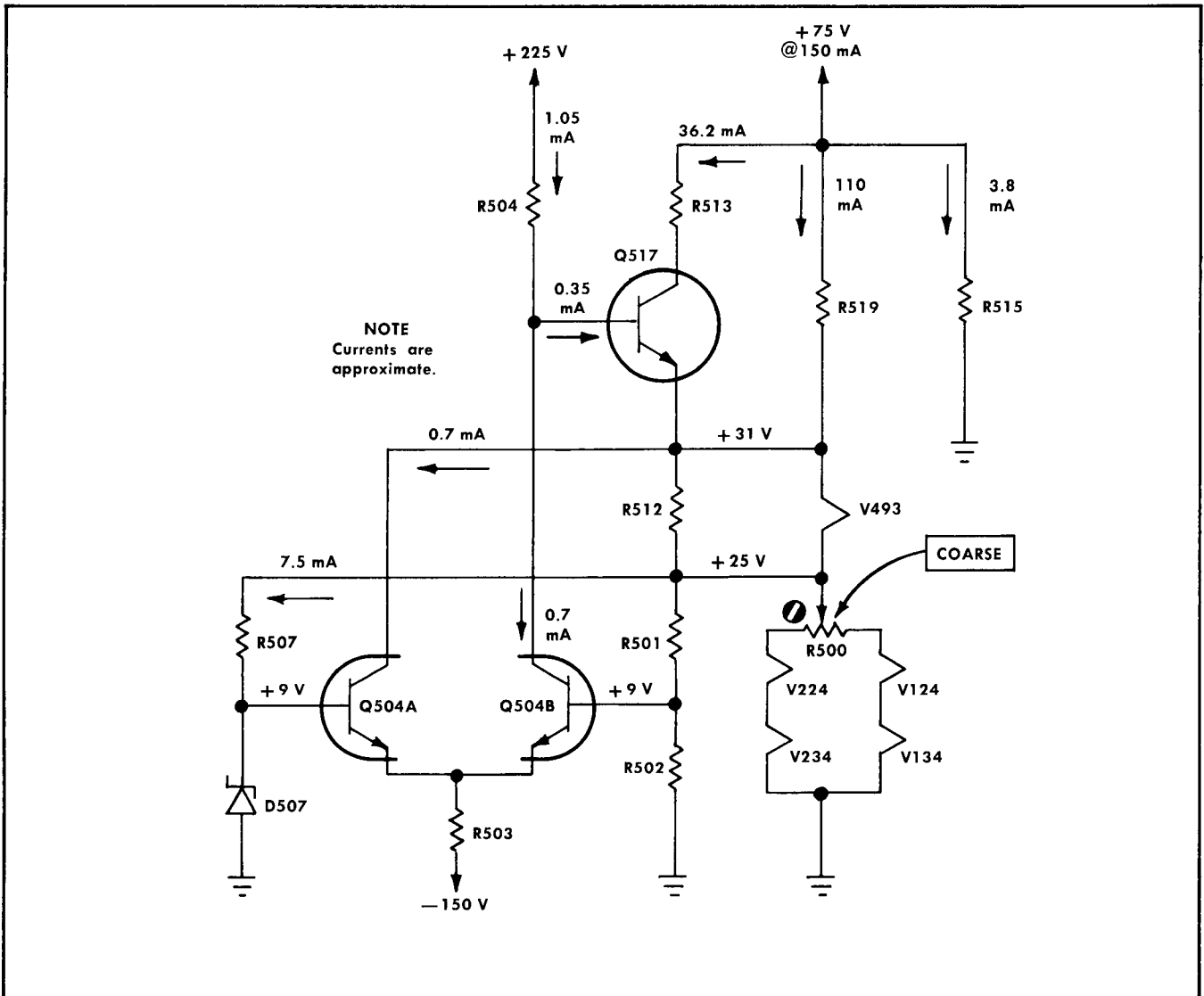

Fig. 3-10. Simplified Regulated Heater Power Supply circuit. Currents are approximate.

remainder. R512 is used as a shunt resistor to bypass the extra current not used by the heater of V493, but needed for the rest of the load circuit. As explained earlier, the

COARSE control R500 is used to differentially adjust the heaters so the grid biases for the tubes in the two sides of the Input Amplifier are equal.

SECTION 4

MAINTENANCE

PREVENTIVE MAINTENANCE

General

Preventive maintenance consists of cleaning, visual inspection, lubrication and recalibration. Preventive maintenance performed on a regular basis will help prevent failure of the unit and will improve its reliability.

Cleaning the Front Panel

Loose dust may be removed with cloth and a dry paint brush. Water and mild detergents such as Kelite or Spray White may be used.

CAUTION

Avoid the use of chemical cleaning agents which might damage the plastics used in this unit. Avoid chemicals such as benzene, toluene, xylene, acetone or similar solvents.

Cleaning the Interior

Cleaning the interior of the unit should precede calibration since the cleaning process could alter the setting of certain calibration adjustments.

To clean the interior, use low-velocity compressed air to blow off the accumulated dust. Very high velocity air stream should be avoided to prevent damage to some of the components. Hardened dirt can be removed with a soft, dry paint brush, cotton-tipped swab or cloth dampened with a water and mild detergent solution. Avoid the use of chemical cleaning agents that might damage the plastic parts.

Lubrication

The reliability of potentiometers, rotary switches and other moving parts can be increased if they are kept properly lubricated. Use a cleaning-type lubricant on shaft bushings, interconnecting plug contacts and switch contacts. Lubricate switch detents with a heavier grease. A lubrication kit containing the necessary lubricating materials and instructions is available through any Tektronix Field Office. Order by Tektronix Part No. 003-0342-00.

Visual Inspection

The unit should be inspected occasionally for such defects as poor connections, broken or damaged etched-wiring boards, improperly seated tubes or transistors and heat-damaged parts. The remedy for most visible defects is obvious. But, damage from overheating is usually a symptom of less obvious trouble; and unless the cause is determined before parts are replaced, the damage may be repeated.

Tube and Transistor Checks

Periodic preventive maintenance checks on the tubes and transistors used in the unit are not recommended. The circuits within the unit generally provide the most satisfactory means of checking tube or transistor usability. Performance of the circuits is thoroughly checked during recalibration, and substandard tubes and transistors will usually be detected at that time. More details are provided in the Troubleshooting Aids portion of this section.

Recalibration

To insure accurate measurements, the Type 1A7 calibration should be checked after each 500 hours of operation or every six months if used intermittently. Complete calibration instructions are contained in Section 6.

The calibration procedure can be helpful in isolating major troubles in the unit. Moreover, minor troubles not apparent during regular operation may be revealed and corrected during calibration.

CORRECTIVE MAINTENANCE

General

Replacement of some parts in the unit should be done by following a definite procedure. Some procedures, such as soldering and replacing components on the etched-wiring boards, are outlined in this portion of the manual.

Many electrical components are mounted in a particular way to reduce or control stray capacitance and inductance. When selecting replacement parts, it is important to remember that the physical size and shape of a component may affect its performance at high frequencies. When a repair is made, calibration of that portion of the circuit should be checked. Refer to the Calibration procedure in Section 6 and perform the applicable calibration steps.

Standard Parts

Many parts in the unit are standard electronic parts available locally. However, all parts can be obtained through your Tektronix Field Engineer or Field Office. Before purchasing or ordering, consult the parts list to determine the value, tolerance and rating required.

Special Parts

Some parts are manufactured or selected by Tektronix to satisfy particular requirements, or are manufactured for Tektronix to our specifications. These and most mechanical parts should be ordered through your Tektronix Field Engineer or Field Office. See Parts Ordering Information and Special Notes and Symbols on the page immediately preceding Section 7.

Soldering Techniques

Etched-Wiring Boards. Use ordinary 60/40 solder and a 35- to 40-watt pencil-type soldering iron on the etched-wiring boards. The tip of the iron should be clean and properly tinned for best heat transfer to the solder joint. A higher wattage soldering iron may separate the etched wiring from the base material.

The following technique should be used to replace a component on an etched-wiring board. Most components can be replaced without removing the board from the unit.

1. Grip the component lead with long-nose pliers. Touch the soldering iron to the lead at the solder connection. Do not touch the soldering iron tip directly on the board as it may damage the board.

2. When the solder begins to melt, pull the lead out gently. This should leave a clean hole in the board. If not, the hole can be cleaned by reheating the solder and placing a sharp object such as a toothpick or pointed tool into the hole to clean it out.

3. Bend the leads of the new component to fit the holes in the board. Insert the leads into the board until the component is firmly seated against the board. If it does not seat properly, heat the joint and gently press the component into place.

4. Apply the iron and a small amount of solder to the connection to make a firm solder joint. To protect heat-sensitive components, hold the lead between the component body and the solder joint with a pair of long-nose pliers or other heat sink.

5. Clip the excess lead that protrudes through the board.

6. Clean the area around the soldered connection with a flux-remover solvent to maintain good environmental characteristics and appearance. Be careful not to remove information printed on the board.

Metal Terminals. When soldering metal terminals (e.g., interconnecting plug pins, switch terminals, potentiometers, etc.), ordinary 60/40 solder can be used. The soldering iron should have a 40- to 75-watt rating with a 1/8-inch wide chisel-shaped tip.

Observe the following precautions when soldering to metal terminals:

1. Apply only enough heat to make the solder flow freely.
2. Apply only enough solder to form a solid connection; excess solder may impair the function of the part.
3. If a wire extends beyond the solder joint, clip the excess close to the joint.
4. Clean the flux from the solder joint with a flux-remover solvent to maintain good environmental characteristics and appearance.

Removing or Replacing Etched-Wiring Boards

In general, the etched-wiring boards used in the Type 1A7 are never removed unless they need to be replaced or the Attenuator board, for example, needs to be removed so the VOLTS/CM switch can be repaired or replaced. Electrical connections to the boards are made using three methods: soldered-lead connections, soldered pin connectors

and unsoldered pin connectors. Each of the boards uses one or more of these methods as follows:

Attenuator board—All soldered-lead connections.

Input Amplifier board—The three filament leads are soldered pin connectors; the pin connectors on the leads are not plugged onto pins but are inserted into terminal holes in the board and then soldered for good electrical contact. All other connections are unsoldered pin connectors; the pin connectors are plugged on the pins but not soldered to the pins.

Main Amplifier board—Output leads from pins G and H on the board are soldered-lead connections. All other connections are unsoldered pin connectors.

To remove or replace a board, proceed as follows:

1. Disconnect all leads connected to the board. Observe the soldering precautions given earlier in this section.

2. Remove all the screws holding the board to the chassis or other mounting surface. Exception: The Input Amplifier board is soldered to tube sockets mounted on a shock-mounted chassis. Remove as a unit.

3. Lift the etched-wiring board out of the unit. Do not force or bend the board.

4. To replace the board, reverse the order of removal. As a guide, correct connections of the wires are shown in Figs. 4-4, 4-5, 4-6, 4-8 and 4-9. When reconnecting the pin connectors, use care in mating the pins so the connectors are not damaged or enlarged so they fit loosely.

Removing and Replacing Switches

If either of the AC-GND-DC switches or the DC OFFSET ON-OFF switch is defective, remove and replace the switch. Use normal care in disconnecting and reconnecting the leads. (To gain access to the AC-GND-DC switches, remove the shield.) The switches can be replaced without removing the front panel overlay. First, remove the nuts and lockwashers from the switches. Then remove the switch.

Single wafers on the VOLTS/CM and BANDWIDTH switches are not normally replaced. If any of these switches are defective, the entire switch should be replaced. The switches can be ordered through your Tektronix Field Engineer either unwired or wired, as desired. Refer to the Electrical Parts List to find the unwired and wired switch part numbers.

CAUTION

When disconnecting or connecting leads to a wafer-type switch, do not let solder flow around and beyond the rivet on the switch terminal. Excessive solder can destroy the spring tension of the contact.

TROUBLESHOOTING INFORMATION

Introduction

In the event trouble develops, use the information in this portion of the manual to more effectively troubleshoot

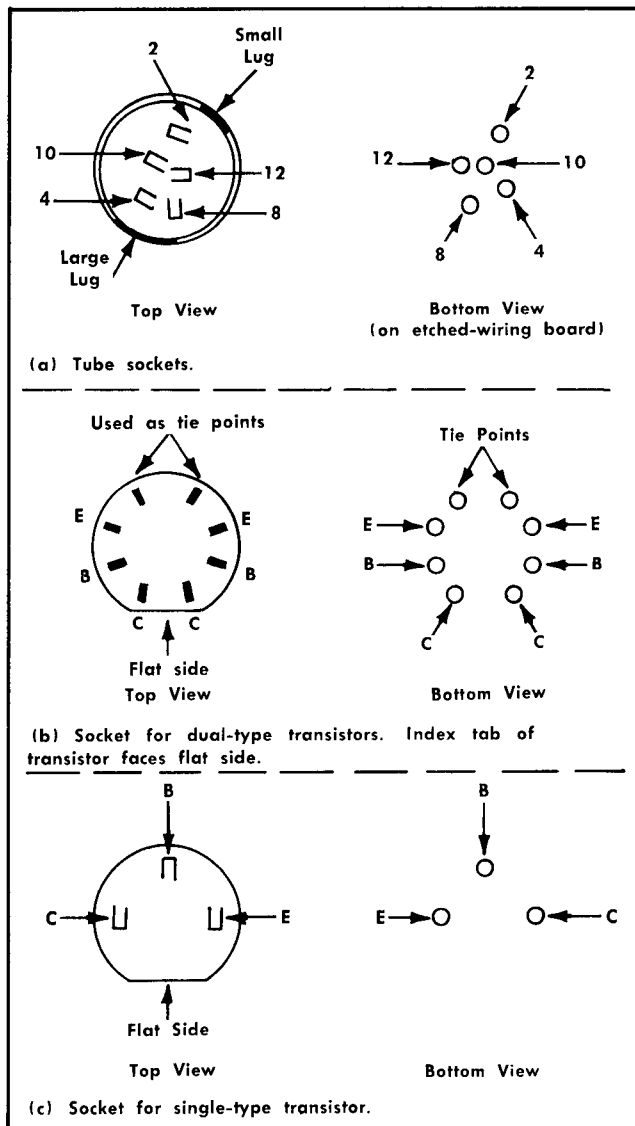

Fig. 4-1. Top and bottom views of sockets.

the Type 1A7. The information begins with preliminary checks to make, and then advances to detailed circuit troubleshooting.

Check Front-Panel Controls

Before troubleshooting, double-check the front-panel controls for proper settings. Also, check the front-panel screwdriver adjustments to determine if their settings are proper. This is important since symptoms caused by incorrect front-panel control settings are not described in this section of the manual.

If you are in doubt as to the proper settings of the controls or their function, refer to the Operating Instructions section. If the front-panel controls are properly set and you find that a trouble definitely exists, first check to determine whether the trouble is in the oscilloscope or the Type 1A7.

Isolate Trouble to Type 1A7 or Oscilloscope

When following a troubleshooting procedure, it is assumed that the oscilloscope used with the Type 1A7 is operating normally. Since this is not always the case, check the operation of the oscilloscope before attempting to troubleshoot the Type 1A7.

Troubles occurring in the oscilloscope can usually be detected by substituting another plug-in unit for the Type 1A7.

NOTE

Be sure the proper line voltage is applied to the oscilloscope used with the Type 1A7.

If the Type 1A7 is definitely at fault and not the oscilloscope, make a careful operational check of the Type 1A7. Carefully note the effect that each front-panel control has on the symptom. By analyzing such effects, you can sometimes isolate a trouble to either a defective control or circuits containing the trouble. The normal or abnormal operation of each control should indicate the checks that need to be made.

The remainder of this section deals with describing troubleshooting aids and then goes into detailed troubleshooting.

A step-by-step method for checking and adjusting the Type 1A7 is given in the Calibration section. The calibration procedure can be used to check the operational standards of the unit. Any deficiency that shows up while performing the steps can lead you to the area at fault and the possible causes.

Troubleshooting Aids

Tube and Transistor Substitution. Tubes and transistors should not be replaced unless actually defective. However, temporary substitution is often the fastest and best way to detect a defective tube or transistor.

Before substituting a tube or transistor, it is suggested that circuit conditions be checked to be sure that an exact replacement tube or transistor will not be subject to damage. In some cases, these checks will also show whether or not the tube or transistor is at fault. Fig. 4-1 shows the wiring side of the tube and transistor sockets as an aid to circuit tracing.

NOTE

Turn off the oscilloscope power before replacing tubes or transistors. When replacing Q193, Q314, Q354 or Q504 be sure the metal indexing tab faces the flat side of the socket when inserting the dual transistor into its socket. The emitter leads on these transistors are located at the opposite end from the tab (see Fig. 4-1).

When circuit conditions are known to be safe, install a tube or transistor of the same type which is known to be good and then check the unit for proper operation. If the original tube or transistor is thus proved acceptable, return it to the socket from which it came to avoid unnecessary recalibration.

Diagrams. Block and circuit diagrams are contained in the pullout pages in Section 9. The circuit diagrams contain

Maintenance—Type 1A7

component circuit numbers, voltages and waveforms. Conditions under which the voltages and waveforms were taken are also indicated on the inside portion of the Vertical Input Amplifier pullout page.

Switch Wafer Identification. Switch wafers shown on the circuit diagrams are coded to indicate the physical location of the wafer on the actual switches. The number portion of the code refers to the wafer number of the switch assembly. Wafers are numbered from the first wafer behind the driven end of the shaft to the last wafer.

The letters F and R indicate whether the front or rear of the wafer is used to perform the particular switching function. For example, 2R of the HIGH FREQ 3 dB POINT switch is the second wafer when counting back from the driven end; the letter R refers to the rear side of the wafer.

Wiring Color Code. All insulated wires used in the Type 1A7 are color-coded according to the EIA standard color code (as used for resistors) to facilitate circuit tracing. The widest color stripe identifies the first color of the code.

Power-supply voltages can be identified by three color stripes and the following background color-code: white, positive voltage; tan, negative voltage; gray, unregulated voltage.

Table 4-1 shows the wiring color code for the power-supply voltages using insulated wires for interconnection in the Type 1A7.

TABLE 4-1

Supply	Back-ground Color	1st Stripe	2nd Stripe	3rd Stripe
+225 V	White	Red	Red	Brown
+100 V	White	Brown	Black	Brown
+75 V	White	Violet	Green	Black
-150 V	Tan	Brown	Green	Brown

The remainder of the wiring in the Type 1A7 is color coded with two or less stripes or has a solid background with no stripes. The color coding helps to trace a wire from one point in the unit to another.

Resistor Color Code. Some stable metal-film resistors are used in this unit. These resistors can be identified by their light blue or gray body color. If a metal-film resistor has a value indicated by three significant figures and a multiplier, it will be color coded according to the EIA stand-

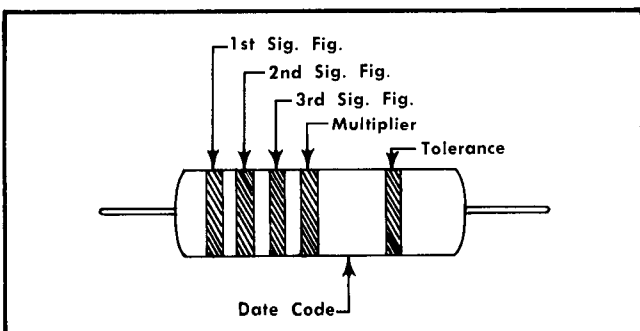

Fig. 4-2. Standard EIA color code for metal-film resistors.

ard resistor color code. If it has a value indicated by four significant figures and a multiplier, the value will be printed on the body of the resistor. For example, a 333-k Ω resistor will be color coded, but a 333.5-k Ω resistor will have its value printed on the resistor body. The color-code sequence is shown in Fig. 4-2.

Composition resistors are color coded according to the EIA standard resistor color code.

Etched-Wiring Boards. Figs. 4-4 through 4-9 show the etched-wiring boards used in the Type 1A7. Each electrical component on the boards is identified by its circuit number. The circuit boards are outlined with a blue line on the diagrams. The photographs of the boards used along with the diagrams will aid in locating the components mounted on the etched-wiring boards and to check interconnecting wiring to the boards.

Detailed Troubleshooting

Test Equipment

When preparing to circuit troubleshoot the Type 1A7, you may find useful some of the minimum equipment described here.

(1) Transistor Tester

Description: Tektronix Type 575 Transistor-Curve Tracer.

Purpose: Test semiconductors used in the Type 1A7.

(2) VOM

Description: 20,000 Ω /V dc. Be sure the test prods are suitable for use in tight places to prevent accidental shorting.

Purpose: General troubleshooting.

NOTE

The voltage on the schematics were obtained using a non-loading voltmeter. If a 20,000 Ω /V dc VOM is used, consider the loading effects of the voltmeter.

(3) Test Oscilloscope

Description: Bandwidth, 2 Hz to 300 kHz or better. Calibrated vertical deflection factors down to 5 mV/div with a 1 \times probe. Additional features, but not required: The vertical amplifier should have a differential input and a second 1 \times probe is needed.

Purpose: For low-frequency signal tracing in the amplifier stages.

(4) Flexible Cable Plug-In Extension

Description: 30 inches long, Tektronix Part No. 012-0038-00.

Purpose: Permits operating the Type 1A7 out of the oscilloscope plug-in compartment for better accessibility.

(5) BNC Coaxial Cables (two required)

Description: Equipped with BNC plug connectors on each end. Tektronix Part No. 012-0057-00.

Purpose: Use in low-frequency signal-tracing setup to apply the oscilloscope calibrator signal to the Type 1A7 and to the test oscilloscope Ext Trig input connector.

(6) BNC T Connector

Description: Fits one BNC jack and two BNC plugs. Tektronix Part No. 103-0030-00.

Purpose: Use in a low-frequency signal-tracing setup for connecting to the two BNC coaxial cables (item 5) and to the Cal Out connector on the oscilloscope used with the Type 1A7.

(7) Miscellaneous: Replacement tubes, transistors and diodes.

Interconnecting-Plug Resistances

Table 4-2 lists the approximate resistance measured between the interconnecting-plug pins and ground of the 16-pin plug P11 located on the rear panel of the Type 1A7. These measurements were taken with the unit disconnected from the oscilloscope.

The measurements are not absolute and may vary considerably, since semiconductors in the circuitry cause dif-

ferent types of ohmmeters to give different readings. Significant differences between ohmmeter types are: (1) the amount of internal voltage they use, (2) the current required to obtain full-scale deflection in each range, and (3) the meter scale readings. If ohmmeters were identical, the resistance measurements given in the table would be typical.

To allow for differences between ohmmeter types, blank columns are provided in the table for logging your own measurements. Space at the top of the columns is provided to record the type of meter used, model number and the Type 1A7 serial number.

Troubleshooting Chart

Table 4-3 is a troubleshooting chart that lists some symptoms with possible causes and probable area at fault. The third column has some references to topics that describe in more detail how to troubleshoot the Type 1A7 when there is a dc-imbalance or improper-gain troubles.

TABLE 4-2

Approximate Resistances at Interconnecting Plug¹

Pin No.	Type of Meter: VOM, Simpson Model 262			Type of Meter: Model: Type 1A7 Serial No.		
	Resistance Readings		Ohms Range Used	Resistance Readings		Ohms Range Used
	+Gnd ²	-Gnd ³		+Gnd ²	-Gnd ³	
1	17 kΩ	12.5 kΩ	RX1K			
2	0 (Gnd)	0 (Gnd)	RX1			
3	17 kΩ	12.5 kΩ	RX1K			
9	12 kΩ	14.8 kΩ	RX1K			
10	13.2 kΩ	13.9 kΩ	RX1K			
11 ⁴	12.5 kΩ	17 kΩ	RX1K			
15	440 Ω	440 Ω	RX1			

¹Measured between interconnecting plug pin and ground (chassis). Pins not listed have no circuit connection (infinite resistance).

²Plus (+) polarity ohmmeter lead connected to chassis.

³Minus (-) polarity ohmmeter lead connected to chassis.

⁴STEP ATTEN DC BAL FINE control set to midrange.

TABLE 4-3

Troubleshooting Chart

Symptoms	Checks to Make	
	Possible Causes	Area at Fault
1. No trace.	Check the supply voltages to the circuits. If a voltage is incorrect, find trouble. Some possible causes are: Defective interconnecting plug. R521, R522 or R523 open. Check tube filaments.	Check for dc imbalance in Type 1A7 stages. Refer to topic: Isolating DC Imbalance.

Troubleshooting Chart (Cont'd)

Symptoms	Checks to Make	
	Possible Causes	Area at Fault
	If trouble is not found, go to third column.	
2. Stationary trace; cannot be positioned.	Shorted capacitor on HIGH FREQ 3 dB POINT switch.	Check Output Amplifier stage.
3. Trace but no signal display when signal is applied to +INPUT connector.	Defective AC-GND-DC switch SW101. Open connection at +INPUT connector or at SW-101.	Check input circuit of V124 and V134. Refer to topic: Signal Tracing.

Troubleshooting Chart (Cont'd)

Symptoms	Checks to Make	
	Possible Causes	Area at Fault
4. Trace but no signal display when signal is applied to — INPUT connector.	Defective AC-GND-DC switch SW201. Open connection at —INPUT connector or at SW-201.	Check input circuit of V224 and V234. Refer to topic: Signal Tracing.
5. Low or incorrect deflection factor using either input.		Signal trace through Type 1A7. Refer to topic: Signal Tracing.
6. No signal out at the SIGNAL OUTPUT connector.	Check V493.	Check Signal Output stage.
7. Abnormal trace drift as line voltage changes within oscilloscope operating range.	Check Q517 and Q504. Check D507.	Check Regulated Heater Power Supply stage.
8. INPUT OVERLOAD light does not turn on when there is an overload.	Defective B309. Check Q304 and Q404.	Check Neon Driver stage.

Isolating DC Imbalance

To make the trace appear at the center of the crt, the dc output voltage at pins 1 and 3 of the interconnecting plug must be essentially equal. To make the trace appear within the usable viewing area of the crt, the dc voltage measured between pins 1 and 3 must be less than ± 0.3 volt, assuming the Type 1A7 is used with an oscilloscope having a 6-cm high viewing area.

The dc voltages at pins 1 and 3 of the interconnecting plug depend on the dc balance of each stage. Since all the amplifier stages are dc coupled, any excessive imbalance condition existing anywhere between input and output of the Type 1A7 can unbalance the output and cause the trace to be deflected out of the viewing area.

A procedure for isolating the cause of dc imbalance is as follows:

- Set the Type 1A7 front-panel controls to these positions:

VOLTS/CM	10 mVOLTS
VARIABLE POSITION	Fully counterclockwise
HIGH FREQ 3 dB POINT	Midrange
LOW FREQ 3 dB POINT	500 kHz
AC-GND-DC (+INPUT)	DC
AC-GND-DC (—INPUT)	GND
STEP ATTEN DC BAL FINE	GND
DC OFFSET ON-OFF	Midrange
	OFF

- Connect a dc voltmeter (starting from the input) between corresponding points in the amplifier as shown in Fig. 4-3 to determine the area where the imbalance originates.

For example, if the voltmeter is connected between the collectors of Q144 and Q244 and the reading is within the range indicated in the illustration, then this stage is properly dc balanced. It also means that the STEP ATTEN DC BAL FINE adjustment is properly set.

If the voltmeter is connected between the collectors of Q314, and if the reading is greater than the voltage range given in the illustration, then the dc imbalance originates in the Gain Switching stage.

- To determine the exact cause of dc imbalance in a stage, detailed checks must be made such as: check the semiconductors in the stage, check voltages and resistances. When defective components are found and replaced, check the calibration of that portion of the circuitry.

Signal Tracing

A method is described here for checking waveform amplitude and polarity at the points shown on the Vertical Input Amplifier and Vertical Output Amplifier diagrams. The technique used here is limited to the low frequencies because a flexible-cable extension is used to operate the Type 1A7 out of the oscilloscope plug-in compartment. The cable extension permits access to all sides of the Type 1A7 for detailed signal tracing and troubleshooting.

After the troubles in the Type 1A7 are found and corrected, then it is easy to go directly to the Calibration procedure in Section 6 to check frequency response and other performance requirements.

IMPORTANT

The amplitudes of waveforms shown from the input stage and on are not absolute, but can be used as a signal-tracing guide. Waveform amplitudes may vary due to stage gain, normal manufacturing tolerances and characteristics of tubes and semiconductors.

To signal trace the Type 1A7 stages, proceed as follows:

- Set the front-panel controls of the Type 1A7 to the same positions as listed in the Important note located on the inside section of the Vertical Input Amplifier schematic fold-out page.

- Connect a 30-inch plug-in cable extension between the Type 1A7 and the associated oscilloscope.

CAUTION

If the Type 1A7 is used with a Type 544, 546, or 547 Oscilloscope, be sure to pull the oscilloscope plug-in sensing switch to its outward position immediately so +75 volts is applied to the Type 1A7 regulated heater power supply.

- Apply a 2-volt peak-to-peak calibrator signal through coaxial cables to the Type 1A7 +INPUT connector and to the test oscilloscope (item 3 in Test Equipment list) Ext Trig input connector.

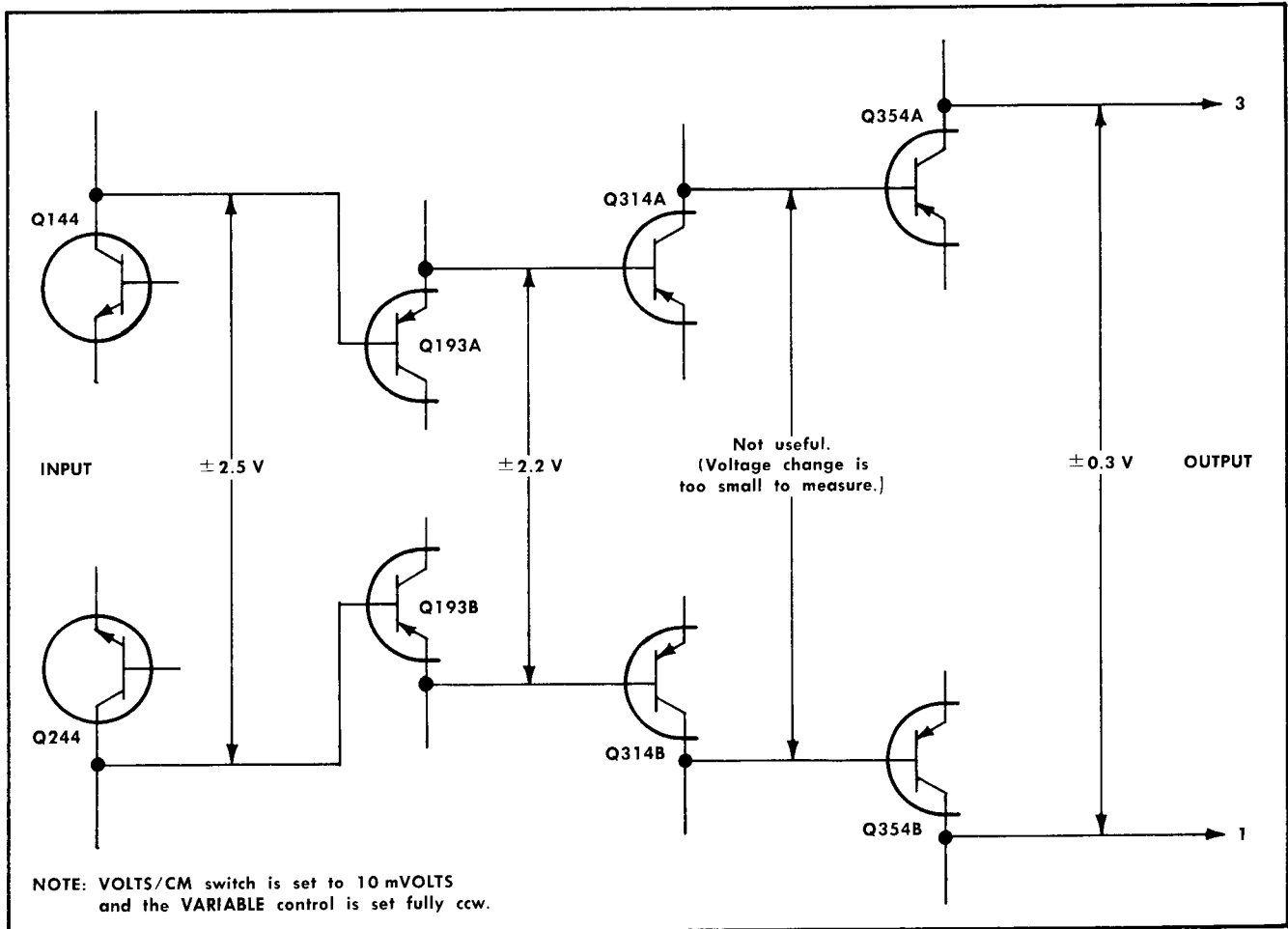

Fig. 4-3. Simplified schematic diagram showing dc balance voltage limits at various points which, if not exceeded, should position the trace into a 6-cm high viewing area.

4. Set the test oscilloscope input coupling switch to AC and set the triggering controls for +Ext triggering on the 2-volt calibrator signal.

5. Touch the test-oscilloscope probe tip to the coaxial cable connection at wafer 3F on the VOLTS/CM switch SW105. This is the +input signal connection from SW101 (+INPUT AC-GND-DC switch). Set the test oscilloscope front-panel controls so that one or two cycles of the calibrator waveform are displayed. Be sure to set the test oscilloscope triggering controls so the first $\frac{1}{2}$ cycle of the waveform is positive going. The displayed waveform on the test oscilloscope should correspond to the input waveform polarity shown at the +INPUT connector on the Vertical Input Amplifier schematic. Disconnect the probe.

6. Touch the probe tip to the desired test point in the Type 1A7 circuitry. Select a test point where a waveform is shown on the schematic. Set the test oscilloscope vertical

deflection factor to correspond to the setting given at the left side of the waveform shown on the schematic.

7. Check the displayed waveform polarity and amplitude. Then disconnect the probe.

8. Continue on to the next test point and repeat steps 6 and 7 until you reach a test point where an abnormal indication is definitely obtained. Then proceed with detailed troubleshooting checks in that stage to find the cause of the trouble. Such checks usually consist of signal-tracing between test points to check where the signal stops, semiconductor or tube substitution, voltage and resistance checks.

NOTE

The waveform at the output of the Gain-Switching Amplifier stage was obtained differentially between the collector of Q314A and Q314B using a differential-input oscilloscope with $1\times$ probes.

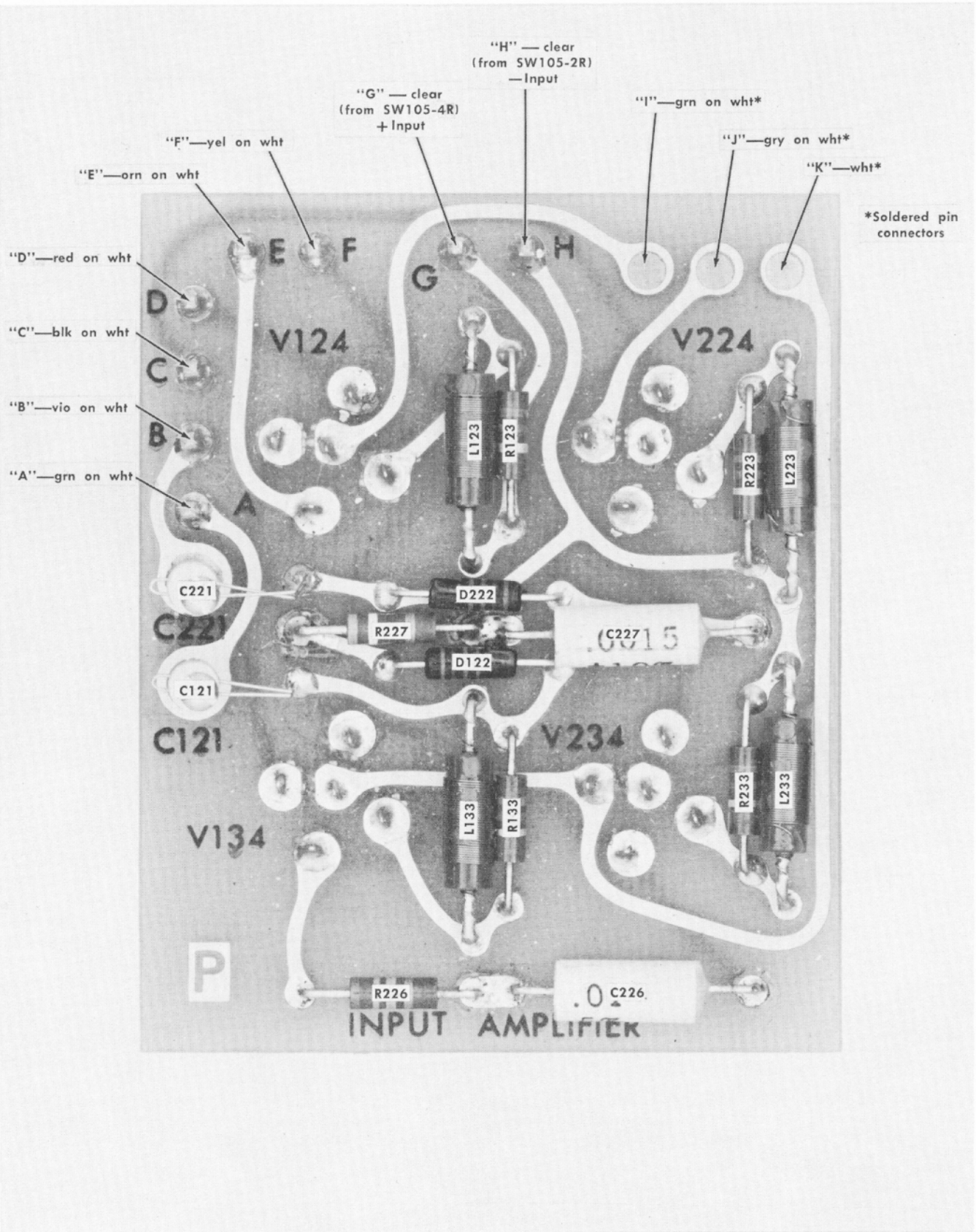

Fig. 4-4. Top view of Input Amplifier etched-wiring board.

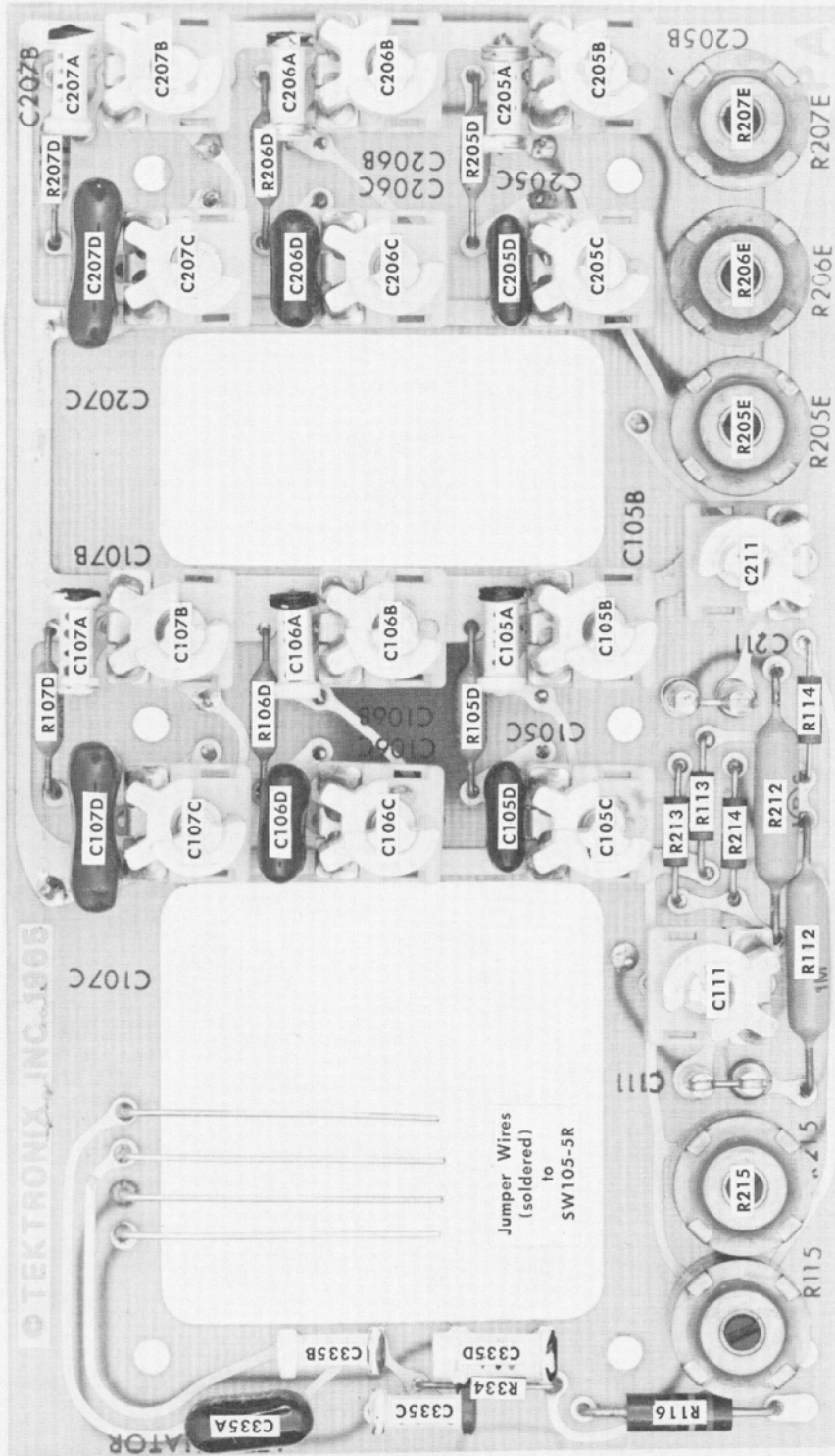

Fig. 4-5. Top view of Attenuator etched-wiring board.

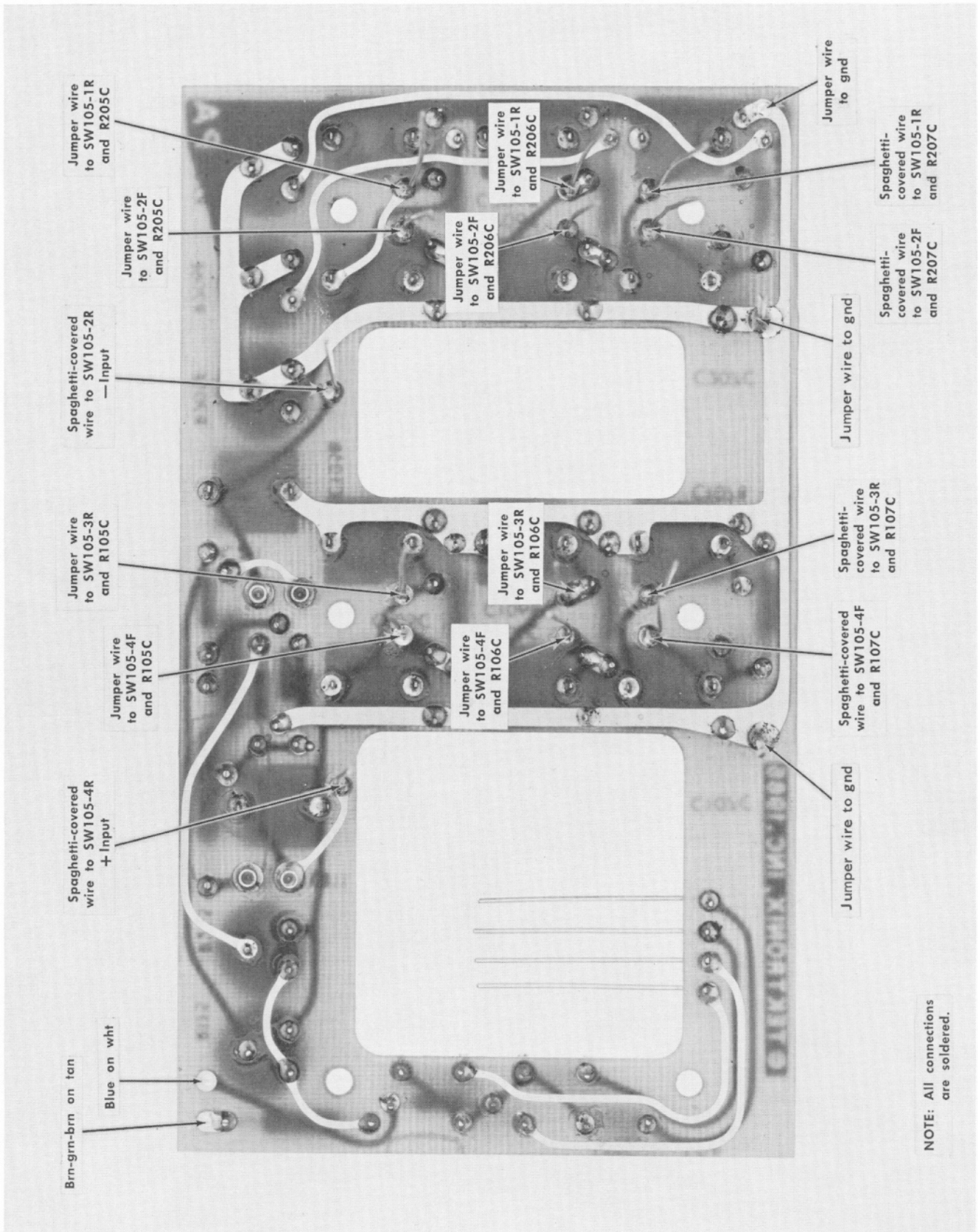

Fig. 4-6. Bottom view of Attenuator etched-wiring board identifying the interconnecting wiring.

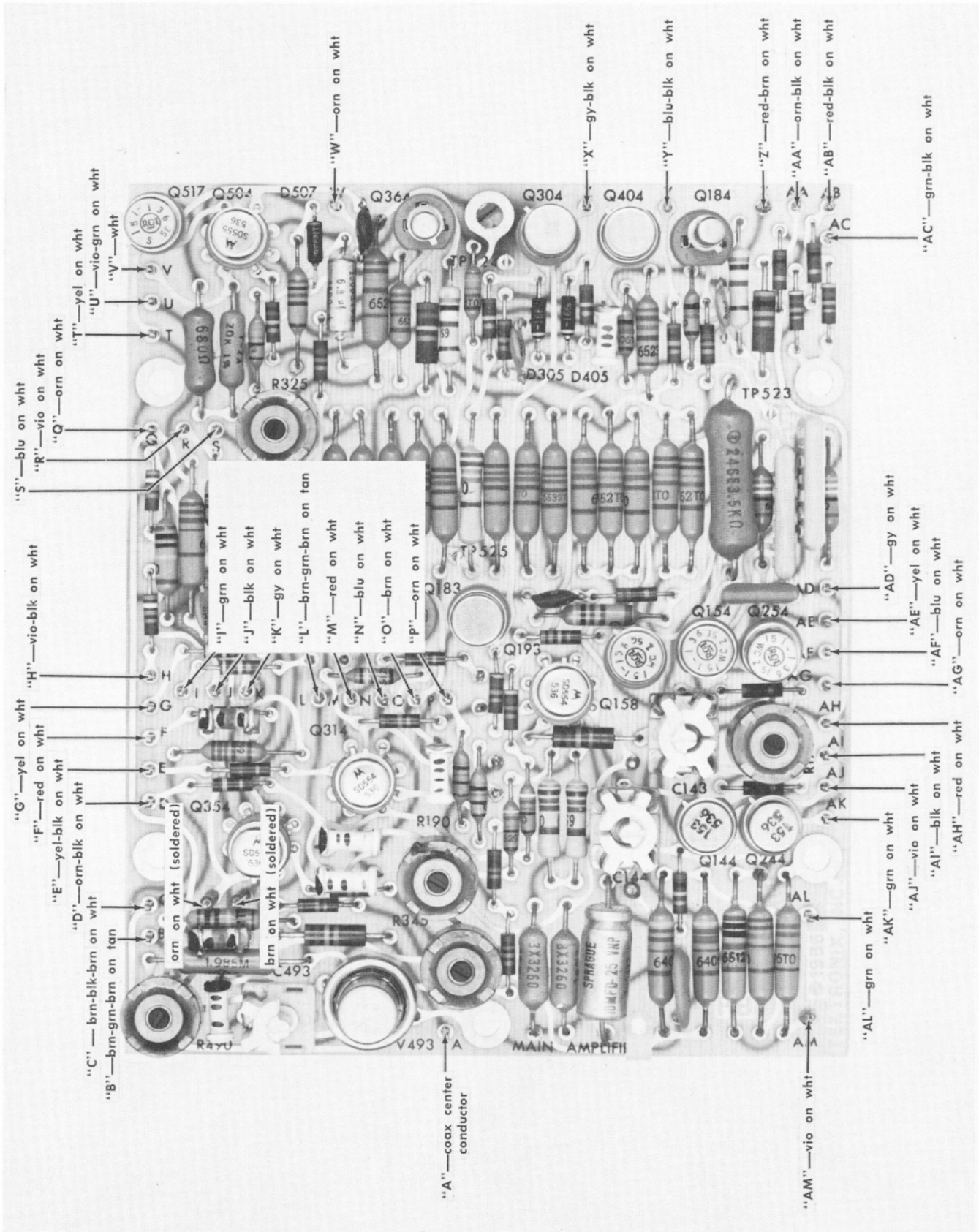

Fig. 4-8. Top view of Main Amplifier etched-wiring board showing the lettered terminals and interconnecting wiring color code.

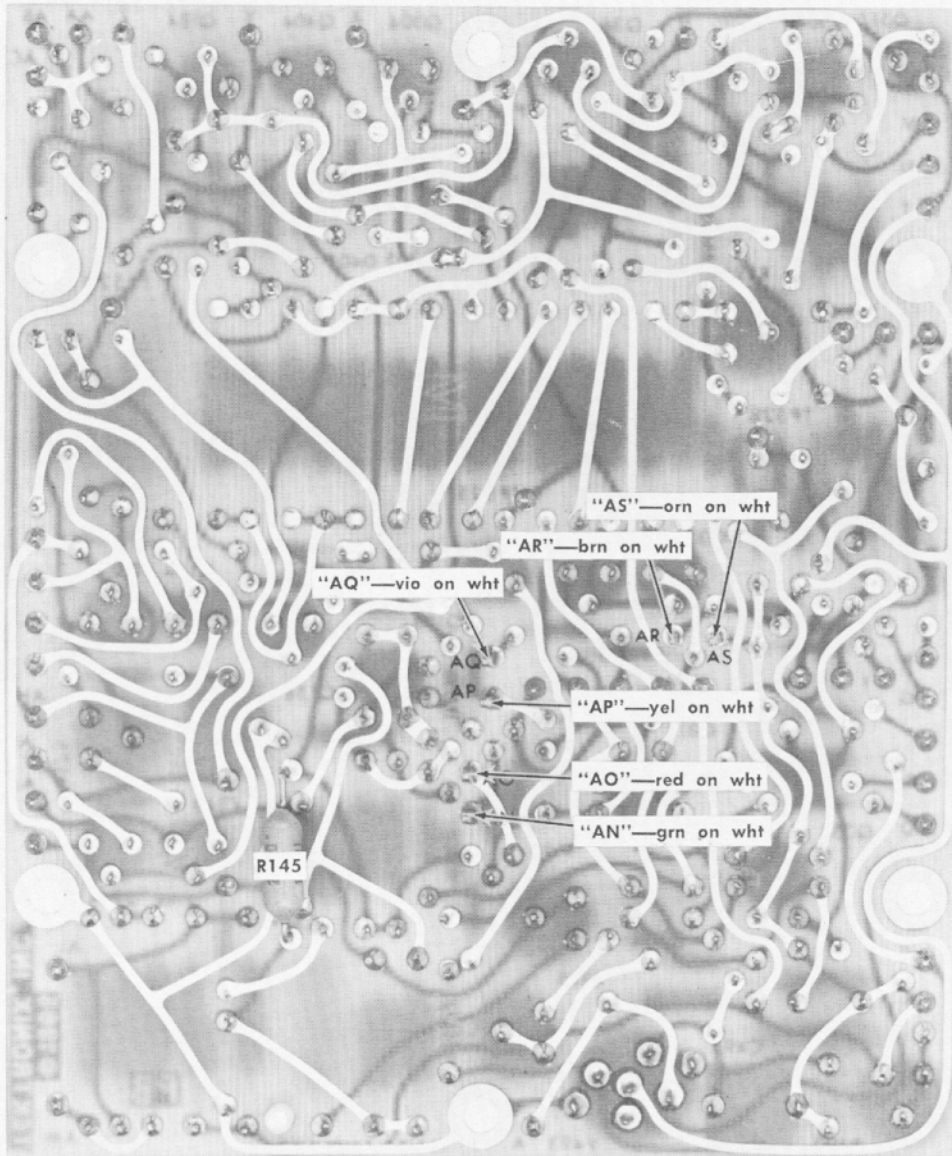

Fig. 4-9. Bottom view of Main Amplifier etched-wiring board.

SECTION 5

PERFORMANCE CHECK

Introduction

This performance check procedure is provided to check the operation of the Type 1A7 without removing the side or bottom covers from the oscilloscope.¹ This procedure may be used for incoming inspection, instrument familiarization, reliability testing, calibration verification, etc.

Failure to meet the characteristics given in this procedure indicates that the unit requires internal checks and/or adjustments. See the Calibration section of the Instruction Manual.

Recommended Equipment

The following equipment is recommended for a complete performance check. Specifications given are the minimum necessary to perform this procedure. All equipment is assumed to be calibrated and operating within the original specifications. If equipment is substituted, it must meet or exceed the specifications of the recommended equipment.

For the most accurate and convenient performance check, special calibration fixtures are available from Tektronix, Inc. Order by part number through your local Tektronix Field Office or representative.

1. 530- or 540-Series oscilloscope,² preferably a Type 544, 546 or 547. In preparing this procedure a Type 544 was used. Vertical amplifier dc balance must be adjusted or within specifications and the gain must be correct.

2. Standard Amplitude Calibrator (optional). Output frequency of about 1 kHz; peak-to-peak output amplitudes in 1-2-5 steps, 0.2 mV to 100 V; amplitude accuracy of $\pm 0.25\%$ or better at constant ambient temperature. Tektronix Part No. 067-0502-00. The Standard Amplitude Calibrator is used in performing steps 3 and 13 in the performance check procedure if greater accuracy than that provided by the oscilloscope calibrator is needed. Also, the Standard Amplitude Calibrator is needed if the oscilloscope does not have a +100 Vdc output to perform steps 7 and 8 in the procedure.

3. Test oscilloscope.³ Minimum deflection factor of 50 mV/cm; bandwidth from dc to 500 kHz or better.

4. Square-Wave Generator, Tektronix Type 105, 106, or equivalent. Output frequencies of 1 kHz and 100 kHz. Output amplitude variable from 10 to 100 volts. 100 ns or less risetime into a terminated 50-ohm cable.

5. Sine-Wave Generator. Output frequencies of 60 Hz, 100 Hz, 20 kHz and 100 kHz; output amplitude range from 2 V to 20 V peak to peak (1 to 10 V peak reference to ground).

6. RMS Voltmeter. Hewlett-Packard 3400A. Capable of reading 10 mV full scale; bandwidth of 2 MHz or better.

¹Step 3 of the procedure may require a departure from this policy in that adjustment of the internal AC ATTEN BAL may be necessary.

²Referred to as "oscilloscope" in the procedure.

³Referred to as "test oscilloscope" in the procedure.

7. Input RC Standardizer. $RC = 1\text{ M}\Omega \times 47\text{ pF}$, 2X voltage attenuation. Tektronix Part No. 011-0068-00.

8. 50-ohm termination BNC. Tektronix Part No. 011-0049-00.

9. Two 50-ohm 10X attenuators, BNC. Tektronix Part No. 011-0059-00.

10. BNC T connector. Tektronix Part No. 103-0030-00.

11. 50-ohm Pi Attenuator. Has X2, X4, X5, X10 and two X100 switches for selecting the amount of signal attenuation. Accuracy $\pm 0.25\%$. Tektronix Part No. 067-0075-00.

12. Two connector adapters. Fitted with a UHF plug and a BNC jack connector. Tektronix Part No. 103-0015-00.

13. Connector adapter. Fitted with two BNC plug connectors. Tektronix Part No. 103-0029-00.

14. BNC to binding post adapter. Binding post accepts a banana plug. Tektronix Part No. 103-0033-00.

15. BNC dual-input connector. Provides matched signal paths to both Type 1A7 input connectors. Tektronix Part No. 067-0525-00.

16. BNC clip lead adapter. Tektronix Part No. 013-0076-00.

17. Two 50-ohm (nominal impedance) coaxial cables, 42 inches long, with a BNC plug on each end. Tektronix Part No. 012-0057-00.

18. Patch cord, 18 inches long, equipped with a banana plug and jack combination connector on each end. Tektronix Part No. 012-0031-00.

19. Dc offset divider. Two resistors are needed. Accuracy is dependent on the tolerance of the resistors. Use 1% resistors as follows:

Resistor, fixed, 499 k, $\frac{1}{2}$ W, 1%, Part No. 323-0452-00.

Resistor, fixed, 1.5 k, $\frac{1}{2}$ W 1%, Part No. 323-0210-00.

PERFORMANCE CHECK PROCEDURE

General

In the following procedure, test equipment connections or control settings should not be changed except as noted. If only a partial check is desired, refer to the preceding step(s) for setup information.

The following procedure uses the equipment listed under Recommended Equipment. If substitute equipment is used, control settings or setup must be altered to meet the requirements of the equipment used.

Preliminary Procedure

1. Insert the Type 1A7 into the oscilloscope plug-in compartment.

Performance Check—Type 1A7

2. Connect the oscilloscope to a line voltage within the regulating range of the oscilloscope power supplies.
3. Turn on the oscilloscope and allow at least 30 minutes warm-up time.
4. Preset the following front-panel controls while waiting for warm up and stabilization.

Type 1A7

VOLTS/CM	10 mVOLTS
VARIABLE	CALIBRATED
POSITION	Set so trace coincides with graticule center
HIGH FREQ 3 dB POINT	500 kHz
LOW FREQ 3 dB POINT	DC
AC-GND-DC (+INPUT)	GND
AC-GND-DC (—INPUT)	GND
STEP ATTEN DC BAL FINE	Midrange
DC OFFSET ON-OFF ⁴	OFF ⁴

Oscilloscope

TRIGGERING LEVEL	About 20° cw from 0 and pushed in
MODE	AUTO
SLOPE	+
COUPLING	AC
SOURCE	NORM INT
TIME/CM	.5 mSEC
VARIABLE (TIME/CM)	CALIBRATED
HORIZONTAL DISPLAY	NORMAL
Single Sweep Switch	NORMAL
HORIZONTAL POSITION	Midrange
AMPLITUDE CALIBRATOR	OFF

Rear-panel controls

EXTERNAL CRT CATHODE ground strap	In place
CRT CATHODE SELECTOR	Toward EXTERNAL CRT CATHODE

1. Check Step Attenuator DC Balance

- a. Requirement—Capable of being balanced.
- b. Set the VOLTS/CM switch to 200 μ VOLTS.
- c. Check—That the trace can be positioned throughout the graticule area using the STEP ATTEN DC BAL FINE control.

⁴Whenever the DC OFFSET ON-OFF switch is set to OFF, the DC OFFSET (Coarse) and DC OFFSET FINE controls should be at the midrange position unless stated otherwise.

NOTE

If the Type 1A7 does not meet this requirement, refer to Section 2, page 2-3, Operational Adjustments.

2. Check AC Attenuation Balance

- a. Requirement—The trace should be within ± 2 cm of graticule center at 20 μ V/cm.
- b. Change the following control settings:

VOLTS/CM	10 mVOLTS
LOW FREQ 3 dB POINT	10 kHz
HIGH FREQ 3 dB POINT	100 Hz
- c. Using the POSITION control, position the trace to graticule center for reference.
- d. Set the VOLTS/CM switch to 20 μ VOLTS.
- e. Check—The trace should be within ± 2 cm of graticule center.

NOTE

If the Type 1A7 does not meet this requirement, refer to Section 2, page 2-4, AC ATTEN BAL Internal Adjustment.

3. Check Gain at 10 mV/cm

- a. Requirement—Vertical deflection within $\pm 1.5\%$ of VOLTS/CM switch indication.
- b. Change the following control settings:

VOLTS/CM	10 mVOLTS
LOW FREQ 3 dB POINT	DC
HIGH FREQ 3 dB POINT	500 kHz
+INPUT AC-GND-DC	DC
- c. Set the Standard Amplitude Calibrator for 50-mV square-wave output.
- d. Connect the signal from the Standard Amplitude Calibrator to the Type 1A7 +INPUT connector.
- e. Check—Crt display for exactly 5 cm of deflection (see Fig. 5-1).

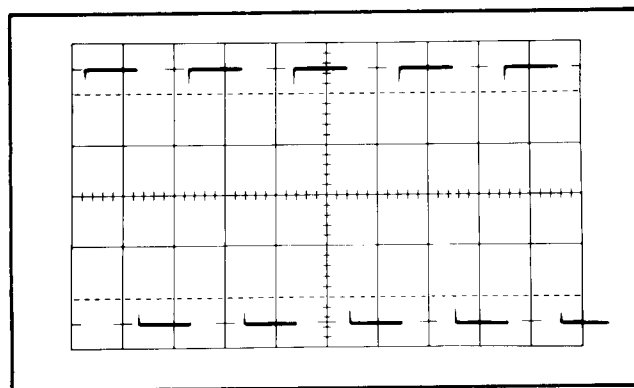

Fig. 5-1. Typical crt display showing correct vertical gain at 10 mV/cm.

f. If necessary, adjust the front-panel GAIN adjustment for exactly 5 cm of deflection.

4. Check Variable Control Range

- Requirement—At least 2.5:1 reduction in deflection when fully counterclockwise.
- Turn the VARIABLE (VOLTS/CM) control fully counterclockwise.
- Check—Maximum deflection of 2 cm or less (2.5:1 range, see Fig. 5-2).

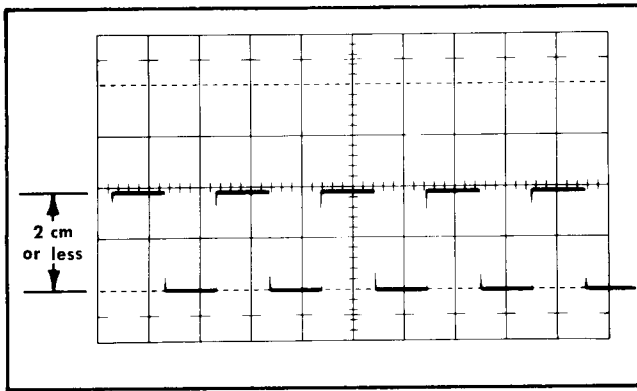

Fig. 5-2. Checking the VARIABLE control 2.5:1 ratio. This display is within the 2-cm maximum amplitude requirement.

d. Disconnect the calibrator signal.

5. Check Trace Shift Due to +Input Grid Current

- Requirement—Trace shift due to +input grid current should not exceed 2 cm at 500 μ V/cm.
- Connect a 50-ohm termination to the +INPUT connector.
- Change the following control settings:

VOLTS/CM	500 μ VOLTS
VARIABLE	CALIBRATED
+INPUT AC-GND-DC	GND
- Using the POSITION control, position the trace to the graticule centerline for reference.
- Set the +INPUT AC-GND-DC switch to AC.
- Check—Trace shift should not exceed 2 cm.

6. Check Trace Shift Due to -Input Grid Current

- Requirement—Trace shift due to -input grid current should not exceed 2 cm at 500 μ V/cm.

b. Disconnect the 50-ohm termination from the +INPUT connector; connect the termination to the -INPUT connector.

c. Set the +INPUT AC-GND-DC switch to GND.

d. Using the POSITION control, position the trace to the graticule centerline for reference.

e. Set the -INPUT AC-GND-DC switch to AC.

f. Check—Trace shift should not exceed 2 cm.

g. Disconnect the termination.

7. Check Total Dc Offset Range

a. Requirement—Combined coarse and fine range at 10 mV/cm should be ± 300 mV, +11%, -10%.

b. Change the following control settings:

VOLTS/CM	10 mVOLTS
DC OFFSET (coarse)	Fully counterclockwise
DC OFFSET FINE	Fully counterclockwise

c. Connect a binding post adapter (item 14) to the +INPUT connector.

d. Connect a 1.5 k 1% resistor (item 19) between the +INPUT connector and ground.

e. Connect one lead of a 499 k resistor (item 19) to the +INPUT connector.

f. Apply +100 Vdc from the oscilloscope calibrator through a coaxial cable and clip lead adapter (item 16) to the other lead of the 499 k resistor. Connect the ground lead of the clip lead adapter to the Type 1A7 ground. The divider applies +300 mVdc to the +INPUT connector.

g. Using the POSITION control, position the trace to the graticule centerline for reference.

h. Set these controls simultaneously:

+INPUT AC-GND-DC	DC
DC OFFSET ON-OFF	ON

i. Check—The trace should return within +3.3 cm or -3 cm with respect to graticule center.

j. Set these controls simultaneously:

+INPUT AC-GND-DC	GND
DC OFFSET ON-OFF	OFF

k. Change the following control settings:

DC OFFSET (Coarse)	Fully clockwise
DC OFFSET FINE	Fully clockwise

l. Turn off the calibrator, connect the divider resistors and connector adapter to the -INPUT connector. Reset the calibrator for +100 Vdc output.

m. Using the POSITION control, position the trace to the graticule centerline for reference.

n. Set these controls simultaneously:

-INPUT AC-GND-DC	DC
DC OFFSET ON-OFF	ON

Performance Check—Type 1A7

o. Check—The trace should return within -3.3 cm or $+3$ cm with respect to graticule center.

8. Check Input Overload Neon

a. Requirement—Turns on with 0.3 Vdc applied to the input; turns off with 0.1 V calibrator signal applied.

b. Change the following control settings:

DC OFFSET ON-OFF	OFF
DC OFFSET (Coarse)	Midrange
DC OFFSET FINE	Midrange

c. Check—Input Overload neon is turned on.

d. Set the oscilloscope calibrator for 0.1-volt square-wave output.

e. Remove the clip lead adapter, resistors and binding post adapter. Connect the coaxial cable directly to the —INPUT connector.

f. Check—Input Overload neon is extinguished.

9. Check Cross Neutralization

a. Requirement— $\leq 3\%$ aberration.

b. Set the oscilloscope calibrator for 50-mV output.

c. Set the +INPUT switch to DC.

d. Check—Aberration on lower leading corner of waveform should be no greater than $\pm 3\%$ (± 1.5 mm). See Fig. 5-3.

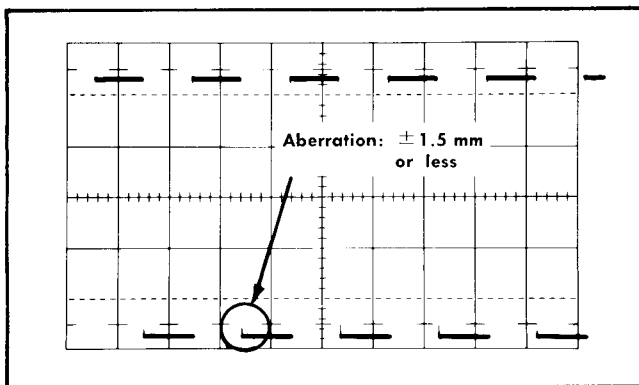

Fig. 5-3. Typical display obtained when checking cross neutralization.

e. Disconnect the signal from the —INPUT connector and apply it to the +INPUT connector.

f. Check—Aberration on upper leading corner of waveform should be no greater than $\pm 3\%$ (± 1.5 mm). Similar to Fig. 5-3 except the upper corner is the point of interest.

g. Disconnect the calibrator signal.

10. Check Gain at $10 \mu\text{V}/\text{cm}$

a. Requirement—Vertical deflection within $\pm 2\%$ of VOLTS/CM switch indication.

b. Set the +INPUT AC-GND-DC switch to GND.

c. Apply a 1-kHz signal from the Type 105 through two 10X Attenuators, coaxial cable, BNC-UHF adapter (item 12), 50-ohm Pi attenuator (item 11), BNC-UHF adapter (item 12), and a BNC-BNC adapter (item 13) to the —INPUT connector. Connect all devices in the order given.

d. Set all the 50-ohm Pi attenuator switches to the Out position (1X attenuation).

e. Adjust the Type 105 so the display is exactly 5 cm peak to peak for reference.

f. Set the 50-ohm Pi attenuator X100 and X10 switches to the In position for 1000X attenuation.

g. Change the following control settings:

Type 1A7

VOLTS/CM	$10 \mu\text{VOLTS}$
HIGH FREQ 3 dB POINT	30 kHz

Oscilloscope

TRIGGERING SOURCE	LINE
TIME/CM	5 mSec

h. Check—Crt display for exactly 5 cm (± 1 mm) of deflection (see Fig. 5-4).

NOTE

If excessive hum appears on the display, use a 3- to 2-wire adapter in the Type 105 power cord to minimize ground-loop currents.

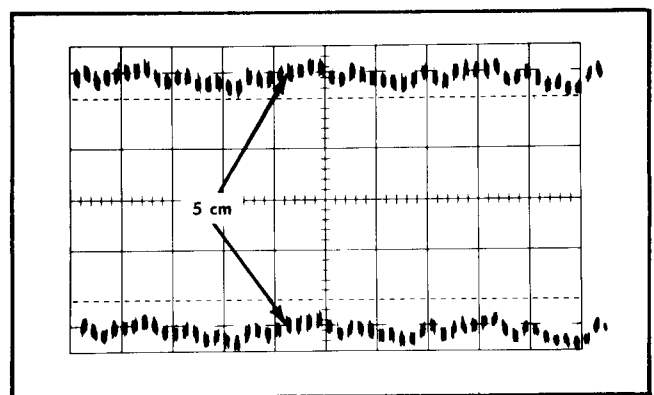

Fig. 5-4. Typical single-shot display showing correct gain at $10 \mu\text{V}/\text{cm}$.

11. Check Dc Drift

a. Requirement—Trace should stay within a ± 3 -cm graticule area for 30 seconds at $10 \mu\text{V}/\text{cm}$.

- b. Set the —INPUT AC-GND-DC switch to GND.
- c. Using the STEP ATTEN DC BAL FINE control, position the trace to graticule center for reference.
- d. Check—The trace should remain within ± 3 cm of graticule center for a period of at least 30 seconds.

NOTE

Be sure the unit has been on for at least 30 minutes, the side panels are installed on the oscilloscope and there is no source of shock or vibration to the oscilloscope or Type 1A7 during the test.

12. Check VOLTS/CM Gain Switching

- a. Requirement — Vertical deflection within $\pm 2\%$ of VOLTS/CM indication from 20 μ V/cm to 50 μ V/cm, $\pm 1.5\%$ 100 μ V/cm to 5 mV/cm.
- b. Change the following control settings:

VOLTS/CM	20 mVOLTS
—INPUT AC-GND-DC	DC
- c. Check—Using Table 5-1 as a guide, all amplitudes should be 5 cm peak to peak within stated tolerances.

TABLE 5-1

VOLTS/CM Switch Position	50-ohm Pi Attenuator Switch Position
20 μ VOLTS	In: X100, X5
50 μ VOLTS	In: X100, X2
100 μ VOLTS	In: X100
200 μ VOLTS ^a	In: X10, X5
500 μ VOLTS	In: X10, X2
1 mVOLTS	In: X10
2 mVOLTS	In: X5
5 mVOLTS	In: X2

- d. Disconnect the signal and all test equipment.

13. Check Input Attenuator Accuracy

- a. Requirement—Vertical deflection within $\pm 2\%$ of VOLTS/CM indication from 20 mV/cm to 10 V/cm.
- b. Change the following control settings:

VOLTS/CM	20 mVOLTS
+INPUT AC-GND-DC	DC
—INPUT AC-GND-DC	GND

c. Apply 0.1-V square-wave output from the Standard Amplitude Calibrator to the Type 1A7 +INPUT connector.

d. Check—Using Table 5-2 as a guide, all displays should have a vertical deflection accuracy of $\pm 2\%$.

^aFor this position and the remaining positions in the table, set the oscilloscope SOURCE switch to NORM (INT) and the TIME/CM switch to .5 mSEC. Set the Type 1A7 HIGH FREQ 3 dB POINT switch to 500 kHz.

TABLE 5-2

VOLTS/CM Switch Position	Calibrator Output (Peak to Peak)	Vertical Deflection (Accuracy: $\pm 2\%$)
20 mVOLTS	0.1 Volt	5 cm, ± 1 mm
50 mVOLTS	0.2 Volt	4 cm, ± 0.8 mm
.1 VOLTS	0.5 Volt	5 cm, ± 1 mm
.2 VOLTS	1 Volt	5 cm, ± 1 mm
.5 VOLTS	2 Volts	4 cm, ± 0.8 mm
1 VOLTS	5 Volts	5 cm, ± 1 mm
2 VOLTS	10 Volts	5 cm, ± 1 mm
5 VOLTS	20 Volts	4 cm, ± 0.8 cm
10 VOLTS	50 Volts	5 cm, ± 1 mm

- e. Disconnect the Standard Amplitude Calibrator signal.

14. Check Input Attenuator Compensation

- a. Requirement—Optimum square-wave response with minimum rolloff, overshoot or tilt.
- b. Apply a 100-V square-wave signal from the oscilloscope calibrator through a coaxial cable and a 47-pF input RC standardizer (item 7) to the +INPUT connector. Connect all items in the order given.

c. Check—Top of square wave for minimum rolloff, overshoot or tilt (see Fig. 5-5). Repeat check at each VOLTS/CM switch position from 5 VOLTS through 10 mVOLTS. Set the oscilloscope calibrator for proper output to maintain a 4- or 5-cm display amplitude.

- d. Change the following control settings:

+INPUT AC-GND-DC	GND
—INPUT AC-GND-DC	DC

e. Disconnect the signal from the +INPUT connector and connect it to the —INPUT connector.

f. Check—Bottom of square wave for minimum rolloff, overshoot or tilt (similar to Fig. 5-5a). Repeat check for each VOLTS/CM switch position from 20 mVOLTS through 10 VOLTS. Maintain 4 or 5 cm of amplitude by setting the oscilloscope calibrator for proper output.

- g. Disconnect the signal.

15. Check Dc Common Mode Balance

a. Requirement— $\geq 50,000:1$ when a 100-Hz 20 V peak to peak sine-wave signal is dc-coupled to the Type 1A7.

- b. Change the controls as follows:

Type 1A7

—INPUT AC-GND-DC	GND
------------------	-----

Oscilloscope

HORIZONTAL DISPLAY	EXT
EXTERNAL HORIZONTAL	1
VOLTS/CM	

Performance Check—Type 1A7

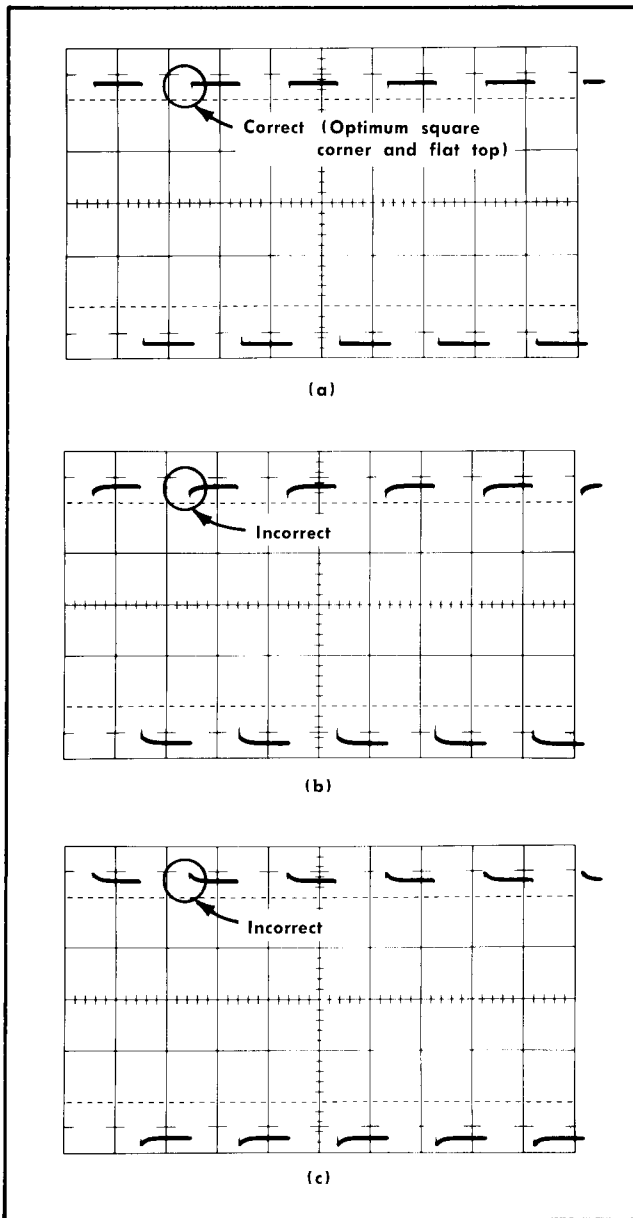

Fig. 5-5. (a) Typical crt display showing correct input attenuator compensation. (b) and (c) show incorrect compensation.

c. Apply a 20 V calibrator signal to the oscilloscope EXTERNAL HORIZ IN connector.

d. Adjust the oscilloscope VARIABLE (EXTERNAL HORIZONTAL VOLTS/CM) control so the horizontal deflection is 2 V/cm (see Fig. 5-6a).

e. Disconnect the calibrator signal.

f. Set the Type 1A7 VOLTS/CM switch to 100 μ VOLTS.

g. Apply a 100-Hz 20-V peak-to-peak signal from a sine-wave generator through a coaxial cable, T connector, and a dual-input connector (item 15) to both inputs on the Type 1A7. Connect all items in the order given.

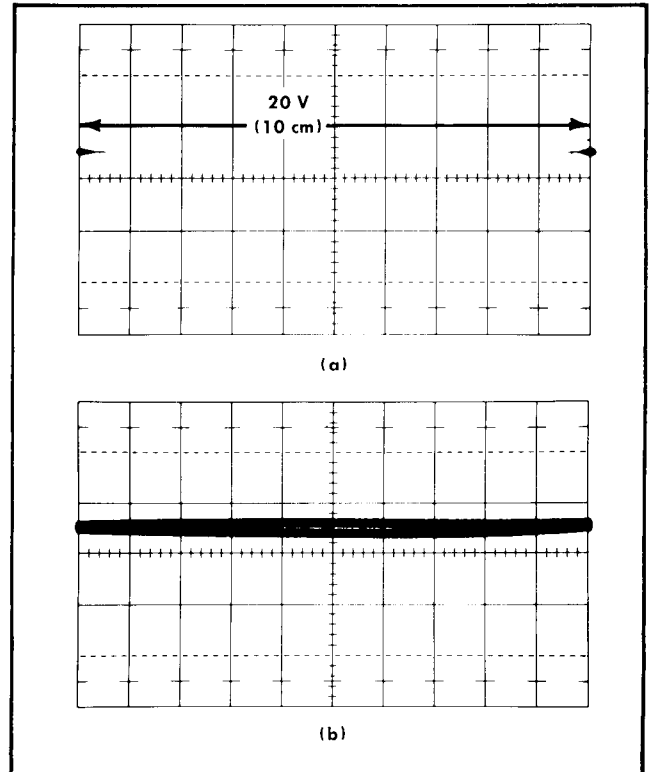

Fig. 5-6. (a) Horizontal deflection set at 20 V/10 cm. (b) A typical X-Y display obtained at 100 μ V/cm when a 100-Hz 20-V sine-wave signal is dc-coupled to the Type 1A7.

h. Install a connector adapter on the T connector. Connect a patch cord (item 18) from the connector adapter to the oscilloscope EXTERNAL HORIZ IN connector.

i. Set the sine-wave generator for exactly 20 V peak-to-peak output. The horizontal deflection should be 10 cm.

j. Set these controls simultaneously:

+INPUT AC-GND-DC	DC
-INPUT AC-GND-DC	DC

k. Check—Vertical deflection of X-Y display should not exceed 4 cm (see Fig. 5-6b).

16. Check CMRR at 100 kHz

a. Requirement— $\geq 50,000:1$ when a 100-kHz 20-V peak-to-peak sine-wave signal is dc-coupled to the Type 1A7.

b. Set the sine-wave generator for 100-kHz 20-V output.

c. Check—Vertical deflection of X-Y display should not exceed 4 cm.

17. Check CMRR at 60 Hz, Ac Coupled

a. Requirement— $\geq 2,000:1$ when a 60-Hz 20-V peak-to-peak sine-wave signal is ac-coupled to the Type 1A7. If this CMRR requirement is met, the ac low-frequency response of -3 dB at 1.6 Hz will be met also.

b. Set the VOLTS/CM switch to 10 mVOLTS.

- c. Set the sine-wave generator for 60-Hz 20-V output.
- d. Set these controls simultaneously:

+INPUT AC-GND-DC	AC
-INPUT AC-GND-DC	AC
- e. Check—Vertical deflection of X-Y display should not exceed 1 cm.
- f. Set the HORIZONTAL DISPLAY switch to NORMAL (X1).
- g. Disconnect the signal and all inter-connecting leads.

18. Check Risetime

a. Requirement—Between 0.584 and 0.875 μ s at 10 mV/cm. Equivalent to upper frequency 3-dB down point at 500 kHz, $\pm 20\%$.

b. Change the following control settings:

Type 1A7

+INPUT AC-GND-DC	DC
-INPUT AC-GND-DC	GND

Oscilloscope

TIME/CM	5 μ Sec
TRIGGERING SOURCE	EXT

c. Apply a 100-kHz signal from the Type 105 through two 10X attenuators, a coaxial cable and a 50-ohm termination (in that order) to the Type 1A7 +INPUT connector.

d. Connect a coaxial cable from the oscilloscope TRIGGER INPUT connector through a BNC-to-UHF connector adapter (item 12) to the Type 105 SYNC OUTPUT connector.

e. Adjust the Type 105 so the display is exactly 5 cm in amplitude.

f. Set the oscilloscope TIME/CM switch to .5 μ SEC.

g. Check—Risetime should be between 0.584 μ s and 0.875 μ s, as measured between the 10% and 90% levels on the rising portion of the waveform (see Fig. 5-7).

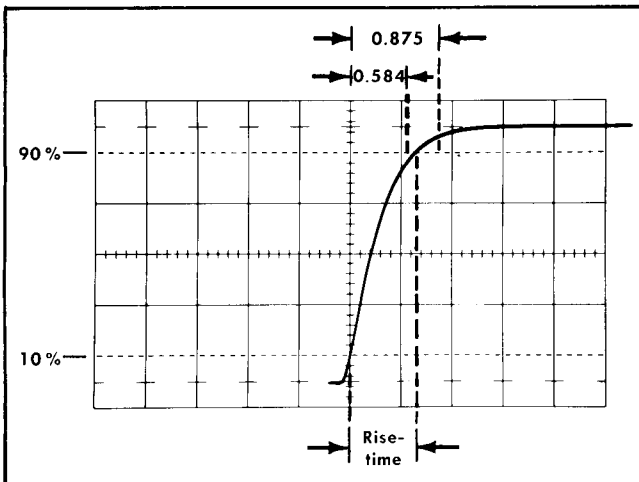

Fig. 5-7. Measuring the risetime.

h. Turn off the Type 105, disconnect the interconnecting cables, termination and attenuators.

19. Check High Frequency 3 dB Point Switch Positions

a. Requirement—Roll off in square-wave response should correspond to Fig. 5-8.

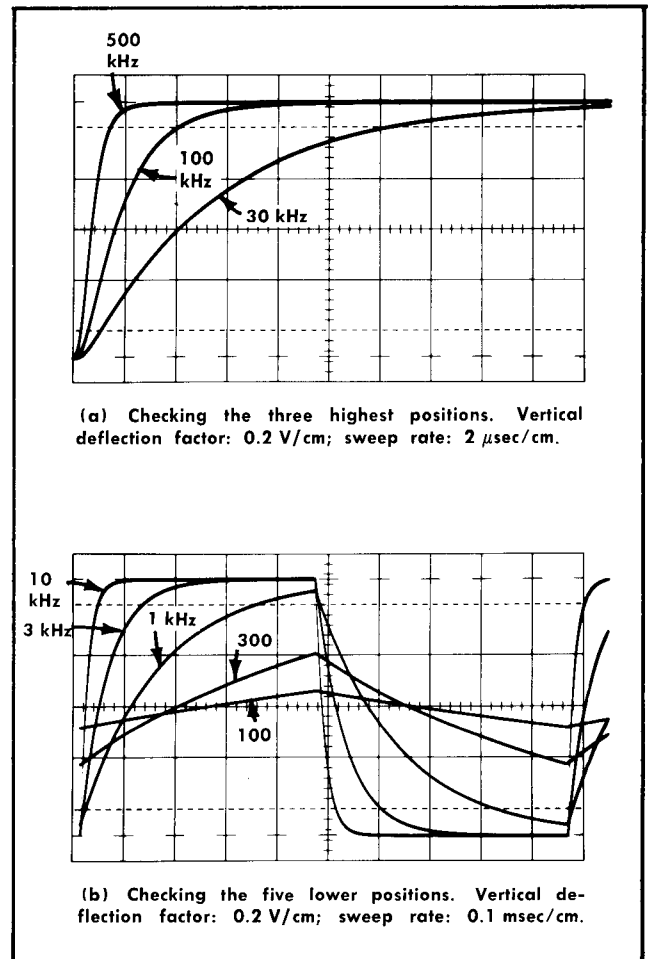

Fig. 5-8. Multiple exposure photographs showing effect of HIGH FREQ 3 dB POINT switch on a 1-kHz calibrator signal. LOW FREQ 3 dB POINT switch is set to DC.

b. Change the controls as follows:

Type 1A7

VOLTS/CM	.2 VOLTS
----------	----------

Oscilloscope

TIME/CM	2 μ SEC
AMPLITUDE CALIBRATOR	1 Volt

c. Connect a T connector to the oscilloscope TRIGGER INPUT connector.

d. Connect one coaxial cable from the T connector to the oscilloscope CAL OUT connector and a second cable from the T connector to the Type 1A7 +INPUT connector.

Performance Check—Type 1A7

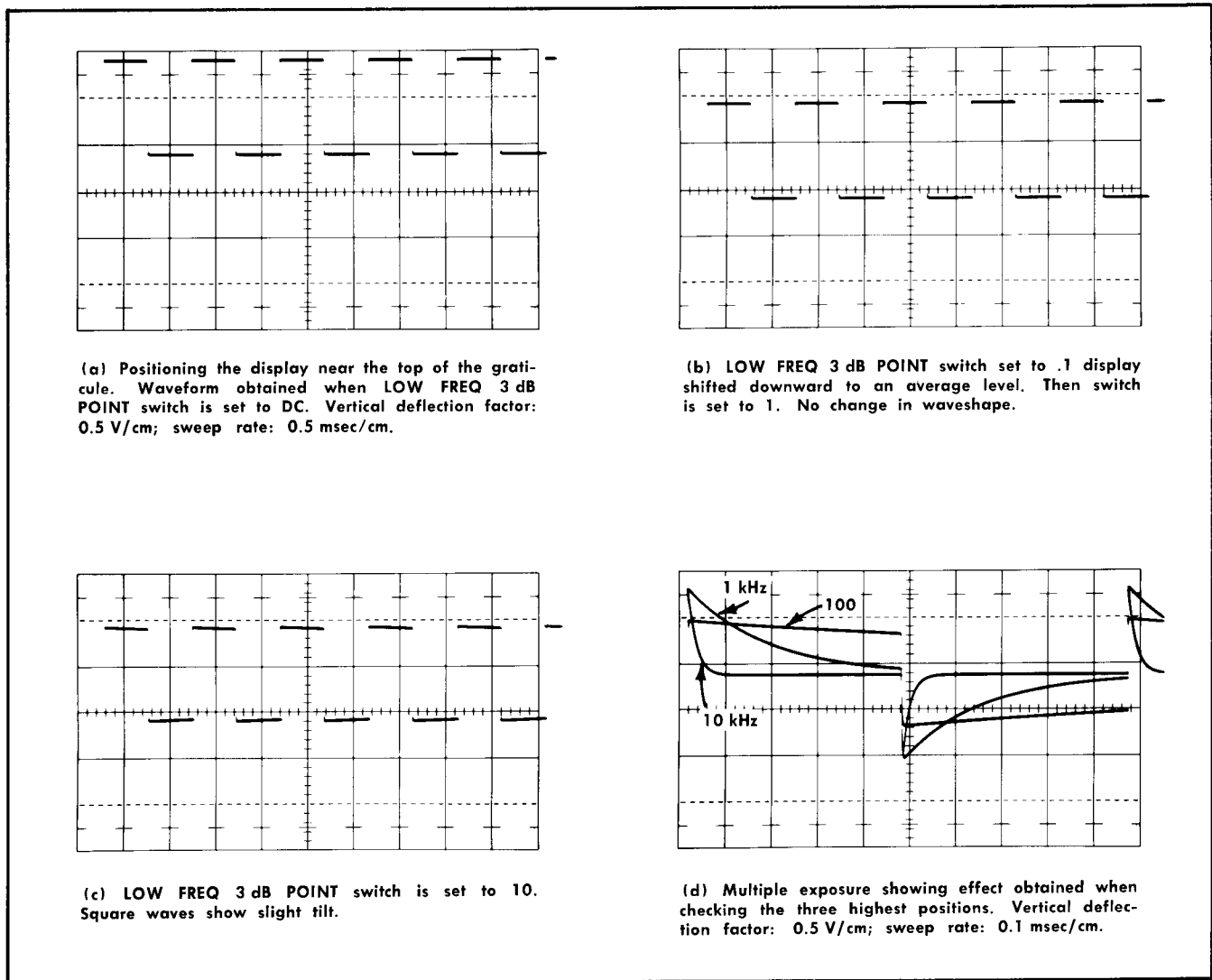

Fig. 5-9. Checking all positions of the LOW FREQ 3 dB POINT switch. HIGH FREQ 3 dB POINT switch is set to 500 kHz.

e. Check—Roll off in square-wave response for all positions of the HIGH FREQ 3 dB POINT switch. Use Fig. 5-8 as a guide.

20. Check Low Frequency 3 dB Point Switch Positions

a. Requirement—Decay in square-wave response should correspond to Fig. 5-9.

b. Change the controls as follows:

Type 1A7	
VOLTS/CM	.5 VOLTS
HIGH FREQ 3 dB POINT	500 kHz

Oscilloscope

TIME/CM	.5 mSEC
---------	---------

c. Position the display to the point shown in Fig. 5-9.

d. Check—Decay in square-wave response for all positions of the LOW FREQ 3 dB POINT switch. Use Fig. 5-9 as a guide.

e. Disconnect the coaxial cables and T connector.

21. Check Signal Output Dc Level

a. Requirement—Approximately zero volts when trace is positioned to graticule center.

b. Change the controls as follows:

Type 1A7	
VOLTS/CM	10 mVOLTS
LOW FREQ 3 dB POINT	DC

Oscilloscope

TRIGGERING SOURCE	NORM INT
TIME/CM	.5 mSEC

Test Oscilloscope

Input Coupling	DC
Volts/Cm	100 mV
Time Base	Free run at .5 msec/cm

c. Using the (vertical) POSITION controls on the Type 1A7 and test oscilloscope, position the traces on both oscilloscopes to their respective graticule centerlines.

d. Connect a coaxial cable between the Type 1A7 SIGNAL OUTPUT connector and the test oscilloscope vertical input connector.

e. Check—Position of trace on test oscilloscope should be within ± 2 cm of graticule center.

22. Check Signal Output Amplitude

a. Requirement—34 mV, $\pm 10\%$, per displayed cm.

b. Apply a 50-mV peak-to-peak signal from the oscilloscope calibrator to the Type 1A7 +INPUT connector.

c. Set the test oscilloscope VOLTS/CM switch to 50 mV/cm.

d. Check—Display amplitude on test oscilloscope crt should be 170 mV peak to peak within a tolerance of $\pm 10\%$ (3.4 cm ± 3.4 mm). See Fig. 5-10.

23. Check Signal Output Square-Wave Response

a. Requirement—Faithfully reproduces calibrator signal.

b. Check—The display on the test oscilloscope should faithfully reproduce the calibrator signal.

c. Turn off the test oscilloscope and disconnect all interconnecting cables.

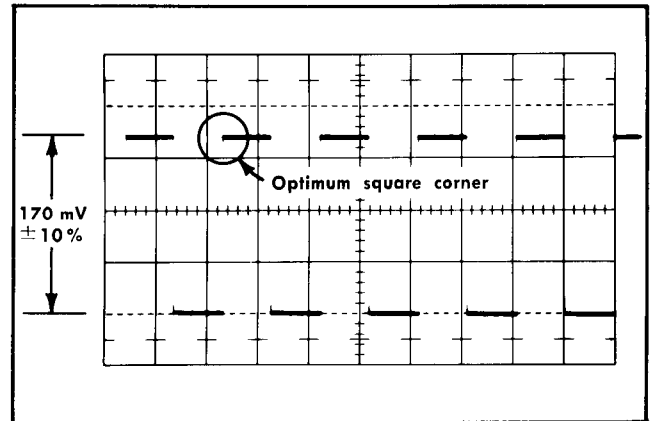

Fig. 5-10. Typical display obtained on the test oscilloscope when checking the SIGNAL OUTPUT gain.

24. Check Equivalent Input Noise

a. Requirement—Equal to or less than 10.2 mV rms measured at the SIGNAL OUTPUT connector. VOLTS/CM switch is set to 10 μ VOLTS.

b. Change the following control settings:

VOLTS/CM	10 μ VOLTS
+INPUT AC-GND-DC	GND

c. Connect an rms voltmeter between the SIGNAL OUTPUT connector and the Type 1A7 ground.

d. Check—The voltmeter reading should be 10.2 mV or less.

This completes the performance check procedure for the Type 1A7. Disconnect all test equipment. If the unit has met all performance requirements given in this procedure, it is correctly calibrated and within the specified tolerances.

SECTION 6

CALIBRATION

Introduction

The Type 1A7 should be calibrated every 500 hours or every six months if used intermittently. If transistors, tubes or other components are replaced, the calibration of the repaired circuit should be checked.

The following procedure is arranged in a sequence which will allow the unit to be calibrated with the least interaction of adjustments and reconnection of equipment. If desired, the steps may be performed out of sequence or a step may be performed individually, providing interaction between some adjustments is considered. Those that interact are pointed out within the procedure.

When performing steps individually or out of sequence, it may be necessary to refer to the preceding step(s) and/or Preliminary Procedure for additional setup information. When referring to preceding step(s), a list of the front-panel control settings is provided at major points in the procedure so a start can be made at any of those points.

NOTE

This procedure contains performance checks of the unit along with a complete calibration. Steps entitled 'Check' are the performance checks. All other steps are entitled 'Adjust'. The symbol **ⓐ** is included in the 'Adjust' title so these steps can be located easily.

As an additional aid, a calibration record is provided at the beginning of this section. It lists all the 'Check' and 'Adjust' steps. Boxes are provided so each step can be checked off as it is completed. A brief explanation below each step is included so an experienced calibrator can use the check-off list as a condensed procedure.

EQUIPMENT REQUIRED

The following equipment, or equivalent, is required for a complete calibration of the Type 1A7.

(1) 530- or 540-Series oscilloscope¹, preferably a Type 544, 546 or 547. For this procedure a Type 544 was used.

Required characteristics: Vertical amplifier dc balance must be adjusted or within specifications and the gain must be correct.

(2) Standard Amplitude Calibrator (optional).

Description: Output frequency of about 1 kHz; peak-to-peak output amplitudes in 1-2-5 steps for this procedure—0.2 mV to 100 V; amplitude accuracy of $\pm 0.25\%$ or better at constant ambient temperature. Tektronix Part No. 067-0502-00.

Purpose: For use in performing steps 4 and 20 in the calibration procedure if greater accuracy than that provided by the oscilloscope calibrator is needed. In addition, the Standard Amplitude Calibrator is needed if the oscilloscope does not have a +100 Vdc output to perform steps 8 through 10 in the procedure.

(3) Test oscilloscope².

Required characteristics: Minimum deflection factor of 50 mV/cm; bandwidth from dc to 500 kHz or better.

Purpose: Used as a signal-source monitoring oscilloscope and an indicator for calibrating the Type 1A7 Signal Output stage.

(4) Square-Wave Generator, Tektronix Type 105 or 106.

Required characteristics: Output frequencies of 1 kHz and 100 kHz. Output amplitude variable from 10 to 100 volts. 100-ns or less risetime into a terminated 50-ohm cable.

(5) Sine-Wave Generator.

Required characteristics: Output frequencies of 60 Hz, 100 Hz, 20 kHz and 100 kHz; output amplitude range from 2 V to 20 V peak to peak (1 to 10 V peak reference to ground).

(6) RMS Voltmeter. Hewlett-Packard 3400A.

Required characteristics: Capable of reading 10 mV full scale; bandwidth of 2 MHz or better.

Purpose: Used in step 31 as the preferred method for measuring noise amplitude.

(7) Input RC Standardizer.

Description: $RC = 1 M\Omega \times 47 \text{ pf}$, $2\times$ voltage attenuation; equipped with one BNC plug and one BNC jack connector fittings. Tektronix Part No. 011-0068-00.

(8) 50-ohm termination with BNC plug and jack connector fittings. Tektronix Part No. 011-0049-00.

(9) Two 50-ohm $10\times$ attenuators with BNC plug and jack connector fittings. Tektronix Part No. 011-0059-00.

(10) BNC T connector. Fits one BNC jack and accepts two BNC plugs. Tektronix Part No. 103-0030-00.

(11) 50-ohm Pi Attenuator. Has $\times 2$, $\times 4$, $\times 5$, $\times 10$ and two $\times 100$ switches for selecting amount of signal attenuation. Accuracy $\pm 0.25\%$. Tektronix Part No. 067-0075-00.

(12) Two connector adapters. Fitted with a UHF plug and a BNC jack connector. Tektronix Part No. 103-0015-00.

(13) Connector adapter. Fitted with two BNC plug connectors. Tektronix Part No. 103-0029-00.

(14) BNC to binding post adapter. Binding post accepts a banana plug. Tektronix Part No. 103-0033-00.

(15) BNC dual-input connector. Provides matched signal paths to both Type 1A7 input connectors. Tektronix Part No. 067-0525-00.

(16) BNC clip lead adapter. Tektronix Part No. 013-0076-00.

¹Referred to as oscilloscope in the procedure.

²Referred to as test oscilloscope in the procedure.

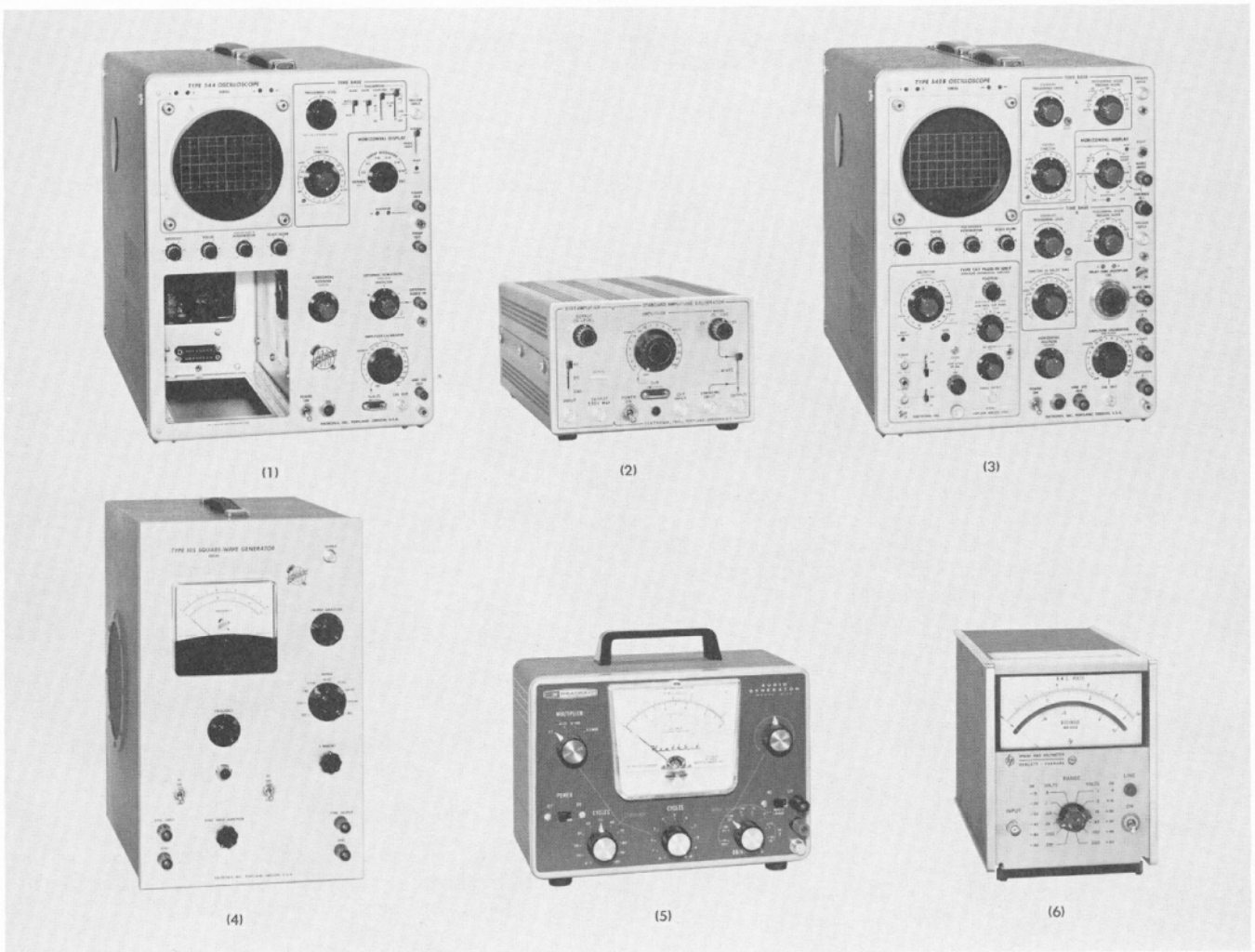

Fig. 6-1. Equipment required to calibrate the Type 1A7.

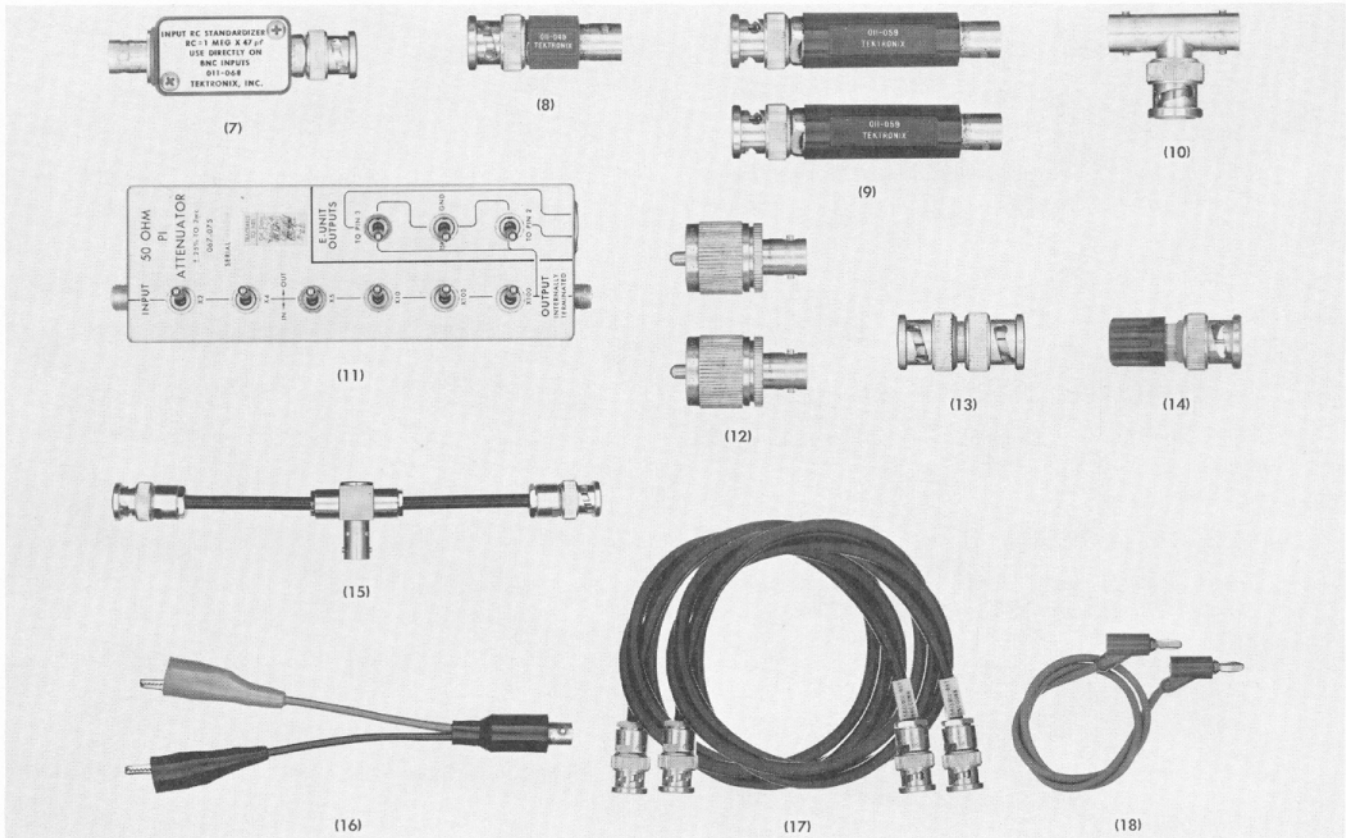

Fig. 6-2. Accessories used in the procedure.

(17) Two 50-ohm (nominal impedance) coaxial cables, 42 inches long, with a BNC plug connector on each end. Tektronix Part No. 012-0057-00.

(18) Patch cord, 18 inches long, equipped with a banana plug and jack combination connector on each end. Tektronix Part No. 012-0031-00.

(19) Dc offset divider. Two resistors are needed. Accuracy is dependent on the tolerance of the resistors; preferably, use 1% resistors as follows (see Fig. 6-3):

Resistor, fixed, 499 k, 1/2 W, 1%, Part No. 323-0452-00.

Resistor, fixed, 1.5 k, 1/2 W, 1%, Part No. 323-0210-00.

(20) Adjustment tools (one each, see Fig. 6-4):

a. Small screwdriver with a 1/8-inch wide tip to fit the small screwdriver-adjust potentiometers.

b. Insulated low-capacitance screwdriver, Jaco No. 125, 1 1/2-inch shank, 1/8-inch wide metal tip. Tektronix Part No. 003-0000-00.

c. Plastic rod, 5 inches long, 1/8-inch shank diameter, screwdriver shaped tip on one end. Tektronix Part No. 003-0301-00.

CALIBRATION RECORD AND INDEX

Tektronix Type 1A7

Serial No. _____

- 1. Adjust STEP ATTEN DC BAL COARSE (R500). Page 6-6.
To position trace on screen at 20 μ V/cm.
- 2. Adjust AC ATTEN BAL (R325). Page 6-6.
For no trace shift as VOLTS/CM switch is set from 10 mVOLTS to 10 μ VOLTS.
- 3. Adjust VERT POS RANGE (R380). Page 6-6.
To center the trace at 10 mV/cm.
- 4. Adjust GAIN (R308). Page 6-8.
For 5-cm deflection at 10 mV/cm with 50 mV applied.
- 5. Check VARIABLE Control Ratio. Page 6-9.
Ratio of 2.5:1 or better.
- 6. Adjust +GRID CURRENT (R115). Page 6-10.
For no trace shift as +INPUT coupling switch is set from GND to AC at 200 μ V/cm.

Calibration—Type 1A7

- 7. Adjust —GRID CURRENT (R215). Page 6-10.
For no trace shift as —INPUT coupling switch is set from GND to AC at 200 μ V/cm.
- 8. Adjust DC SHIFT (R190). Page 6-11.
For quick return of trace with 300 mV dc applied to +INPUT at 1 mV/cm.
- 9. Check total dc offset range. Page 6-11.
300 mV (+11%, —10%).
- 10. Check INPUT OVERLOAD Neon. Page 6-12.
Lights when 0.3-v dc applied at 10 mV/cm; turns off when a 0.1-V calibrator signal is applied.
- 11. Adjust C221—Cross Neutralization. Page 6-12.
Drive +INPUT with 50-mV signal at 10 mV/cm. Switch —INPUT from GND to DC. \leq 3% aberration.
- 12. Adjust C121—Cross Neutralization. Page 6-13.
Drive —INPUT from 50-mV signal at 10 mV/cm. Switch +INPUT from GND to DC. \leq 3% aberration.
- 13. Adjust C111— $\times 1$ +Input Attenuator Time Constant Standardization. Page 6-14.
Optimum square-wave response at 10 mV/cm.
- 14. Adjust C211— $\times 1$ —Input Attenuator Time Constant Standardization. Page 6-15.
Optimum square-wave response at 10 mV/cm.
- 15. Adjust 10 μ V GAIN (R345). Page 6-16.
For 5-cm deflection at 10 μ V/cm with 50 μ V applied.
- 16. Check VOLTS/CM Gain Switching. Page 6-17.
For deflection accuracy from 10 μ V/cm to 10 mV/cm.
- 17. Adjust DC COMMON MODE BALANCE R175. Page 6-18.
For best CMRR at 100 μ V/cm with 20-V peak to peak 100-Hz sine waves dc coupled to the Type 1A7.
- 18. Adjust C143 and C144. Page 6-19.
For best CMRR at 100 μ V/cm with 20-V peak to peak 100-kHz sine waves dc coupled to the Type 1A7.
- 19. Check Ac Coupled CMRR at 60 Hz. Page 6-20.
 \geq 2000:1.
- 20. Check Input Attenuator Accuracy. Page 6-21.
For $\pm 2\%$ accuracy at deflection factors from 20 mV/cm to 10 V/cm (see Table 6-2).
- 21. Adjust Attenuator Differential Balance. Page 6-23.
Adjust so the —Input attenuator dc attenuation matches the +Input.
- 22. Adjust +Input Attenuator Compensation. Page 6-23.
For optimum square-wave response according to Table 6-4.
- 23. Adjust —Input Series Compensation to Match +Input. Page 6-24.
For best common-mode rejection (see Table 6-5).
- 24. Adjust —Input Attenuator Shunt Compensation. Page 6-25.
For optimum square-wave response (see Table 6-6).
- 25. Check Risetime. Page 6-26.
Between 0.584 and 0.875 μ s at 10 mV/cm.
- 26. Check HIGH FREQ 3 dB POINT Switch. Page 6-28.
All positions for roll off in square-wave response.
- 27. Check LOW FREQ 3 dB POINT Switch. Page 6-29.
All positions for decay in square-wave response.
- 28. Adjust SIGNAL OUTPUT DC LEVEL (R490). Page 6-31.
For zero at SIGNAL OUTPUT connector with trace centered.
- 29. Check SIGNAL OUTPUT Gain. Page 6-32.
For 170 mV, $\pm 10\%$, with 5 cm of deflection on crt.
- 30. Adjust C493—SIGNAL OUTPUT Divider Compensation. Page 6-33.
For best square-wave response.
- 31. Check Noise. Page 6-33.
10.2 mV RMS or less at SIGNAL OUTPUT connector.

Calibration Engineer _____

Date _____

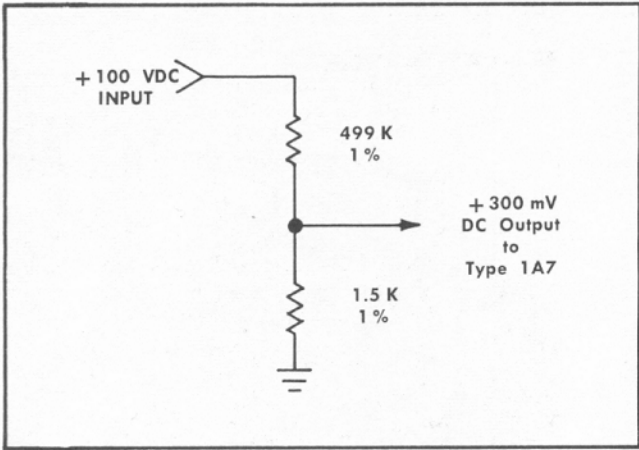

Fig. 6-3. Dc offset divider. No construction is required since the resistors are connected to the binding posts on the Type 1A7 (see Fig. 6-14 in the procedure).

PRELIMINARY PROCEDURE

1. Remove the left side panel from the oscilloscope.
2. Insert the Type 1A7 into the oscilloscope plug-in compartment.
3. Connect the oscilloscope power cord to the design-center (115- or 230-volt) operating voltage for which the oscilloscope is wired.
4. Turn on the oscilloscope and allow 20 minutes for warm up and stabilization.
5. Preset the Type 1A7 front-panel controls to these settings:

VOLTS/CM	10 mVOLTS
VARIABLE	Fully counterclockwise
POSITION	Midrange
HIGH FREQ 3 dB POINT	500 kHz
LOW FREQ 3 dB POINT	DC
AC-GND-DC (+INPUT)	GND
AC-GND-DC (-INPUT)	GND

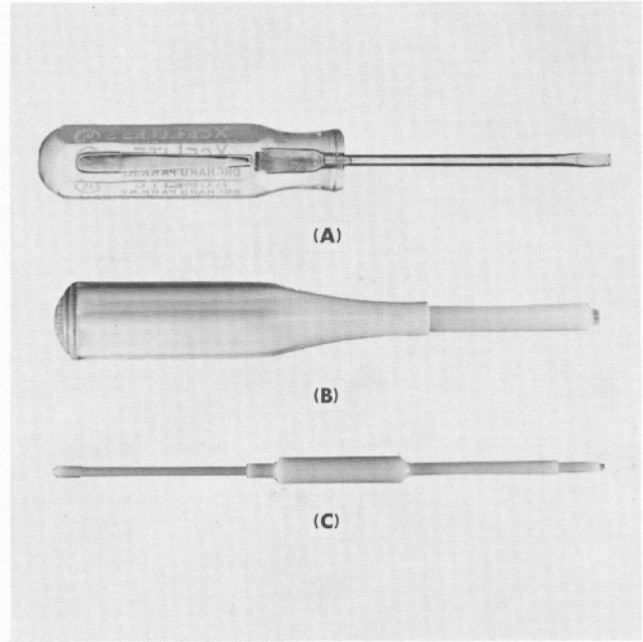

Fig. 6-4. Adjustment tools.

STEP ATTEN DC BAL FINE	Midrange
DC OFFSET ON-OFF	OFF ³
DC OFFSET (Coarse)	Midrange
DC OFFSET FINE	Midrange

6. Preset the oscilloscope front-panel controls as follows:

Time/Cm	.5 mSec
Variable (Time/Cm)	Calibrated
Triggering	+Int, AC, Auto

³When the DC OFFSET ON-OFF switch is set to OFF in subsequent listings of the Type 1A7 control settings, the DC OFFSET (Coarse) and DC OFFSET FINE controls are not included, but it is intended that they be at the midrange position unless stated otherwise.

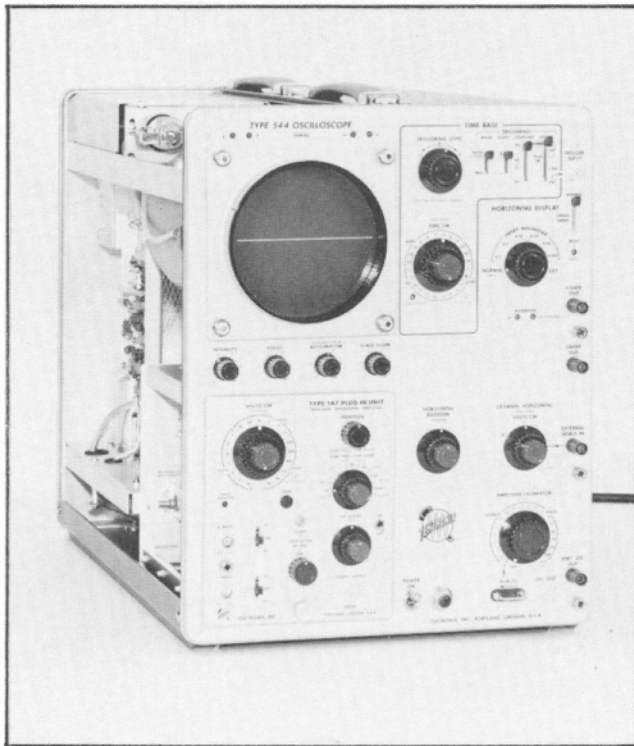

Fig. 6-5. Initial setup, step 1a.

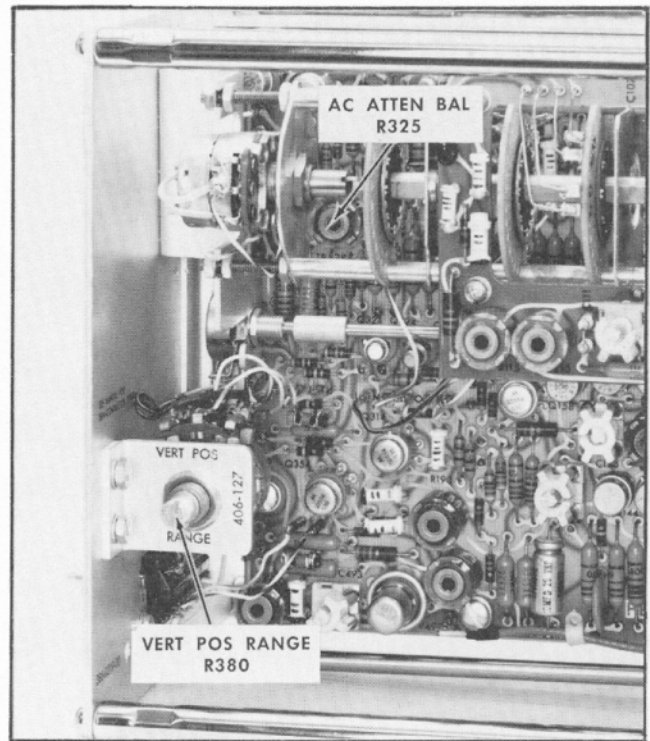

Fig. 6-6. Location of the AC ATTEN BAL R325 (steps 1 and 2) and the VERT POS RANGE R380 (steps 1 and 3) adjustments.

CHECK AND ADJUSTMENT PROCEDURE

1. Adjust STEP ATTEN DC BAL COARSE (R500) ①

- a. Initial setup is shown in Fig. 6-5.
- b. Preset the AC ATTEN BAL (R325) and VERT POS RANGE (R380) adjustments (see Fig. 6-6) to midrange if it is suspected that these controls are not in proper adjustment.
- c. Adjust the STEP ATTEN DC BAL COARSE control (see Fig. 6-7) so the trace is positioned to graticule center.

NOTE

The STEP ATTEN DC BAL COARSE adjustment is a 40-turn control that has no mechanical stops. This control differentially changes the heater voltage of V124, V134, V224 and V234. When adjusting this control, allow time for the trace to stabilize as the heaters and cathodes reach their operating temperature.

d. Rotate the VARIABLE control to the CALIBRATED position and slowly readjust the STEP ATTEN DC BAL COARSE control so the trace is positioned to graticule center.

e. Set the VOLTS/CM switch to 20 μ VOLTS. The adjustment is set with sufficient accuracy if the trace is on screen when the VOLTS/CM switch is set to 20 μ VOLTS. Readjust if necessary by starting from the VOLTS/CM position where the trace is on the screen and working down to the 20 μ VOLTS position so the end result is an on-screen trace at 20 μ VOLTS.

NOTE

If adjustment range is insufficient, switching tubes within one heat sink is a good solution. For example, switch V124 and V224.

2. Adjust AC ATTEN BAL (R325) ①

- a. Set the Type 1A7 controls as follows:

VOLTS/CM	10 mVOLTS
LOW FREQ 3 dB POINT	10 kHz
HIGH FREQ 3 dB POINT	100 Hz
- b. Note the position of the trace for reference.
- c. Rotate the VOLTS/CM switch from the 10 mVOLTS position to 10 μ VOLTS. If there is a trace shift, leave the VOLTS/CM switch in the 10 μ VOLTS position and adjust the AC ATTEN BAL control (R325, see Fig. 6-6) so the trace is positioned to the same point as noted in step b.
- d. Interaction: Set the HIGH FREQ 3 dB POINT switch to 500 kHz and the LOW FREQ 3 dB POINT switch to DC. Repeat step 1e.

3. Adjust VERT POS RANGE (R380) ①

- a. Set the Type 1A7 controls as follows:

VOLTS/CM	10 mVOLTS
VARIABLE	CALIBRATED

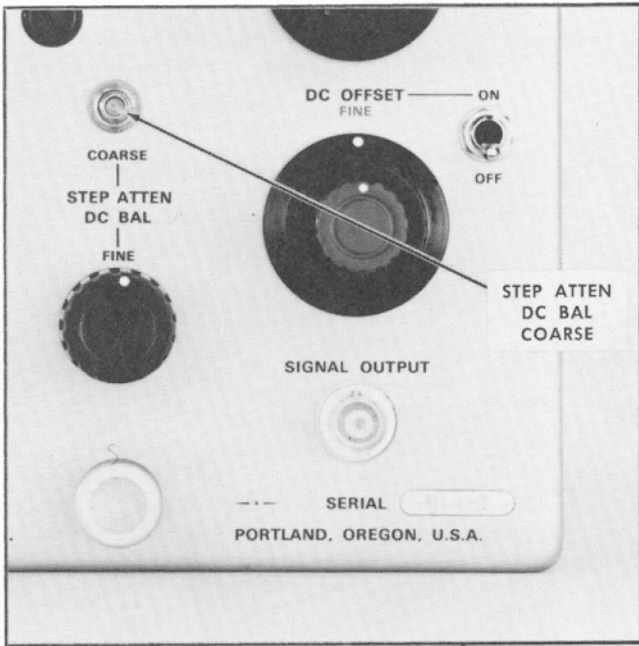

Fig. 6-7. Location of step 1 adjustment.

b. Check the position of these controls:

POSITION	Midrange
LOW FREQ 3 dB POINT	10 kHz
HIGH FREQ 3 dB POINT	100 Hz
STEP ATTEN DC BAL FINE	Midrange

c. Check that the trace coincides with graticule center. If it does not, adjust the VERT POS RANGE control (R380, see Fig. 6-6) to center the trace.

NOTE

If the trace shifts considerably as the VOLTS/CM switch is rotated from one position to another when performing the remaining steps in this calibration procedure, adjust the front-panel STEP ATTEN DC BAL FINE control to minimize the trace shift. Exception: When using the higher sensitivities (100 μ VOLTS to 10 μ VOLTS), the POSITION control can be set to midrange and the STEP ATTEN DC BAL FINE control can be used as a positioning control, if desired.

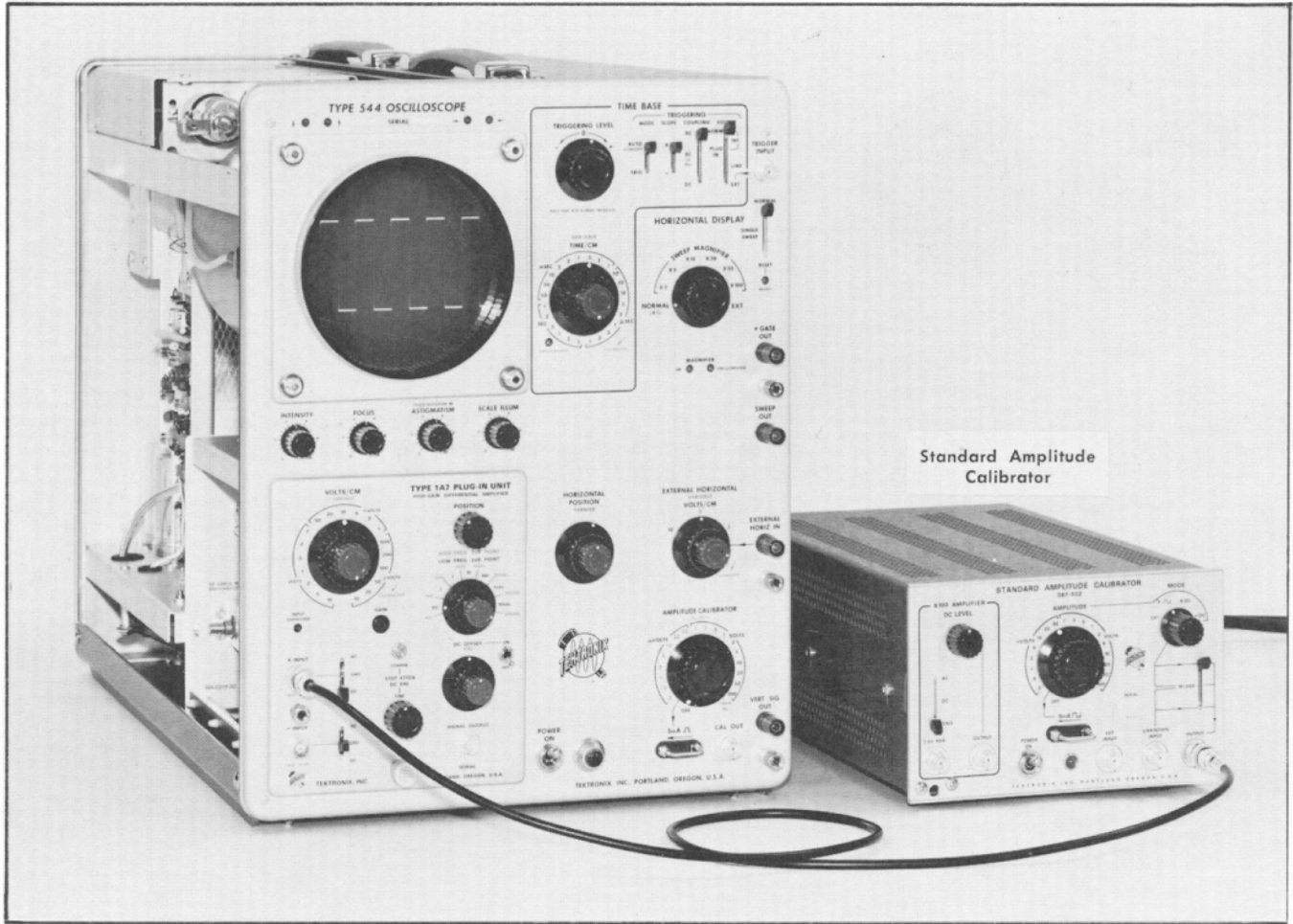

Fig. 6-8. Setup at completion of step 4b.

4. Adjust GAIN (R308)

a. Set the Type 1A7 controls as follows:

- +INPUT AC-GND-DC DC
- HIGH FREQ 3 dB POINT 500 kHz
- LOW FREQ 3 dB POINT DC

At this point in the procedure, the remaining controls should be at the following positions:

Type 1A7

- VOLTS/CM 10 mVOLTS
- VARIABLE CALIBRATED
- POSITION Midrange
- AC-GND-DC (—INPUT) GND
- STEP ATTEN DC BAL Adjusted for proper dc
- FINE balance (see step 3
- NOTE)
- DC OFFSET ON-OFF OFF

Oscilloscope

- Time/Cm .5 mSec
- Variable (Time/Cm) Calibrated
- Triggering +Int, AC, Auto

①

b. Apply a 50 mV peak-to-peak square-wave signal from a standard amplitude calibrator through a coaxial cable to the +INPUT connector. Fig. 6-8 shows the setup.

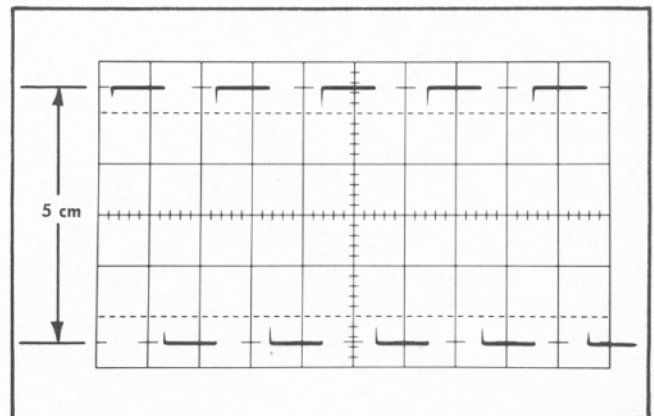

Fig. 6-9. Typical crt display showing correct gain adjustment. Vertical deflection factor: 10 mV/cm.

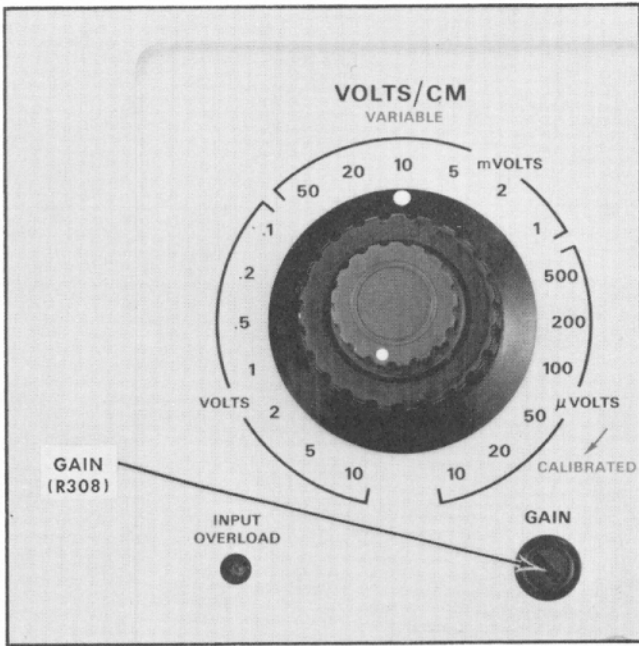

Fig. 6-10. Location of step 4 adjustment.

- c. Using the POSITION control, align the display with the graticule lines.
- d. Check the display for a vertical amplitude of exactly 5 cm (see Fig. 6-9). If it is not, adjust the GAIN control (R308), see Fig. 6-10) to obtain the proper amplitude display.

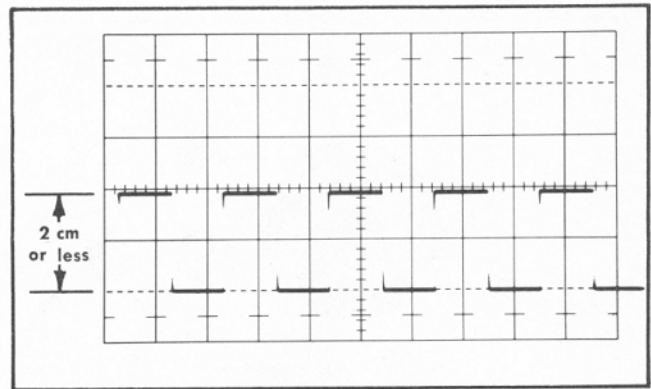

Fig. 6-11. Checking the VARIABLE control 2.5:1 ratio. This display is within the 2-cm amplitude requirement.

5. Check VARIABLE Control Ratio

- a. Rotate the VARIABLE control to its fully counterclockwise position.
- b. Check the vertical amplitude of the display. The display amplitude should be 2 cm or less (see Fig. 6-11) to meet the 2.5:1-or-better ratio requirement.
- c. Reset the VARIABLE control to the CALIBRATED position.
- d. Disconnect the calibrator signal.

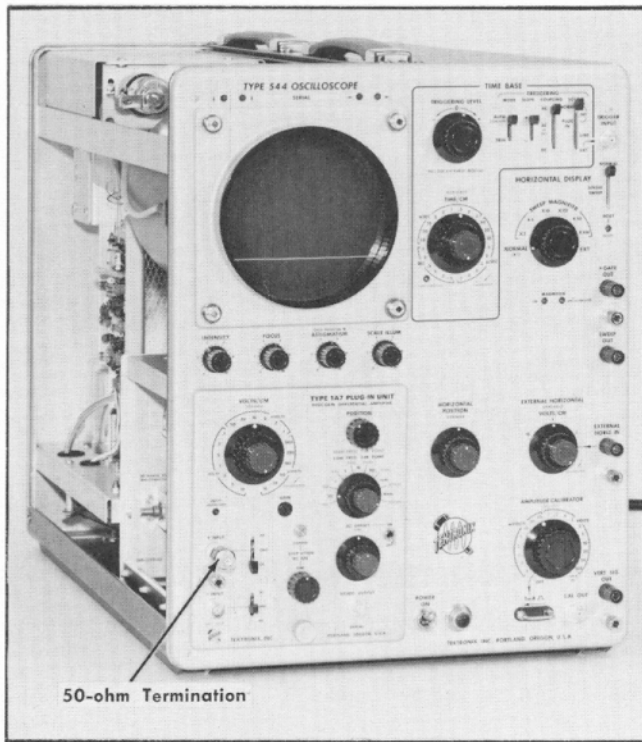

Fig. 6-12. Setup at completion of step 6a.

6. Adjust +GRID CURRENT (R115) ①

a. Connect a 50-ohm termination to the +INPUT connector. See Fig. 6-12 for setup.

b. Set the Type 1A7 controls as follows:

VOLTS/CM	200 μ VOLTS
AC-GND-DC (+INPUT)	GND

Up to this point in the procedure, the remaining controls should be at the following positions:

Type 1A7

VARIABLE	CALIBRATED
POSITION	Near midrange
HIGH FREQ 3 dB POINT	500 kHz
LOW FREQ 3 dB POINT	DC
AC-GND-DC (-INPUT)	GND
STEP ATTEN DC BAL FINE	Adjusted for proper dc balance (see step 3 NOTE)
DC OFFSET ON-OFF	OFF

Oscilloscope

Time/Cm	.5 mSec
---------	---------

Variable (Time/Cm)	Calibrated
Triggering	+Int, AC, Auto

c. Using the POSITION control, position the trace to coincide with graticule center. This is the reference point for the trace.

d. Set the +INPUT AC-GND-DC switch to AC. If there is a trace shift, adjust the +GRID CURRENT control (R115; see Fig. 6-13) so the trace is positioned to graticule center. To check if the adjustment is made accurately, set the +INPUT AC-GND-DC switch to GND and back to AC. There should be no trace shift.

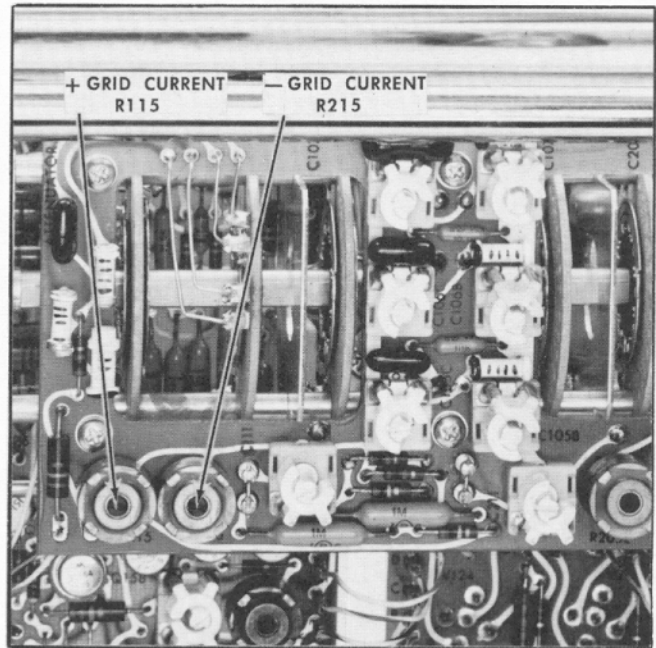

Fig. 6-13. Location of adjustments for steps 6 and 7.

7. Adjust -GRID CURRENT (R215) ①

a. Remove the 50-ohm termination from the +INPUT connector and connect it to the -INPUT connector. (This setup is similar to Fig. 6-12 except the termination is now connected to the -INPUT connector.)

b. Set the +INPUT AC-GND-DC switch to GND.

c. Check that the trace coincides with graticule center as the reference.

d. Set the -INPUT AC-GND-DC switch to AC. If there is a trace shift, adjust the -GRID CURRENT control (R215; see Fig. 6-13) so the trace is positioned to graticule center. To check on the adjustment, set the -INPUT AC-GND-DC switch to GND and back to AC. There should be no trace shift.

e. Disconnect the 50-ohm termination.

8. Adjust DC SHIFT (R190)



a. Set the Type 1A7 controls as follows:

VOLTS/CM	1 mVOLTS
AC-GND-DC (-INPUT)	GND

b. Set the oscilloscope Time/Cm switch to 1 mSec. Up to this point in the procedure, the remaining controls should be set as follows:

Type 1A7

VARIABLE	CALIBRATED
POSITION	Midrange
HIGH FREQ 3 dB POINT	500 kHz
LOW FREQ 3 dB POINT	DC
AC-GND-DC (+INPUT)	GND
STEP ATTEN DC BAL FINE	Adjust for proper dc balance (see step 3 NOTE)
DC OFFSET ON-OFF	OFF

Oscilloscope

Variable (Time/Cm)	Calibrated
Triggering	+Int, AC, Auto

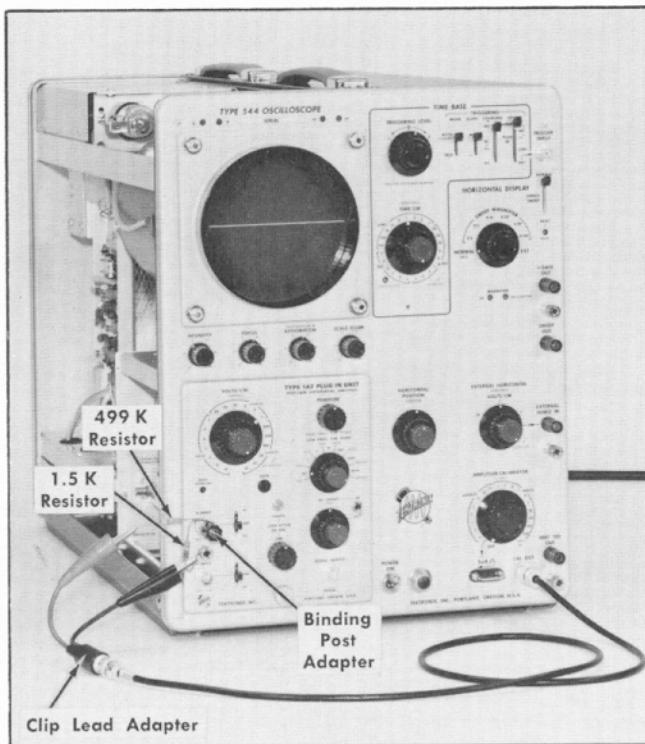

Fig. 6-14. Setup at completion of step 8e. Resistors used in this setup have tolerance of 1%.

c. Connect a binding post adapter (item 14) to the +INPUT connector.

d. Connect the resistors (item 19) to the +INPUT connector and Gnd on the Type 1A7. Use Figs. 6-3 and 6-14 as a guide for this setup.

e. Apply +100 Vdc from the oscilloscope calibrator to the divider (see Figs. 6-3 and 6-14).

f. Using the POSITION control, position the trace to graticule center as a reference point.

g. Set the +INPUT AC-GND-DC switch to the DC position for 20 seconds and then switch back to GND. Check that the trace returns quickly within ± 1 cm of graticule center. Within 20 seconds after the switch has been set to GND, check that the trace has not deviated more than 2.5 cm from graticule center. If the trace does not return to center screen within the limits described, adjust the DC SHIFT control (R190; see Fig. 6-15) to obtain the desired results.

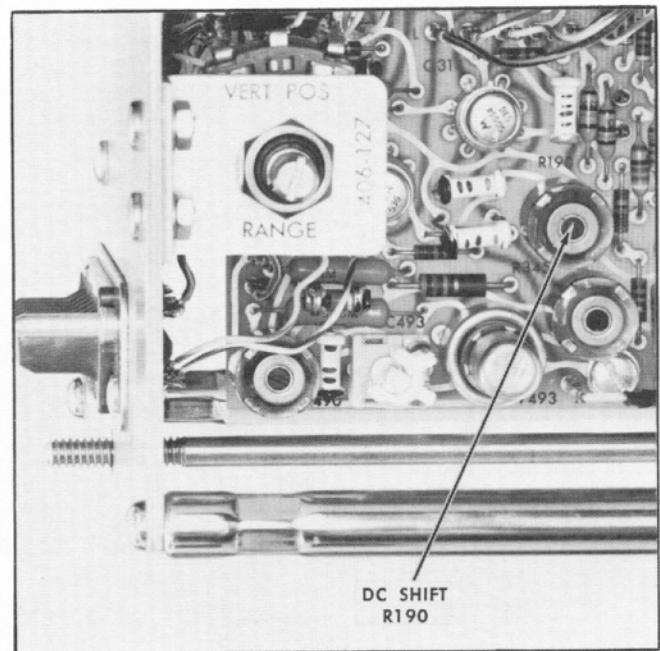

Fig. 6-15. Location of step 8 adjustment.

h. To check if the adjustment is set properly, repeat steps f and g.

i. Interaction: If the DC SHIFT control (R190) was moved from its former position, repeat step 4.

9. Check Total Dc Offset Range

a. Using the same procedure and setup (see Fig. 6-14) as described in steps 8b through 8f, set the Type 1A7 controls as follows:

VOLTS/CM	10 mVOLTS
DC OFFSET (Coarse)	Fully counterclockwise
DC OFFSET FINE	Fully counterclockwise

b. Check that the +INPUT AC-GND-DC switch is set to GND and the trace is positioned to graticule center for reference.

c. Set these controls simultaneously:

AC-GND-DC (+INPUT)	DC
DC OFFSET ON-OFF	ON

Calibration—Type 1A7

d. Check that the trace returns within +3.3 cm (+33 mV) or -3 cm (-30 mV) with respect to graticule center. Full range of the DC OFFSET controls is 300 mV; +11%, -10%. For example, +11% of 300 mV is a maximum tolerance of +33 mV or +3.3 cm trace deviation with respect to zero reference.

e. Set the Type 1A7 controls as follows:

AC-GND-DC (+INPUT)	GND
DC OFFSET ON-OFF	OFF
DC OFFSET (Coarse)	Fully clockwise
DC OFFSET FINE	Fully clockwise

f. Turn off the calibrator. Connect the divider resistors and connector adapter to the -INPUT connector. Reset the calibrator for +100 Vdc output.

g. Check that the trace coincides with graticule center.

h. Set these controls simultaneously:

AC-GND-DC (-INPUT)	DC
DC OFFSET ON-OFF	ON

i. Check that the trace returns within -3.3 cm or +3 cm with respect to graticule center.

10. Check INPUT OVERLOAD Neon

a. Continuing from the previous step (9i) and using the same setup, set the Type 1A7 controls as follows:

DC OFFSET ON-OFF	OFF
DC OFFSET (Coarse)	Midrange
DC OFFSET FINE	Midrange

b. Check that the VOLTS/CM switch is set to 10 mVOLTS and the INPUT OVERLOAD neon is turned on.

c. Set the oscilloscope calibrator for 0.1-volt square-wave output.

d. Remove the clip lead adapter, resistors and binding post adapter. Connect the coaxial cable directly to the -INPUT connector.

e. Check that the INPUT OVERLOAD neon is extinguished.

11. Adjust C221—Cross Neutralization ①

a. Set the oscilloscope Time/Cm switch to 0.5 mSec.

b. Set the Type 1A7 controls as follows:

AC-GND-DC (+INPUT)	DC
AC-GND-DC (-INPUT)	GND

Up to this point in the procedure, the remaining controls should be at the following positions:

Type 1A7

VOLTS/CM	10 mVOLTS
VARIABLE	CALIBRATED
POSITION	Midrange
HIGH FREQ 3 dB POINT	500 kHz
LOW FREQ 3 dB POINT	DC
STEP ATTEN DC BAL FINE	Adjusted for proper dc balance (see step 3 NOTE)
DC OFFSET ON-OFF	OFF

Oscilloscope

Variable (Time/Cm)	Calibrated
Triggering	+Int, AC, Auto

c. Set the oscilloscope calibrator for a 50-mV output. Disconnect the calibrator signal from the -INPUT connector and apply it to the +INPUT connector. Fig. 6-16 shows the setup.

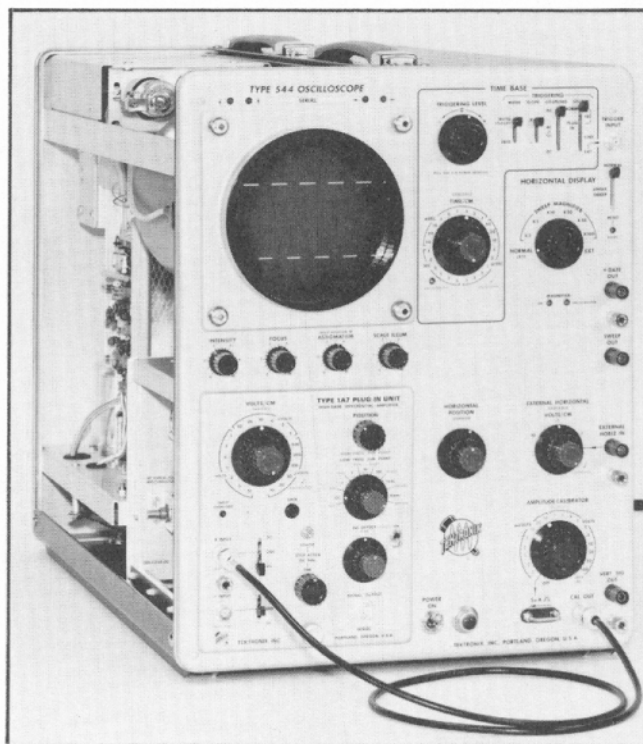

Fig. 6-16. Setup at completion of step 11c.

NOTE

From this point on in the procedure, the Type 1A7 POSITION and the oscilloscope horizontal positioning controls may not always be mentioned. Use these controls whenever it is necessary to position the display for best viewing.

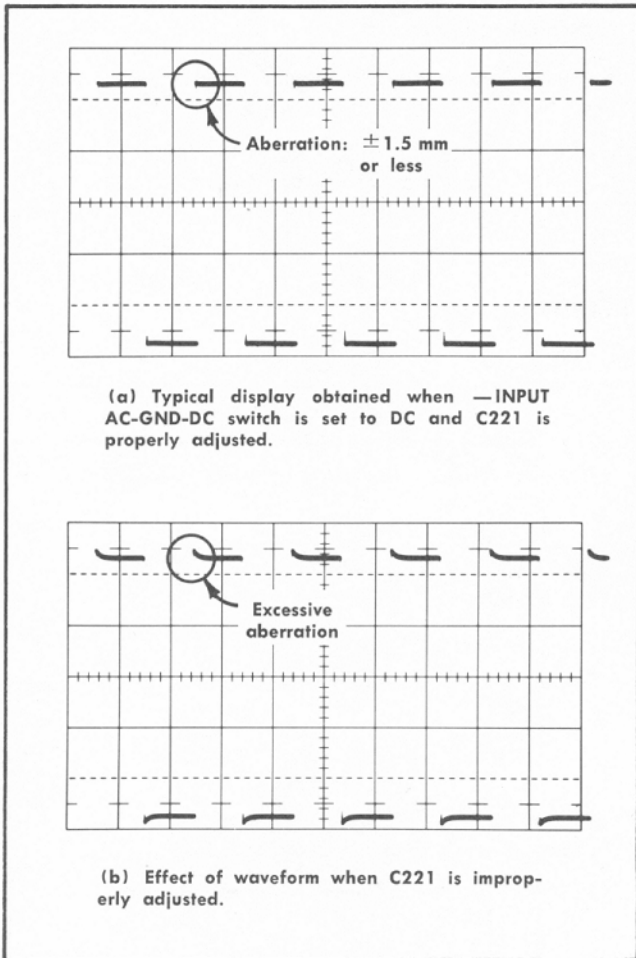

Fig. 6-17. Adjusting for minimum crosstalk between inputs. Vertical deflection factor: 10 mV/cm; sweep rate: 0.5 msec/cm.

d. Set the —INPUT AC-GND-DC switch to DC. Observe the upper leading corner of the waveform. It should appear similar to the display shown in Fig. 6-17a. Tolerance of the aberration should be no greater than $\pm 3\%$ (± 1.5 mm). If the corner aberration is excessive (see Fig. 6-17b), adjust C221 (see Fig. 6-18) for best square corner.

e. Interaction: C221 affects the $\times 1$ input capacitance and all other input attenuator adjustments. If C221 is adjusted

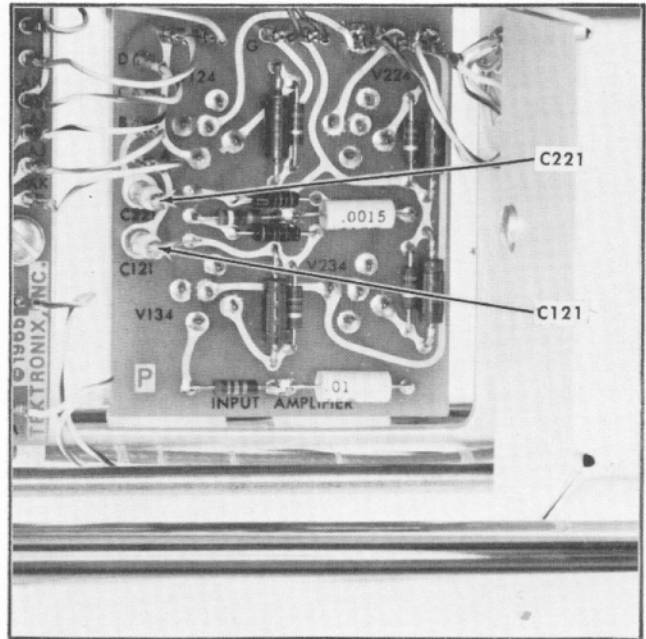

Fig. 6-18. Location of adjustments for steps 11 and 12.

out of sequence, steps 13, 14 and 21 through 23 must also be performed.

12. Adjust C121—Cross Neutralization ①

a. Disconnect the signal from the +INPUT connector and apply it to the —INPUT connector.

b. Set the +INPUT AC-GND-DC switch to GND and check that the —INPUT AC-GND-DC switch is set to DC.

c. Set the +INPUT AC-GND-DC switch to DC and observe the lower leading corner at the bottom of the second cycle on the display. The waveform should appear similar to the one obtained in step 11d and shown in Fig. 6-17a except the bottom corner is the point of interest. If the front-corner aberration is greater than $\pm 3\%$ (± 1.5 mm), adjust C121 (see Fig. 6-18) for best corner.

d. Interaction: C121 affects the $\times 1$ input capacitance and all other input attenuator adjustments. If C121 is adjusted out of sequence steps 13, 14 and 21 through 23 must also be performed.

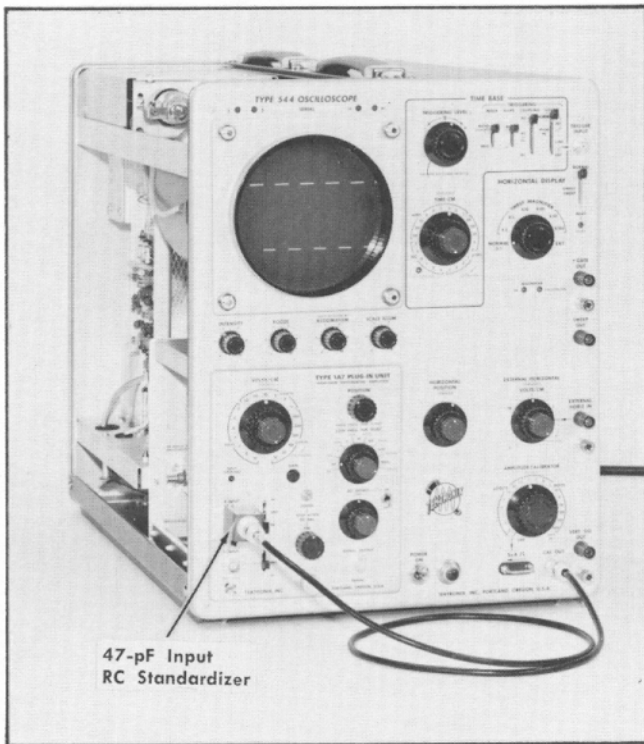

Fig. 6-19. Setup at completion of step 13c.

13. Adjust C111—X1 + Input Attenuator Time Constant Standardization

NOTE

It is important that C121 and C221 be properly adjusted before attempting this adjustment. If you have not performed steps 11 and 12, do so at this point.

a. Set the —INPUT AC-GND-DC switch to GND.

At this point in the procedure, the remaining controls should be at the following positions:

Type 1A7

VOLTS/CM	10 mVOLTS
VARIABLE	CALIBRATED
POSITION	Near midrange
HIGH FREQ 3 dB POINT	500 kHz
LOW FREQ 3 dB POINT	DC
AC-GND-DC (+INPUT)	DC
STEP ATTEN DC BAL	Adjusted for proper dc
FINE	balance (see step 3
	NOTE)
DC OFFSET ON-OFF	OFF

Oscilloscope

Time/Cm	.5 mSec
Variable (Time/Cm)	Calibrated
Triggering	+Int, AC, Auto

b. Connect a 47-pF input RC standardizer to the +INPUT connector.

c. Connect the coaxial cable to the standardizer. Fig. 6-19 shows the setup.

d. Set the oscilloscope calibrator for a 0.1-volt peak-to-peak output.

e. Check the square-wave display for flat tops (see Fig. 6-20a). If the tops are not flat (for example, see Fig. 6-20b or c), then adjust C111 (see Fig. 6-21) to obtain best square-wave response.

f. Interaction: If C111 is adjusted out of sequence, steps 14 and 21 through 24 must also be performed.

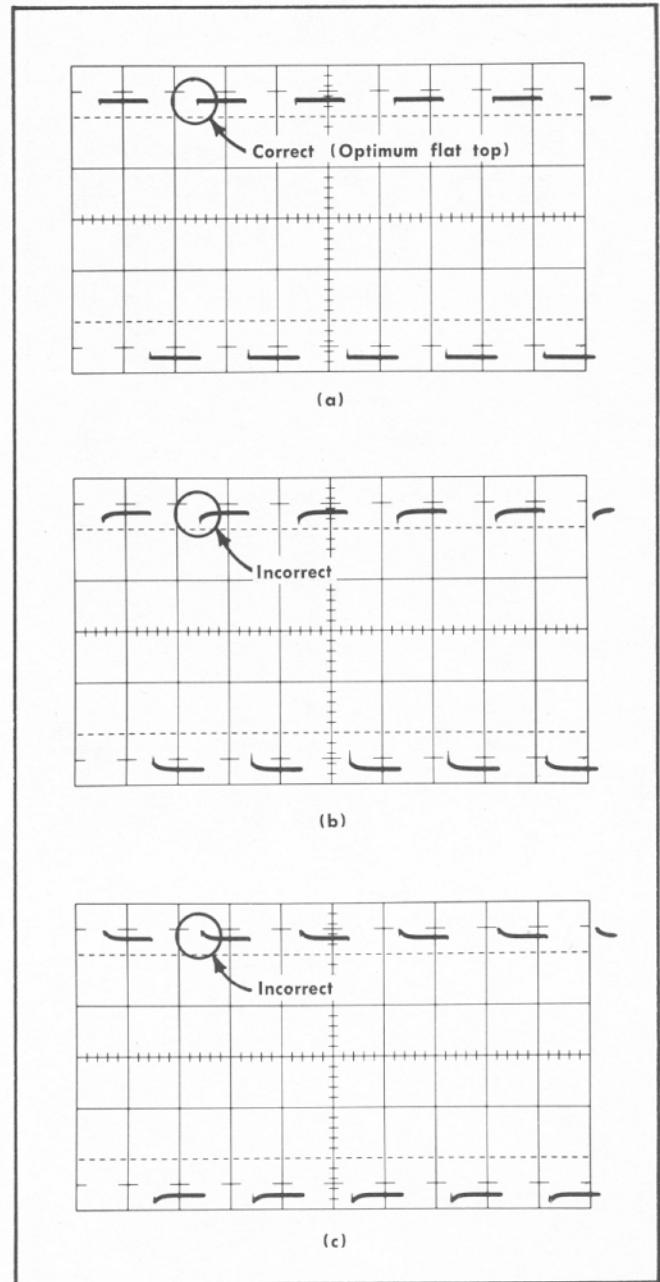

Fig. 6-20. Adjusting C111 to standardize the X1 +input attenuator time constant. Vertical deflection factor: 10 mV/cm; sweep rate: 0.5 msec/cm.

14. Adjust C211—X1 —Input Attenuator ① Time Constant Standardization

a. Disconnect the signal from the +INPUT connector and apply it to the —INPUT connector. (This setup is similar to Fig. 6-19 except, in this step, the signal is applied to the —INPUT connector.)

b. Set the Type 1A7 controls as follows:

AC-GND-DC (+INPUT) GND

AC-GND-DC (—INPUT) DC

c. The bottom of each square-wave cycle should be flat. If it is not, adjust C211 (see Fig. 6-21) for best flat-bottom square-wave display. Use Fig. 6-20a as a guide.

d. Interaction: If C211 is adjusted out of sequence, steps 13 and 21 through 24 must also be performed.

e. Disconnect the signal.

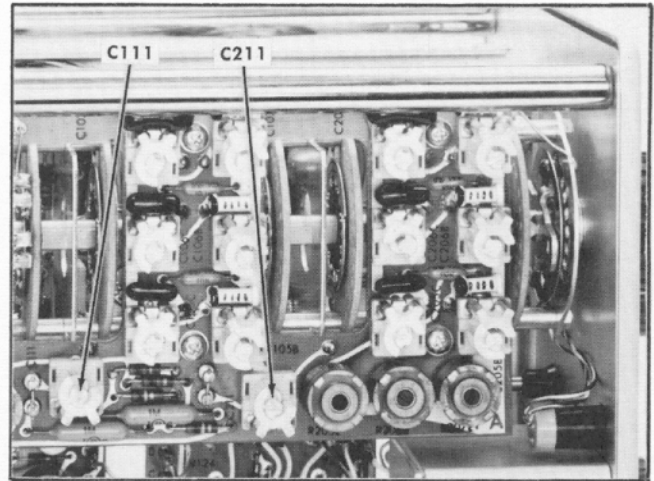

Fig. 6-21. Location of adjustments for steps 13 and 14.

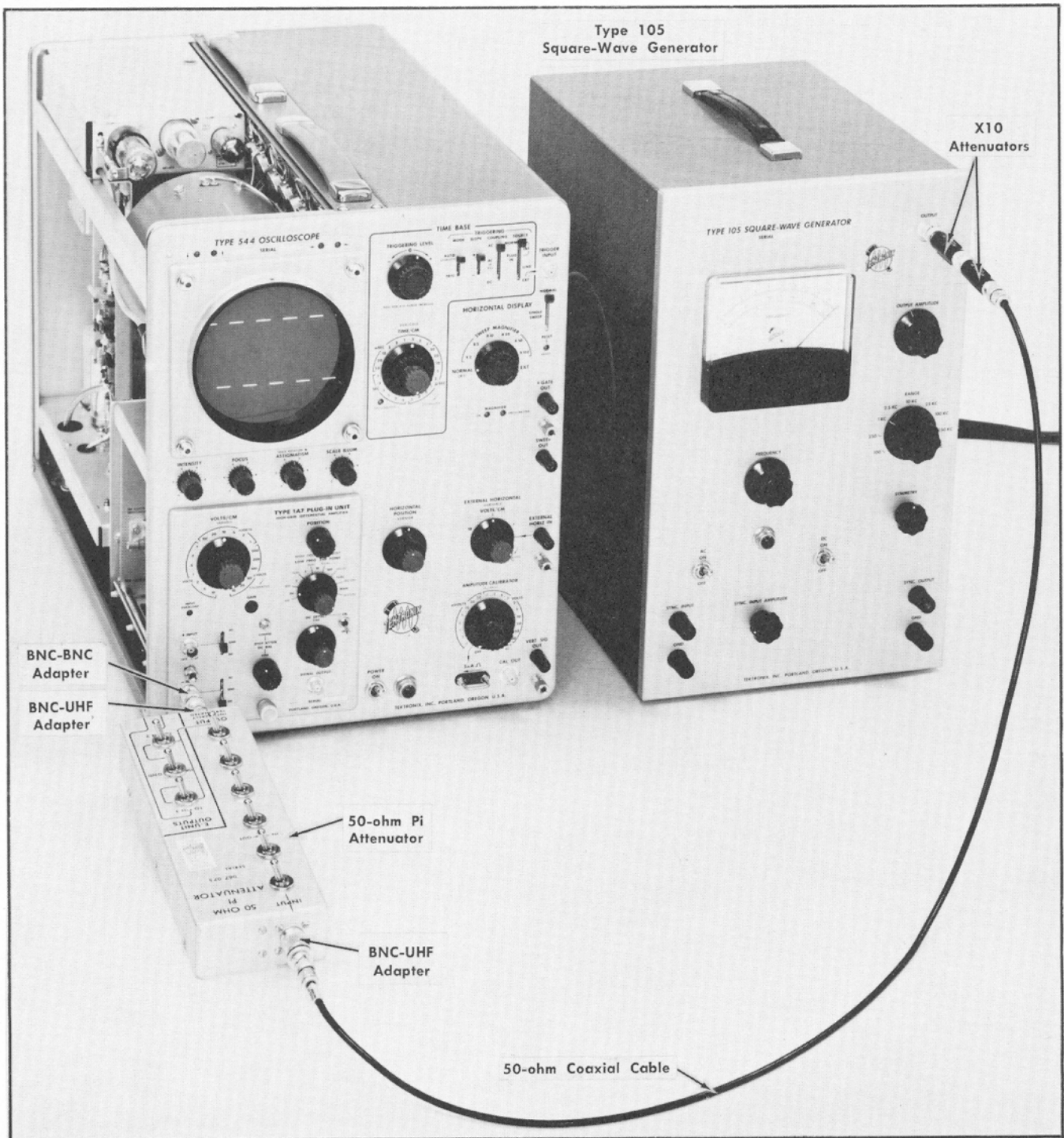

Fig. 6-22. Setup at completion of step 15c.

15. Adjust 10 μ V GAIN (R345)

a. At this point in the procedure, the controls should be at the following positions:

	Type 1A7
VOLTS/CM	10 mVOLTS
VARIABLE	CALIBRATED
POSITION	Near midrange



HIGH FREQ 3 dB POINT	500 kHz
LOW FREQ 3 dB POINT	DC
AC-GND-DC (+INPUT)	GND
AC-GND-DC (-INPUT)	DC
STEP ATTEN DC BAL	Adjusted for proper dc balance (see step 3 NOTE)
FINE	OFF
DC OFFSET ON-OFF	OFF

Oscilloscope

Time/Cm	.5 mSec
Variable (Time/Cm)	Calibrated
Triggering	+Int, AC, Auto

b. Apply a 1-kHz signal from the Type 105 through two 10× attenuators, coaxial cable, BNC-UHF adapter (item 12), 50-ohm Pi attenuator (item 11), BNC-UHF adapter (item 12), and a BNC-BNC adapter (item 13) to the —INPUT connector. Connect all devices in the order given. Fig. 6-22 shows the test setup.

c. Set all the 50-ohm Pi attenuator switches to the Out position (1× attenuation).

d. Adjust the Type 105 Output Amplitude control so the display is exactly 5 cm (50 mV) peak to peak (similar to Fig. 6-9). This is the reference amplitude.

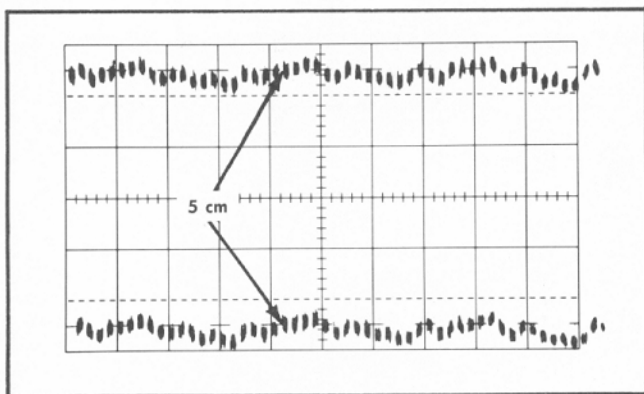

Fig. 6-23. Correct amplitude single-shot display obtained when the 10 μV GAIN control is adjusted properly. Vertical deflection factor: 10 μV/cm; sweep rate: 5 msec/cm.

e. Set the 50-ohm Pi attenuator ×100 and ×10 switches to the In position (1000×attenuation).

f. Set the Type 1A7 controls as follows:

VOLTS/CM	10 μVOLTS
HIGH FREQ 3 dB POINT	30 kHz

Set the oscilloscope controls as follows:

Triggering	+Line
Time/Cm	5 mSec

g. Check that the display amplitude is 5 cm. Measure the center-to-center amplitude of the display between the points shown in Fig. 6-23. If the display is not correct in amplitude, adjust the 10 μV GAIN control (R345; see Fig. 6-24).

NOTE

If excessive hum appears on the display, insert a 3- to 2-wire adapter in the Type 105 power cord to minimize ground-loop currents.

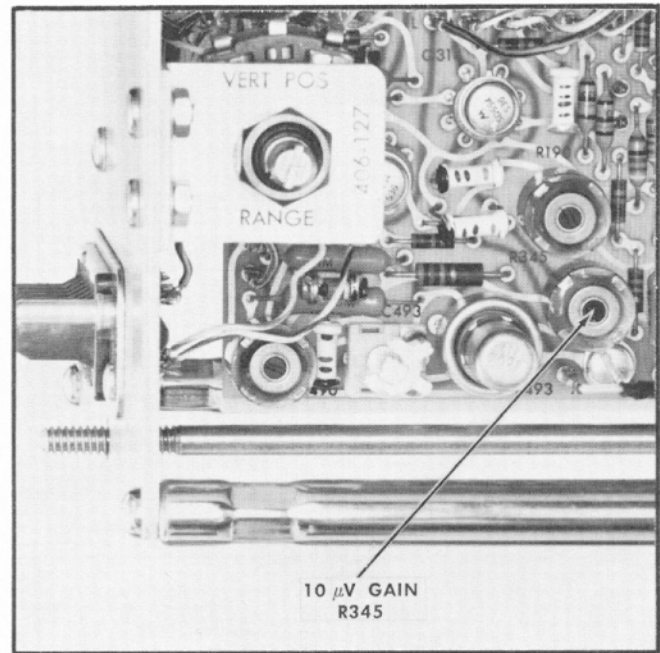

Fig. 6-24. Location of step 15 adjustment.

16. Check VOLTS/CM Gain Switching

a. After completing the previous step, use the same set-up to check the vertical deflection factors from 10 μV/cm to 10 mV/cm. Table 6-1 is provided as a guide. All amplitudes should be 5 cm peak to peak within the listed accuracies.

TABLE 6-1

VOLTS/CM Switch Position	50-ohm Pi Attenuator Switch Position	Deflection Accuracy
10 μVOLTS	In: ×100, ×10	Adjusted ⁴
20 μVOLTS	In: ×100, ×5	±2% or ±1 mm
50 μVOLTS	In: ×100, ×2	
100 μVOLTS	In: ×100	±1.5% or ±0.75 mm
200 μVOLTS ⁵	In: ×10, ×5	
500 μVOLTS	In: ×10, ×2	
1 mVOLTS	In: ×10	
2 mVOLTS	In: ×5	
5 mVOLTS	In: ×2	Reference
10 mVOLTS	In: None	

b. Disconnect the signal from the —INPUT connector.

⁴Adjusted for proper deflection factor as described in step 15g.

⁵For the remaining portion of this table (200 μVOLTS to 10 mVOLTS) set the oscilloscope Triggering controls to +Int and the Time/Cm switch to .5 mSec. Set the Type 1A7 HIGH FREQ 3 dB POINT switch to 500 kHz.

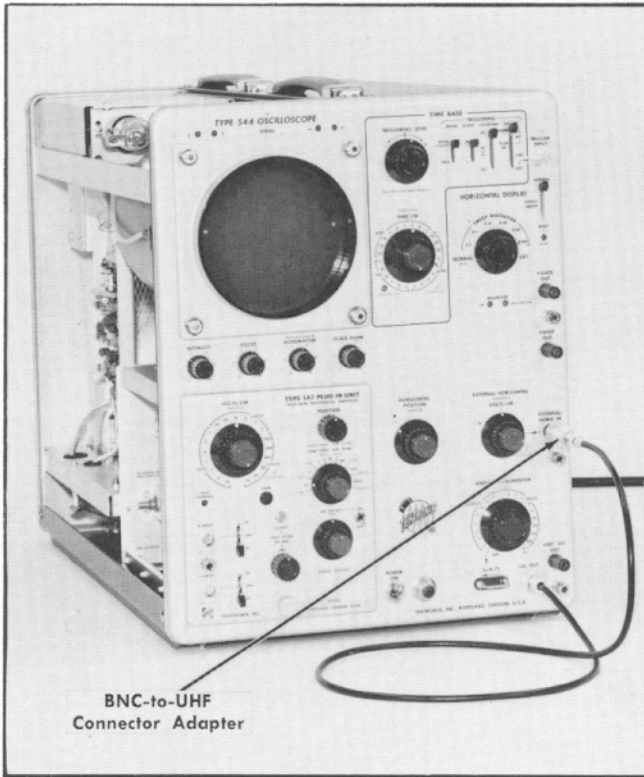

Fig. 6-25. Setup at completion of step 17c.

17. Adjust DC COMMON MODE BALANCE (R175)

- a. Set the —INPUT AC-GND-DC switch to GND.
- b. Set the oscilloscope controls as follows:

Horizontal Display	Ext
External Horizontal Volts/Cm	1

- c. Apply a 20-V peak-to-peak signal from the oscilloscope calibrator through a coaxial cable and a BNC-to-UHF connector adapter (item 12) to the oscilloscope Ext Horiz In connector. Fig. 6-25 shows the setup.
- d. Adjust the oscilloscope Variable External Horizontal Volts/Cm control so the horizontal deflection factor is 2 V/cm. The display should be two dots that are exactly 10 cm apart (see Fig. 6-26a).

NOTE

Leave the Variable External Horizontal Volts/Cm control at this setting until step 19 has been completed.

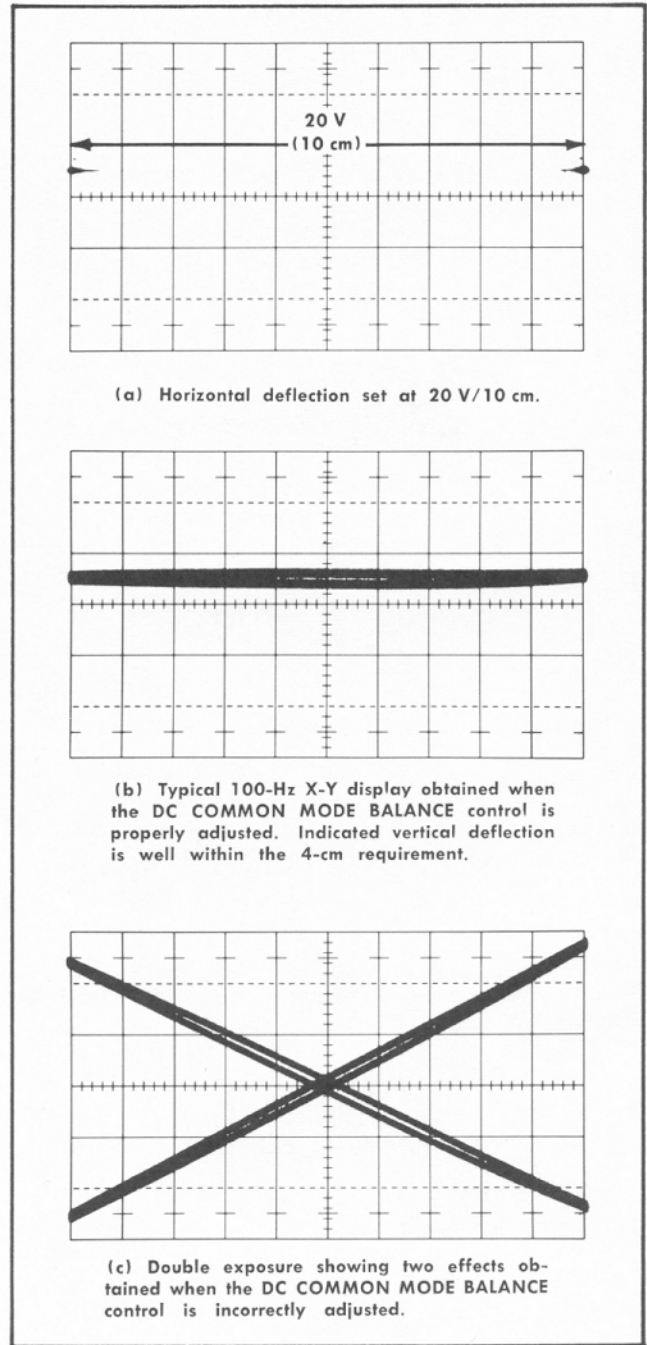

(a) Horizontal deflection set at 20 V/10 cm.

(b) Typical 100-Hz X-Y display obtained when the DC COMMON MODE BALANCE control is properly adjusted. Indicated vertical deflection is well within the 4-cm requirement.

(c) Double exposure showing two effects obtained when the DC COMMON MODE BALANCE control is incorrectly adjusted.

Fig. 6-26. Typical displays obtained when performing step 17.

- e. Disconnect the calibrator signal.
- f. Set the Type 1A7 VOLTS/CM switch to 100 μ VOLTS. At this point in the procedure, the remaining controls should be at the following positions:

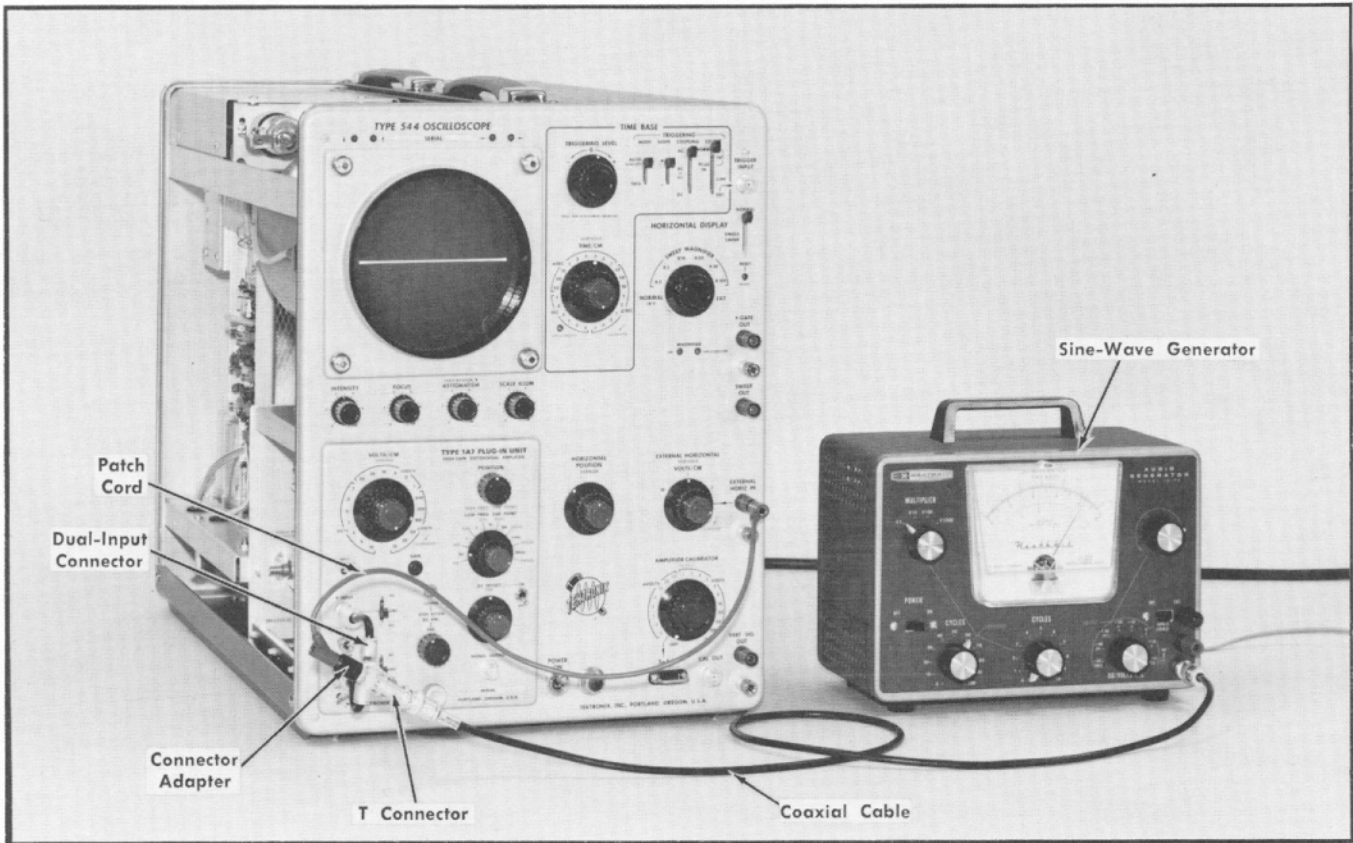

Fig. 6-27. Setup at completion of step 17g; used in steps 17g through 19d.

Type 1A7

VARIABLE POSITION	CALIBRATED
LOW FREQ 3 dB POINT	Near midrange
HIGH FREQ 3 dB POINT	DC
AC-GND-DC (+INPUT)	500 kHz
AC-GND-DC (-INPUT)	GND
STEP ATTEN DC BAL FINE	GND
DC OFFSET ON-OFF	Adjusted for proper dc balance (see step 3 NOTE)
	OFF

Oscilloscope

Time/Cm	.5 mSec
Variable (Time/Cm)	Calibrated
Triggering	+Int, AC, Auto

g. Apply a 100-Hz 20-V peak-to-peak signal from a sine-wave generator through a coaxial cable, T connector, and a dual-input connector to the two inputs on the Type 1A7. Use Fig. 6-27 as a guide for this setup.

h. Install a connector adapter on the T connector. Connect a patch cord from the adapter to the oscilloscope Ext Horiz In connector.

i. Set the sine-wave generator for an output of exactly 20 V, peak to peak. The horizontal deflection should be 10 cm.

j. Set the +INPUT and -INPUT AC-GND-DC switches simultaneously to DC.

k. Check the X-Y display for tilt. Vertical deflection of the tilt should not exceed 4 cm (see Fig. 6-26b). If excessive (see Fig. 6-26c for examples), adjust the DC COMMON MODE BALANCE control (R175; see Fig. 6-28) for minimum vertical deflection. The 4-cm requirement at 100 μ V/cm is equivalent to a CMRR of 50,000:1 ($4 \times 100 \mu\text{V} = 400 \mu\text{V}$; $20 \text{ V} \div 400 \mu\text{V} = 50,000$).

18. Adjust C143 and C144



a. Using the same equipment setup as that shown in Fig. 6-27, set the sine-wave generator for an output frequency of 100 kHz. Adjust the generator output so the horizontal deflection is exactly 10 cm (20 V).

b. Check the display. Tilt and vertical deflection should not exceed 4 cm overall (see Fig. 6-29). If excessive, adjust C143 and C144 (see Fig. 6-30) for minimum vertical deflection. These two adjustments interact. Adjustment C143 primarily affects the loop opening and C144 affects the loop tilt.

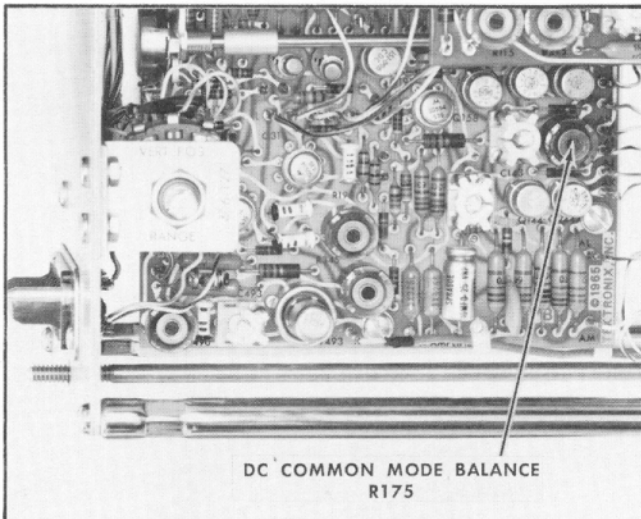

Fig. 6-28. Location of step 17 adjustment.

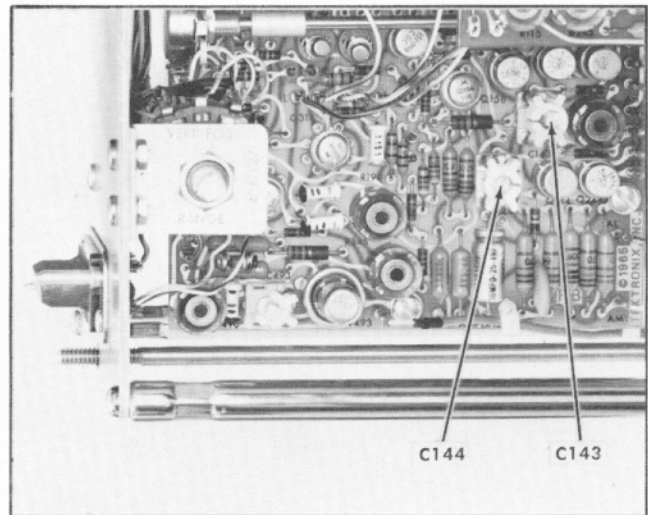

Fig. 6-30. Location of step 18 adjustments.

NOTE

If a higher CMRR is preferred over a range of dc to 20 kHz instead of dc to 100 kHz, set the generator for an output frequency of 20 kHz and an amplitude of 20 V. Adjust C143 and C144 so the

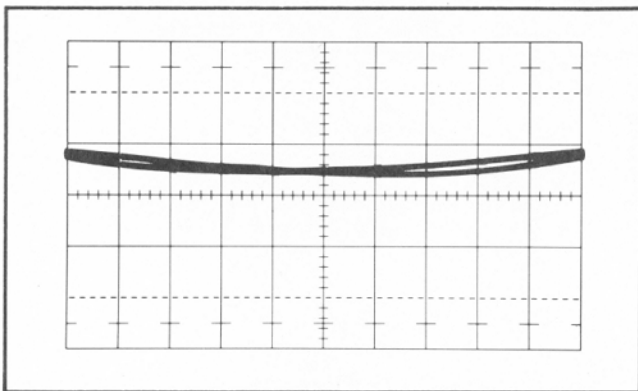

Fig. 6-29. Typical display obtained when C143 and C144 are adjusted properly at 100 kHz. Tilt and vertical deflection are within the 4-cm requirement.

vertical deflection is 0.65 cm or less. (This is equivalent to a CMRR of $\geq 310,000:1$.) For best results repeat step 17. Once these adjustments are made, do not change the dress of the leads connecting to terminals AD through AK on the Main Amplifier board.

19. Check Ac-Coupled CMRR at 60 Hz

- a. Using the same equipment setup as shown in Fig. 6-27, set the sine-wave generator for an output frequency of 60 Hz. Adjust the generator output so the horizontal deflection is exactly 10 cm (20 V).
- b. Set the Type 1A7 VOLTS/CM switch to 10 mVOLTS.
- c. Set both AC-GND-DC switches to AC simultaneously.
- d. Check that the vertical deflection of the display does not exceed 1 cm (CMRR = 2,000:1 or higher).
- e. Set the Horizontal Display switch to Normal and decrease the generator signal output. Disconnect the coaxial cable at the generator. Remove the patch cord and connector adapter. Leave the coaxial cable, T connector and dual-input connector attached to the Type 1A7.

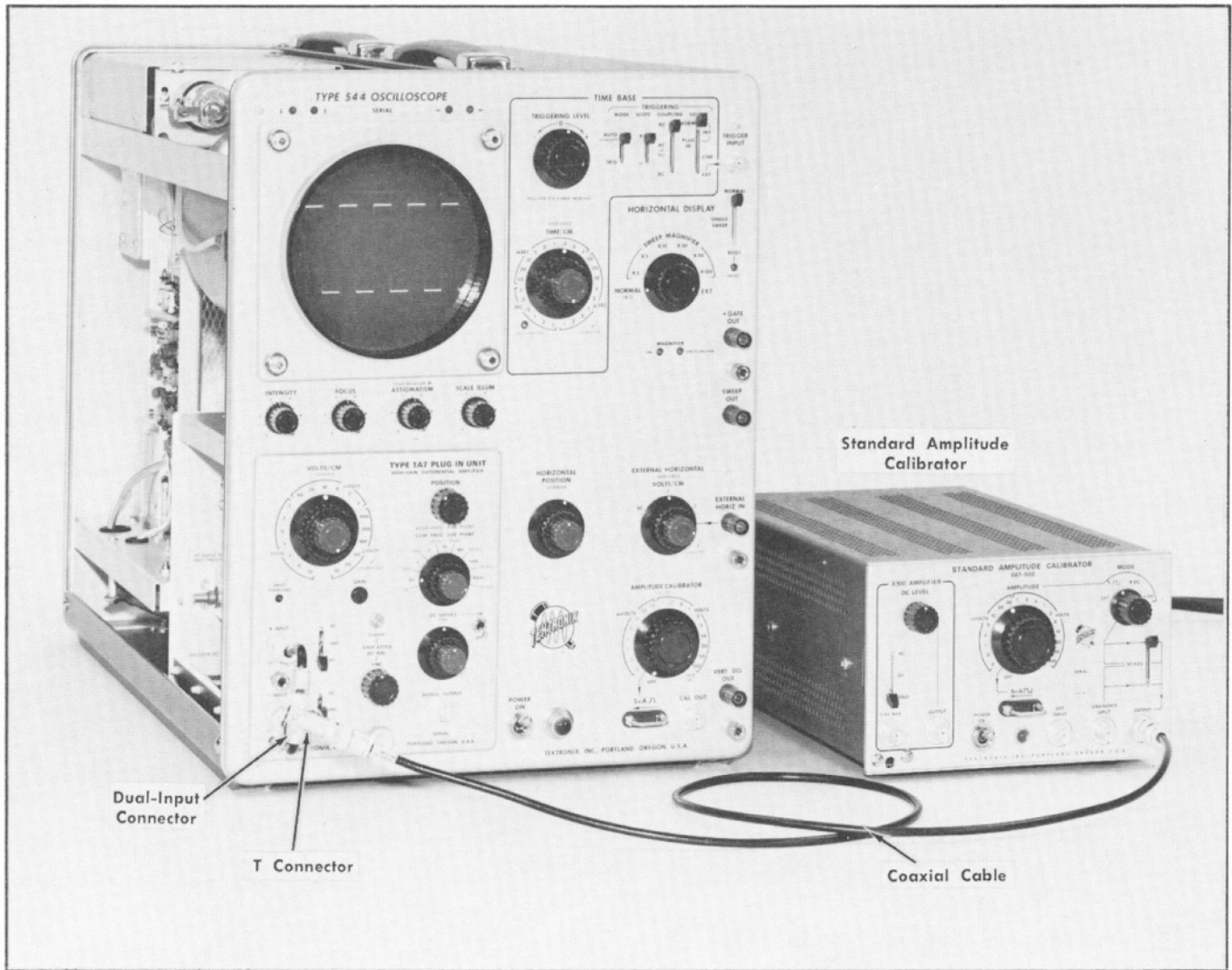

Fig. 6-31. Setup at completion of step 20b.

20. Check Input Attenuator Accuracy

a. Set the Type 1A7 controls as follows:

AC-GND-DC (+INPUT) DC
 AC-GND-DC (—INPUT) GND

At this point in the procedure, the remaining front-panel controls should be at the following positions:

	Type 1A7
VOLTS/CM	10 mVOLTS
VARIABLE	CALIBRATED
POSITION	Midrange

HIGH FREQ 3 dB POINT	500 kHz
LOW FREQ 3 dB POINT	DC
STEP ATTEN DC BAL FINE	Adjusted for proper dc balance (see step 3 NOTE)
DC OFFSET ON-OFF	OFF

	Oscilloscope
Time/cm	.5 mSec
Variable (Time/Cm)	Calibrated
Triggering	+Int, AC, Auto

TABLE 6-2

VOLTS/CM Switch Position	Calibrator Output (Peak to Peak)	Vertical Deflection ⁶ (Accuracy: $\pm 2\%$)
10 mVOLTS	50 mVolts	5 cm (adjusted in step 4)
20 mVOLTS	.1 Volt	5 cm, ± 1 mm
50 mVOLTS	.2 Volt	4 cm, ± 0.8 mm
.1 VOLTS	.5 Volt	5 cm, ± 1 mm
.2 VOLTS	1 Volt	5 cm, ± 1 mm
.5 VOLTS	2 Volts	4 cm, ± 0.8 mm
1 VOLTS	5 Volts	5 cm, ± 1 mm
2 VOLTS	10 Volts	5 cm, ± 1 mm
5 VOLTS	20 Volts	4 cm, ± 0.8 mm
10 VOLTS	50 Volts	5 cm, ± 1 mm

b. Apply a 50-mV peak-to-peak square-wave signal from the standard amplitude calibrator to the coaxial cable. (The signal should now be applied through the coaxial cable, T connector and dual-input connector to the Type 1A7.) Fig. 6-31 shows the setup.

c. Use Table 6-2 as a guide to check the input attenuators. Deflection accuracy should be within $\pm 2\%$ for VOLTS/CM switch positions from 20 mVOLTS to 10 VOLTS.

d. Disconnect the standard amplitude calibrator signal from the T connector.

⁶If there is a spike or fast rolloff on the leading corner of the square wave when checking from 20 mV/cm to 10 V/cm, ignore these as they will be adjusted out in step 22.

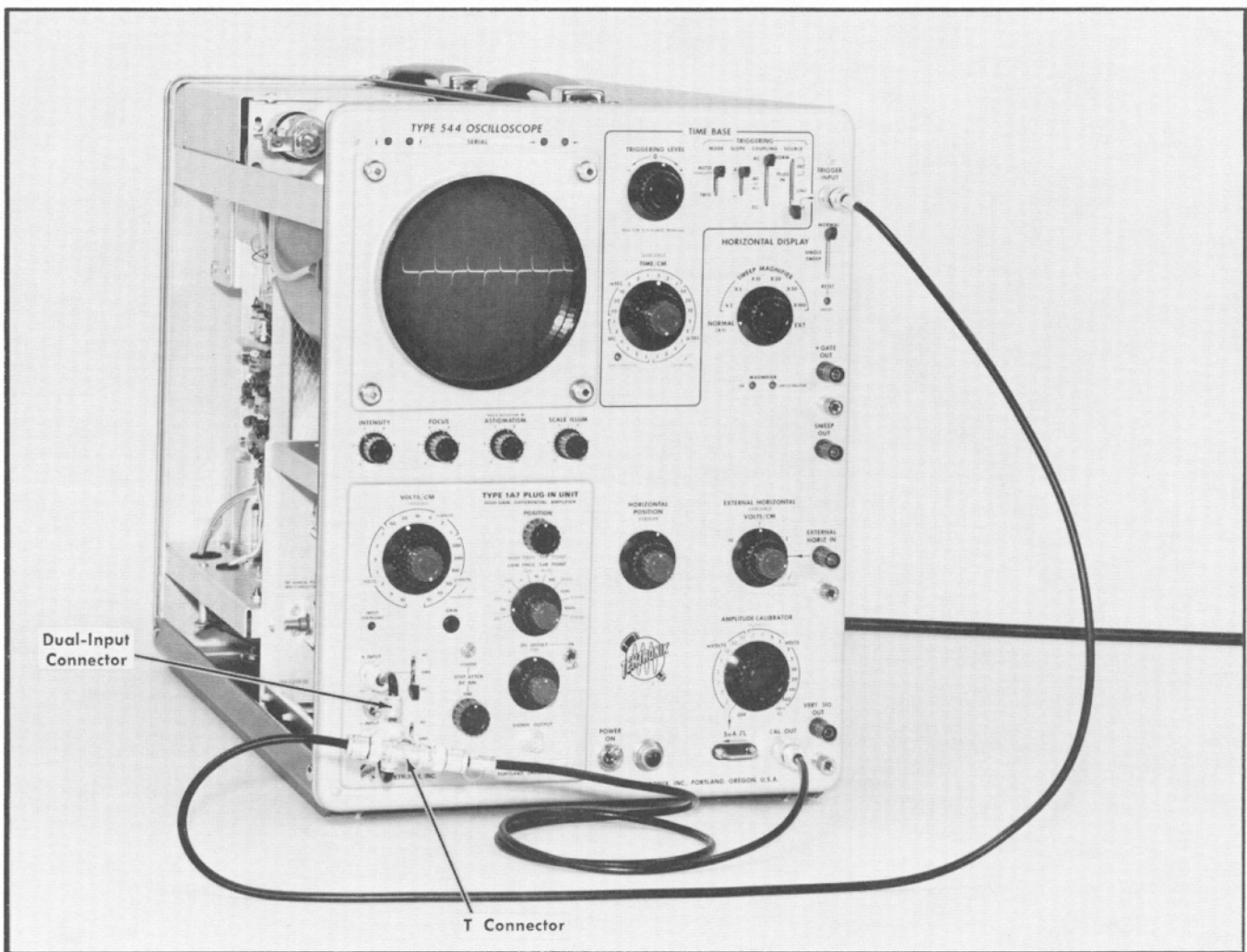

Fig. 6-32. Setup at completion of step 21d.

21. Adjust Attenuator Differential Balance

- a. Set the Type 1A7 controls as follows:

AC-GND-DC (—INPUT)	DC
VOLTS/CM	50 mVOLTS
- b. Set the oscilloscope Triggering Source switch to Ext.
- c. Apply a 50-V peak-to-peak signal from the oscilloscope calibrator through a coaxial cable to the T connector. (The T connector and a dual-input connector are attached to the Type 1A7.)
- d. Connect a coaxial cable from the T connector to the oscilloscope Trigger Input connector. Fig. 6-32 shows the setup.
- e. Check and adjust for optimum differential balance according to the information given in Table 6-3. Ignore the spikes on the waveform. The trailing portion of the cycles must match each other. Fig. 6-33 shows a typical display obtained when R205E is adjusted properly. The displays for the other positions of the VOLTS/CM switch will appear similar. See Fig. 6-34 to locate the adjustments.

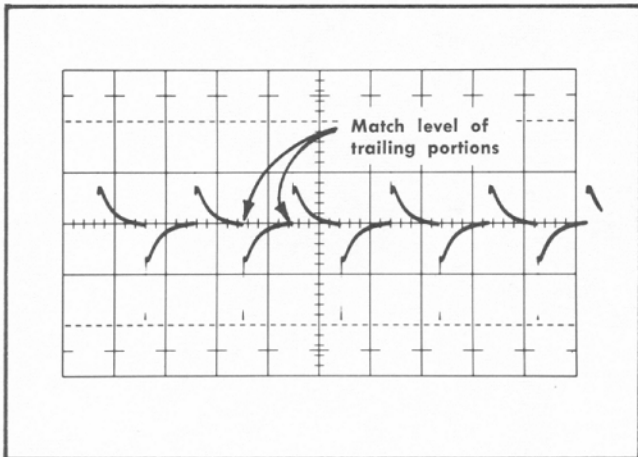

Fig. 6-33. Typical 1-kHz null display obtained when R205E is adjusted properly.

TABLE 6-3

VOLTS/CM Switch Position	Calibrator Output (Peak To Peak)	Check and Adjust for Null	Input Attenuator
50 mVOLTS	50 Volts	Adjust R205E	×10
20 mVOLTS	50 Volts	Check	
.1 VOLTS	50 Volts	Check	
.5 VOLTS	100 Volts	Adjust R206E	×100
.2 VOLTS	100 Volts	Check	
1 VOLTS	100 Volts	Check	
5 VOLTS	100 Volts	Adjust R207E	×1000
2 VOLTS	100 Volts	Check	
10 VOLTS	100 Volts	Check	

- f. Set the calibrator for 0.2-V peak-to-peak output.
- g. Set the oscilloscope Triggering Source switch to Normal (Int).

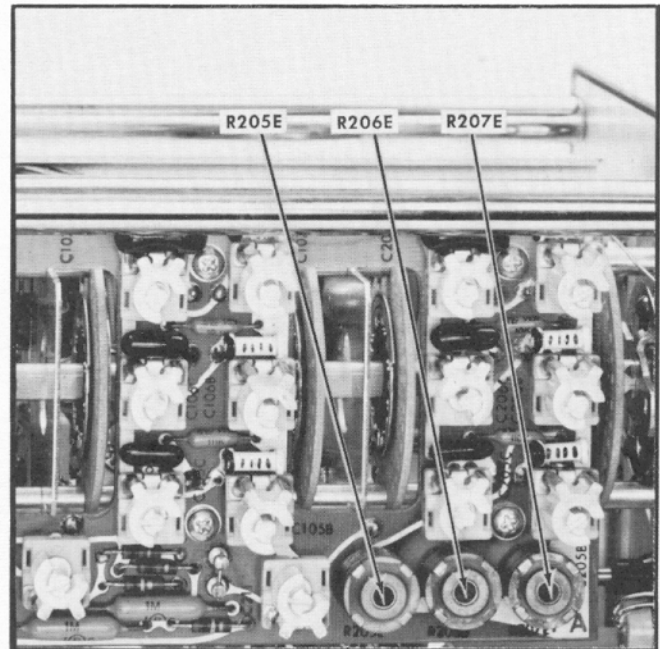

Fig. 6-34. Location of step 21 adjustments

- h. Remove the T connector, dual-input connector and the coaxial cable going to the oscilloscope Trigger Input connector.

22. Adjust +Input Attenuator Compensation

- a. Apply the 0.2-V peak-to-peak signal from the oscilloscope calibrator through a coaxial cable to the +INPUT connector. (The cable connections are the same as that shown in Fig. 6-16.)

- b. Set the Type 1A7 controls as follows:

VOLTS/CM	50 mVOLTS
AC-GND-DC (—INPUT)	GND

At this point in the procedure, the remaining controls should be at the following positions:

Type 1A7

VARIABLE POSITION	CALIBRATED Midrange
HIGH FREQ 3 dB POINT	500 kHz
LOW FREQ 3 dB POINT	DC
AC-GND-DC (+INPUT)	DC
STEP ATTEN DC BAL FINE	Adjusted for proper dc balance (see step 3 NOTE)
DC OFFSET ON-OFF	OFF

Oscilloscope

Time/Cm	.5 mSec
Variable (Time/Cm)	Calibrated
Triggering	+Int, AC, Auto

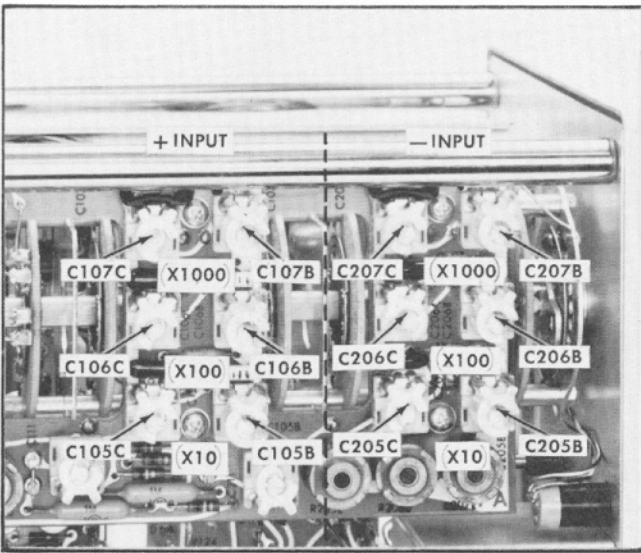

Fig. 6-35. Location of adjustments for steps 22 through 24.

c. Check and adjust the +Input attenuator compensation for best square-wave response according to the sequence given in Table 6-4.

If adjustment is necessary when going through the first half of the table, adjust for optimum top front corner on the second cycle; for the second half of the table adjust for a flat top (similar to Fig. 6-20a). Fig. 6-35 shows the location of all adjustments.

For the check steps in the table, observe the square-wave display. If distortion (rolloff, overshoot or level) is greater than 1% (0.5 mm), it will be necessary to slightly detune the preceding adjustments for that attenuator. The objective is to bring all three VOLTS/CM switch positions to an accuracy of 1%. For example, C105C and C105B are the adjustments for the $\times 10$ +Input attenuator which involves the 20 mVOLTS, 50 mVOLTS and .1 VOLTS positions of the VOLTS/CM switch.

c. Interaction: If this step is performed out of sequence, steps 23 and 24 must be performed.

23. Adjust —Input Attenuator Series Compensation to Match +Input

- a. Remove the standardizer.
- b. Set the oscilloscope Triggering Source switch to Ext.

TABLE 6-4

Calibrator Output (Peak to Peak)	VOLTS/CM Switch Position	Adjust For Optimum		+ Input Attenuator
		Upper Front Corner	Flat Top	
.2 Volt	50 mVOLTS	C105C		$\times 10$
.1 Volt	20 mVOLTS	Check		
.5 Volt	.1 VOLTS	Check		
2 Volts	.5 VOLTS	C106C		$\times 100$
1 Volt	.2 VOLTS	Check		
5 Volts	1 VOLTS	Check		
20 Volts	5 VOLTS	C107C		$\times 1000$
10 Volts	2 VOLTS	Check		
50 Volts	10 VOLTS	Check		
50 Volts [†]	5 VOLTS		C107B	$\times 1000$
20 Volts	2 VOLTS		Check	
100 Volts	10 VOLTS		Check	
5 Volts	.5 VOLTS		C106B	$\times 100$
.2 Volts	.2 VOLTS		Check	
10 Volts	1 VOLTS		Check	
.5 Volt	50 mVOLTS		C105B	$\times 10$
.2 Volt	20 mVOLTS		Check	
1 Volt	.1 VOLTS		Check	

[†]Insert the 47-pF input RC standardizer between the +INPUT connector and the coaxial cable to finish this half of the table. (Fig. 6-19 shows how the standardizer is connected.)

c. Connect the calibrator signal through a coaxial cable, T connector and a dual-input connector to the Type 1A7 +INPUT and -INPUT connectors.

d. Connect a coaxial cable from the T connector to the oscilloscope Trigger Input connector. (The connections are the same as those shown in Fig. 6-32.)

e. Set the Type 1A7 controls as follows:

VOLTS/CM 50 mVOLTS
AC-GND-DC (-INPUT) DC

f. Set the oscilloscope calibrator switch to 50 Volts.

g. Check and adjust the -Input attenuator series compensation for best common-mode signal rejection according to the sequence given in Table 6-5.

If adjustment is necessary, adjust for minimum spike amplitude on the display (similar to Fig. 6-36a). Refer to Fig. 6-35 for the adjustment location.

For the check steps in the table, observe the display to check whether any detuning is necessary. The objective here is to minimize the spike amplitude in all three VOLTS/CM positions for each attenuator as listed. Consider that it is normal for the waveform amplitudes to differ as each VOLTS/CM switch position is checked when the same signal amplitude is applied.

TABLE 6-5

Calibrator Output (Peak To Peak)	VOLTS/CM Switch Position	Adjust for Minimum Spike Amplitude	-Input Attenuator
50 Volts	50 mVOLTS	C205C ^a	×10
	20 mVOLTS	Check	
	.1 VOLTS	Check	
100 Volts	.5 VOLTS	C206C ^b	×100
	.2 VOLTS	Check	
	1 VOLTS	Check	
	5 VOLTS	C207C	
	2 VOLTS	Check	
	10 VOLTS	Check	×1000

^aTypical display is shown in Fig. 6-36a.

^bTypical display is shown in Fig. 6-36b.

24. Adjust -Input Attenuator Shunt Compensation

a. Set the oscilloscope calibrator switch to .5 Volt and the Triggering Source switch to Normal (Int).

b. Remove the dual-input connector, T connector and the coaxial cable going to the oscilloscope Trigger Input connector.

c. Apply the calibrator signal through a coaxial cable and a 47-pF input RC standardizer to the Type 1A7 -INPUT connector. (The connections are the same as shown in Fig. 6-19 except the -INPUT connector is used for this step.)

d. Set the Type 1A7 controls as follows:

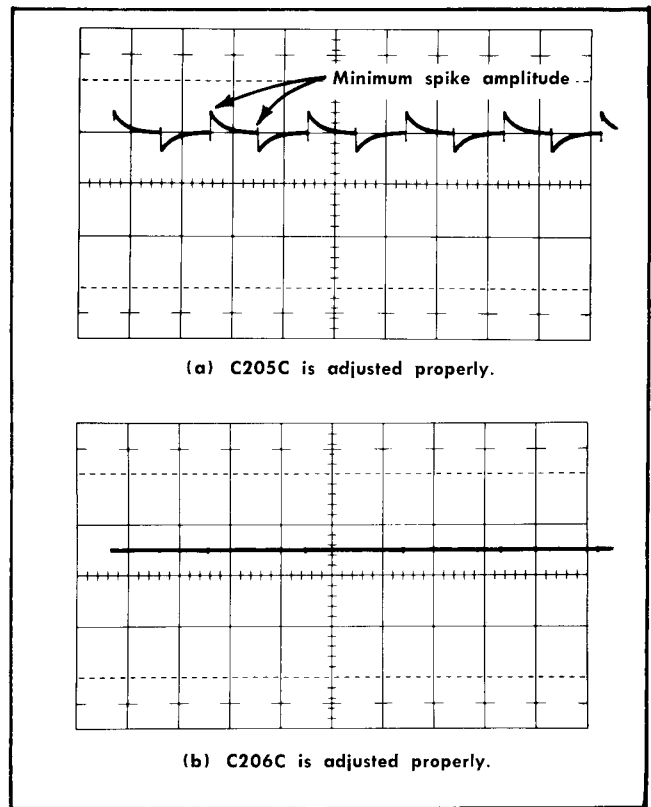

Fig. 6-36. Typical common-mode difference displays obtained when performing step 23.

VOLTS/CM 50 mVOLTS
AC-GND-DC (+INPUT) GND

e. Check and adjust the -INPUT attenuator shunt compensation for best square-wave response according to the sequence given in Table 6-6.

If adjustment is necessary, adjust for best flat bottom on the display (similar to Fig. 6-20a except bottom of waveform is the point of interest).

For the check steps in the table, observe the display to determine if slight detuning is necessary to bring all three VOLTS/CM positions to an accuracy of 1% (0.5 mm) or less for each attenuator as listed.

TABLE 6-6

Calibrator Output (Peak To Peak)	VOLTS/CM Switch Position	Adjust for Optimum Flat Bottom	-Input Attenuator
.5 Volt	50 mVOLTS	C205B	×10
.2 Volt	20 mVOLTS	Check	
1 Volt	.1 mVOLTS	Check	
5 Volts	.5 VOLTS	C206B	×100
2 Volts	.2 VOLTS	Check	
10 Volts	1 VOLTS	Check	
50 Volts	5 VOLTS	C207B	×1000
20 Volts	2 VOLTS	Check	
100 Volts	10 VOLTS	Check	

f. Turn off the oscilloscope calibrator. Disconnect the coaxial cable and standardizer.

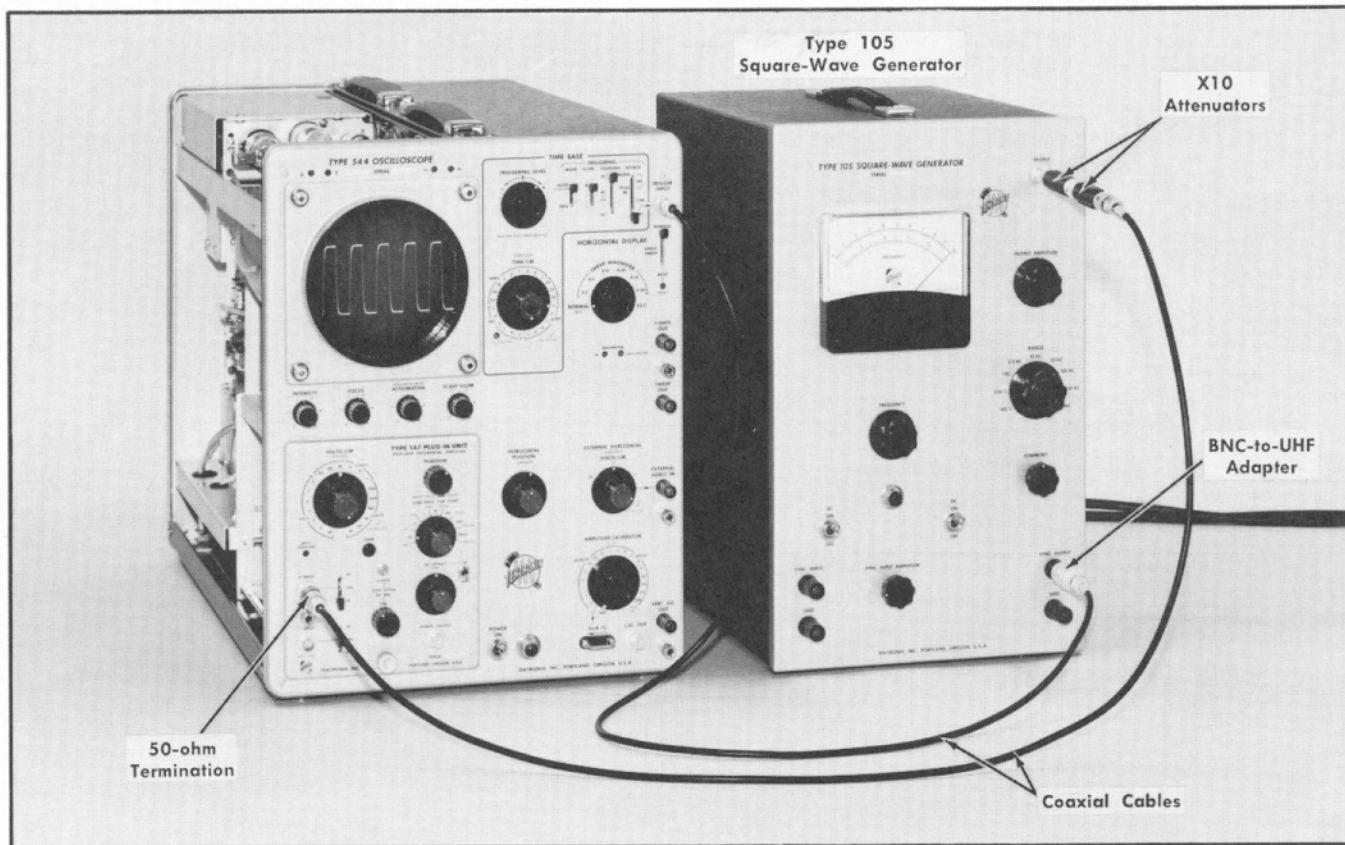

Fig. 6-37. Setup at completion of step 25d.

25. Check Risetime

a. Set the Type 1A7 controls as follows:

VOLTS/CM	10 mVOLTS
AC-GND-DC (+INPUT)	DC
AC-GND-DC (-INPUT)	GND

b. Set the oscilloscope Time/Cm switch to 5 μ Sec and the Triggering Source switch to Ext.

At this point in the procedure, the remaining controls should be at the following positions:

Type 1A7

VARIABLE POSITION	CALIBRATED Midrange
HIGH FREQ 3 dB POINT	500 kHz
LOW FREQ 3 dB POINT	DC
STEP ATTEN DC BAL FINE	Adjusted for proper dc balance (see step 3 NOTE)
DC OFFSET ON-OFF	OFF

Oscilloscope

Variable (Time/Cm)	Calibrated
Triggering	AC, Auto, +

c. Apply a 100-kHz signal from the Type 105 through two 10 \times attenuators, a coaxial cable and a 50-ohm termination (in that order) to the Type 1A7 +INPUT connector.

d. Connect a coaxial cable from the oscilloscope External Trigger Input connector through a BNC-to-UHF connector adapter to the Type 105 Sync Output connector. Fig. 6-37 shows the setup.

e. Adjust the Type 105 Output Amplitude control so the display is 5 cm in amplitude (see Fig. 6-38a).

f. Set the oscilloscope Time/Cm switch to .5 μ Sec. Adjust the triggering controls so the display is stable and the rising portion of the waveform is clearly displayed (see Fig. 6-38b).

g. Check the risetime of the waveform as shown in Fig. 6-38b. Risetime should be between 0.584 μ s and 0.875 μ s, as measured between the 10% and 90% amplitude levels on the rising portion of the waveform. This is equivalent to a bandwidth of 500 kHz, $\pm 20\%$, based on this formula:

$$\text{Equivalent Frequency Response (at upper end 3 dB down point)} = \frac{0.35}{\text{System Risetime}}$$

h. Turn off the Type 105 and disconnect the interconnecting cable and devices.

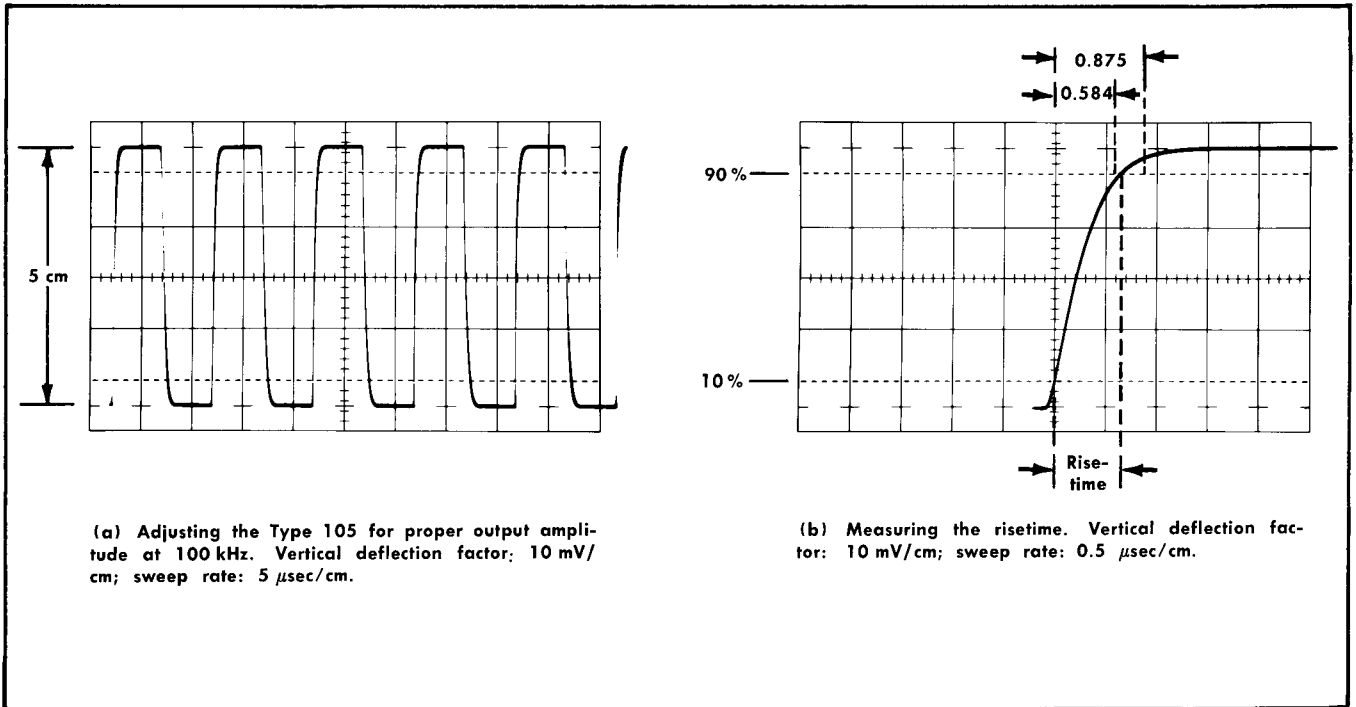

Fig. 6-38. Typical displays obtained when performing step 25.

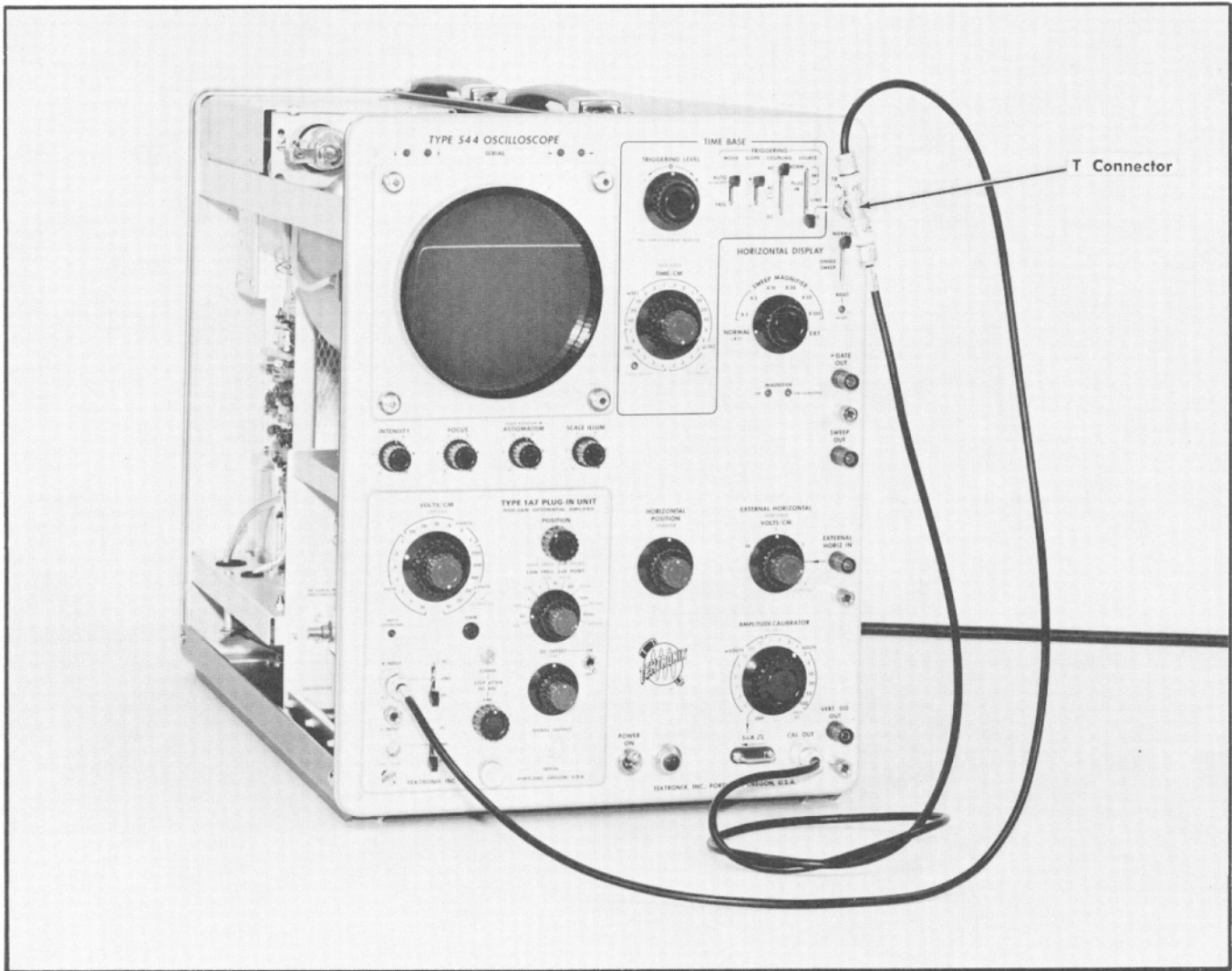

Fig. 6-39. Setup at completion of step 26d.

26. Check HIGH FREQ 3 dB POINT switch

- a. Set the VOLTS/CM switch to .2 VOLTS.
- b. Set the oscilloscope controls as follows:

Time/Cm 2 μ Sec
 Amplitude Calibrator 1 Volt

Up to this point in the procedure, the remaining controls should be at the following positions:

Type 1A7

VARIABLE	CALIBRATED
POSITION	Near midrange
HIGH FREQ 3 dB POINT	500 kHz
LOW FREQ 3 dB POINT	DC
AC-GND-DC (+INPUT)	DC
AC-GND-DC (-INPUT)	GND

STEP ATTEN DC BAL FINE	Adjusted for proper dc balance (see step 3 NOTE)
------------------------	--

DC OFFSET ON-OFF	OFF
------------------	-----

Oscilloscope

Variable (Time/Cm)	Calibrated
Triggering	+Ext, AC, Auto

c. Connect a T connector to the oscilloscope External Trigger Input connector.

d. Connect one coaxial cable from the T connector to the oscilloscope Cal Out connector. Connect a second coaxial cable from the T connector to the Type 1A7 +INPUT connector. Fig. 6-39 shows the setup.

e. Check the display. It should appear similar to the waveform labeled 500 kHz shown in Fig. 6-40a.

NOTE

If automatic triggering on your oscilloscope does not provide a full view of the rising portion of the waveform, use a triggering mode that will provide a suitable display.

f. Check all the other positions of the HIGH FREQ 3 dB POINT switch. Fig. 6-40a and b can be used as a guide for typical displays that should be obtained. Be sure to set the oscilloscope Time/Cm switch to .1 mSec to obtain the displays shown in Fig. 6-40b.

27. Check LOW FREQ 3 dB POINT switch

a. Set the Type 1A7 controls as follows:

VOLTS/CM .5 VOLTS

HIGH FREQ 3 dB POINT 500 kHz

b. Set the oscilloscope Time/Cm switch to .5 mSec.

c. Using the Type 1A7 POSITION control, position the display near the top of the graticule as shown in Fig. 6-41a. Check all the remaining positions of the LOW FREQ 3 dB POINT switch using Fig. 6-41b through d as a guide.

d. Disconnect the calibrator signal, interconnecting cables and T connector.

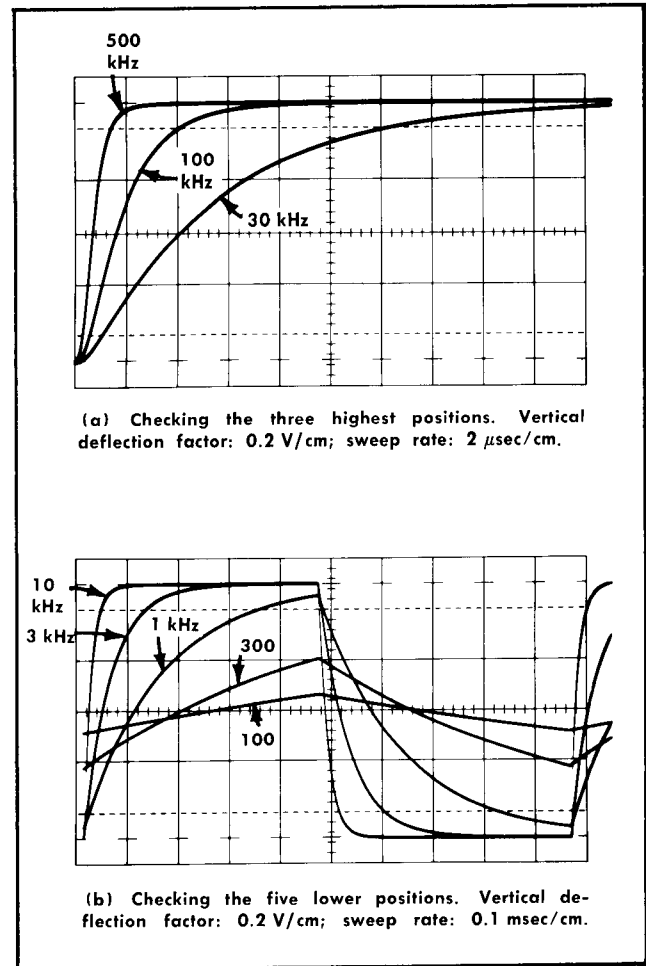
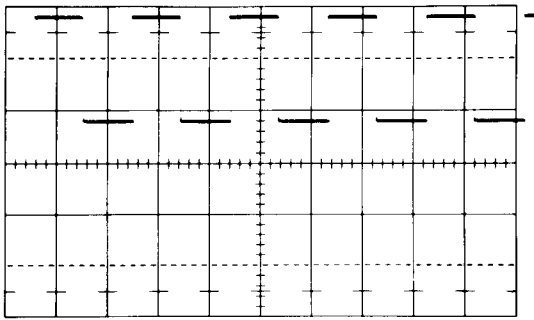
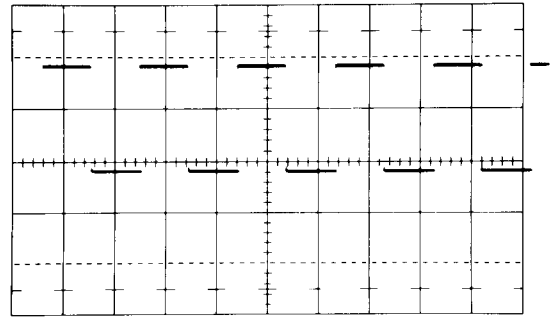

Fig. 6-40. Multiple exposure photographs showing effect of HIGH FREQ 3 dB POINT switch on a 1-kHz calibrator signal. LOW FREQ 3 dB POINT switch is set to DC.



(a) Positioning the display near the top of the graticule. Waveform obtained when LOW FREQ 3 dB POINT switch is set to DC. Vertical deflection factor: 0.5 V/cm; sweep rate: 0.5 msec/cm.



(b) LOW FREQ 3 dB POINT switch set to .1 display shifted downward to an average level. Then switch is set to 1. No change in waveshape.

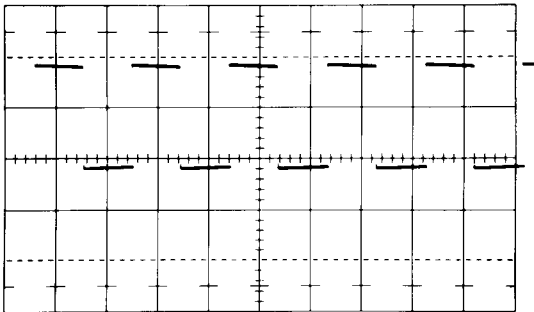

(c) LOW FREQ 3 dB POINT switch is set to 10. Square waves show slight tilt.

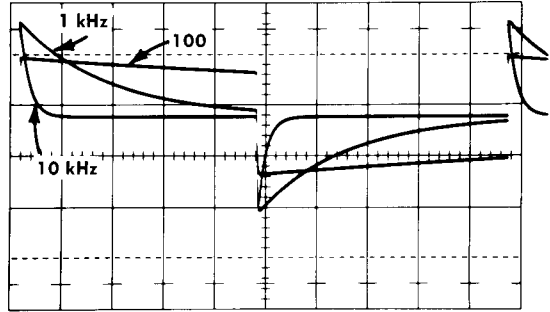

(d) Multiple exposure showing effect obtained when checking the three highest positions. Vertical deflection factor: 0.5 V/cm; sweep rate: 0.1 msec/cm.

Fig. 6-41. Checking all positions of the LOW FREQ 3 dB POINT switch. HIGH FREQ 3 dB POINT switch is set to 500 kHz.

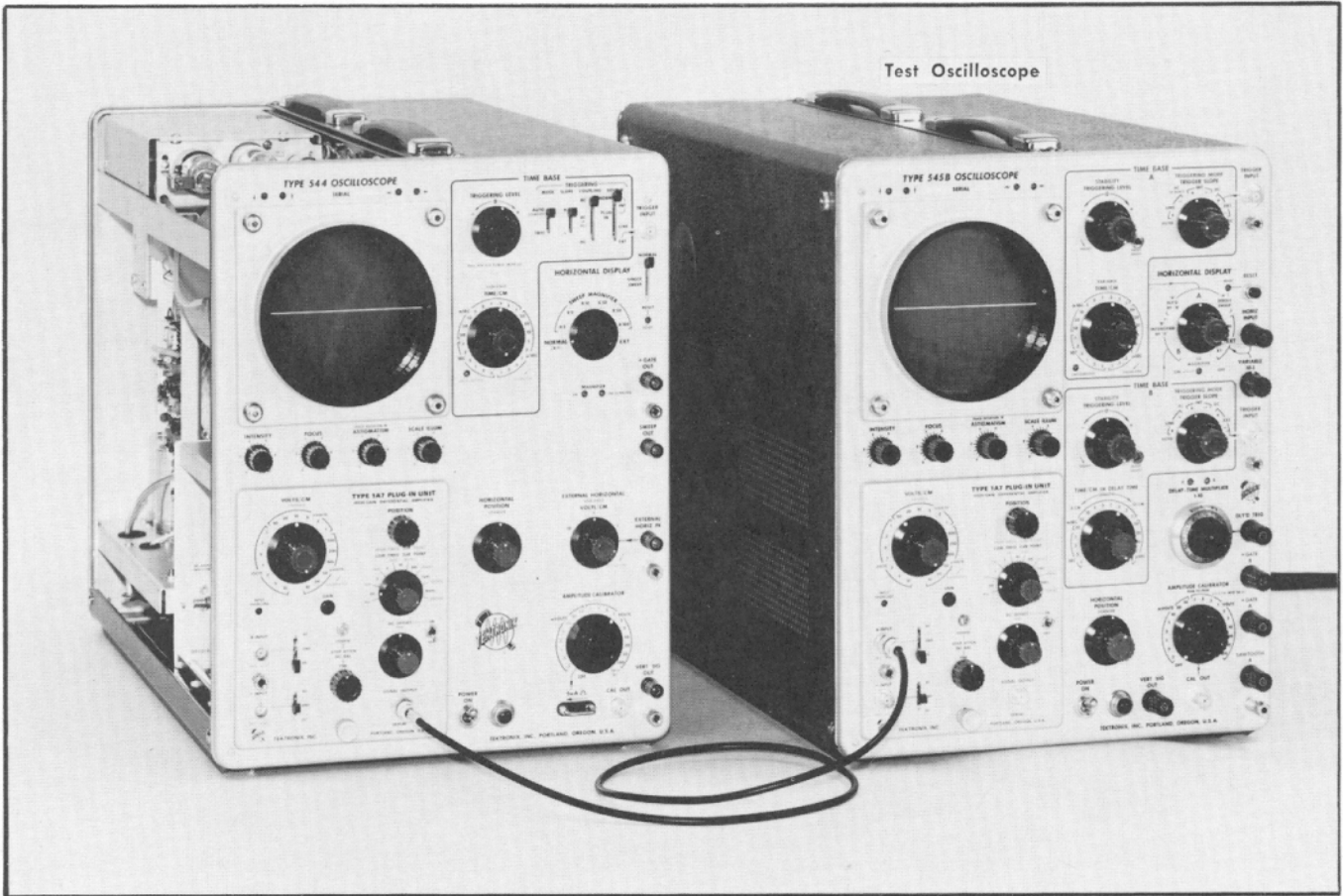

Fig. 6-42. Setup at completion of step 28e.

28. Adjust SIGNAL OUTPUT DC LEVEL (R490) ①

a. Set the Type 1A7 controls as follows:

VOLTS/CM 10 mVOLTS
 LOW FREQ 3 dB POINT DC

b. Set the oscilloscope Triggering Source switch to Normal (Int) and the Time/Cm switch to .5mSec.

Up to this point in the procedure, the remaining controls should be at the following positions:

Type 1A7

VARIABLE POSITION	CALIBRATED
HIGH FREQ 3 dB POINT	Near midrange
AC-GND-DC (+INPUT)	500 kHz
AC-GND-DC (-INPUT)	DC
STEP ATTEN DC BAL FINE	GND
	Adjusted for proper dc balance (see step 3 NOTE)
DC OFFSET ON-OFF	OFF

Oscilloscope

Variable Triggering	Calibrated AC, Auto, +
---------------------	------------------------

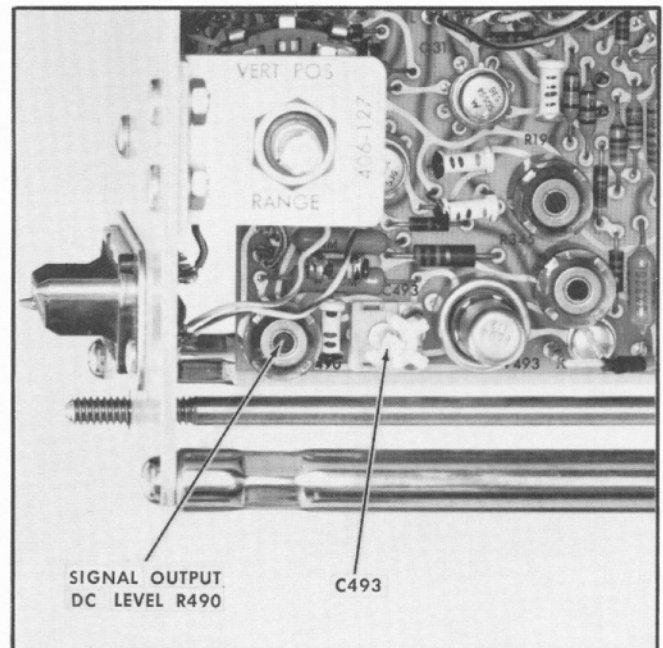

Fig. 6-43. Location of adjustments for steps 28 and 30.

Calibration—Type 1A7

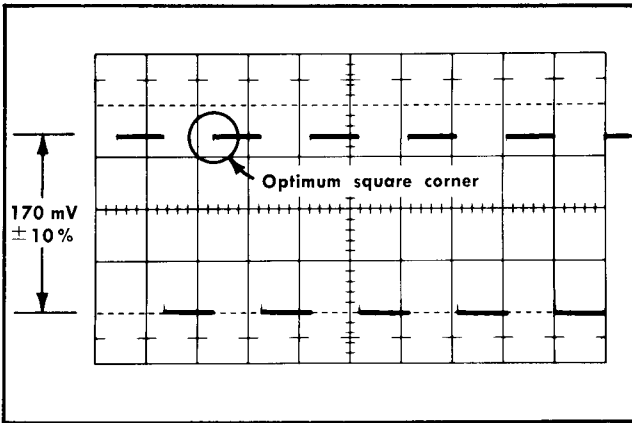

Fig. 6-44. Typical display obtained on the test oscilloscope when checking the SIGNAL OUTPUT gain and adjustment of C493.

c. Set the test oscilloscope for dc-input coupling, a vertical deflection factor of 50 mV/cm and free run the sweep at .5 msec/cm.

d. Position the traces on both oscilloscopes so they coincide with graticule center.

e. Connect a coaxial cable between the Type 1A7 SIGNAL OUTPUT connector and the test oscilloscope vertical input connector. Fig. 6-42 shows the setup.

f. Check that the trace on the test oscilloscope is centered. If it is not, adjust the SIGNAL OUTPUT DC LEVEL control (R490; see Fig. 6-43) to return the trace to graticule center (zero volts indication on the test oscilloscope).

29. Check SIGNAL OUTPUT Gain

a. Using the same setup as shown in Fig. 6-42, apply a 50-mV peak-to-peak signal from the oscilloscope calibrator through another coaxial cable to the +INPUT connector.

b. Check the test oscilloscope display for an amplitude of 170 mV peak to peak within a tolerance of $\pm 10\%$, 3.4 cm ± 3.4 mm (see Fig. 6-44).

30. Adjust C493—SIGNAL OUTPUT Divider Compensation

a. Check the upper front corner on the test oscilloscope display. The waveform should appear similar to the one shown in Fig. 6-44. If the top of the waveform is not flat, adjust C493 (see Fig. 6-43) for optimum square waveshape.

b. Disconnect the coaxial cables and turn off the test oscilloscope.

31. Check Noise

a. Set the Type 1A7 controls as follows:

VOLTS/CM	10 μ VOLTS
AC-GND-DC.(+INPUT)	GND

At this point in the procedure, the remaining controls should be at the following position:

Type 1A7

VARIABLE	CALIBRATED
POSITION	Midrange
HIGH FREQ 3 dB POINT	500 kHz
LOW FREQ 3 dB POINT	DC
AC-GND-DC (-INPUT)	GND
STEP ATTEN DC BAL FINE	Adjusted for proper dc balance (see step 3 NOTE)
DC OFFSET ON-OFF	OFF

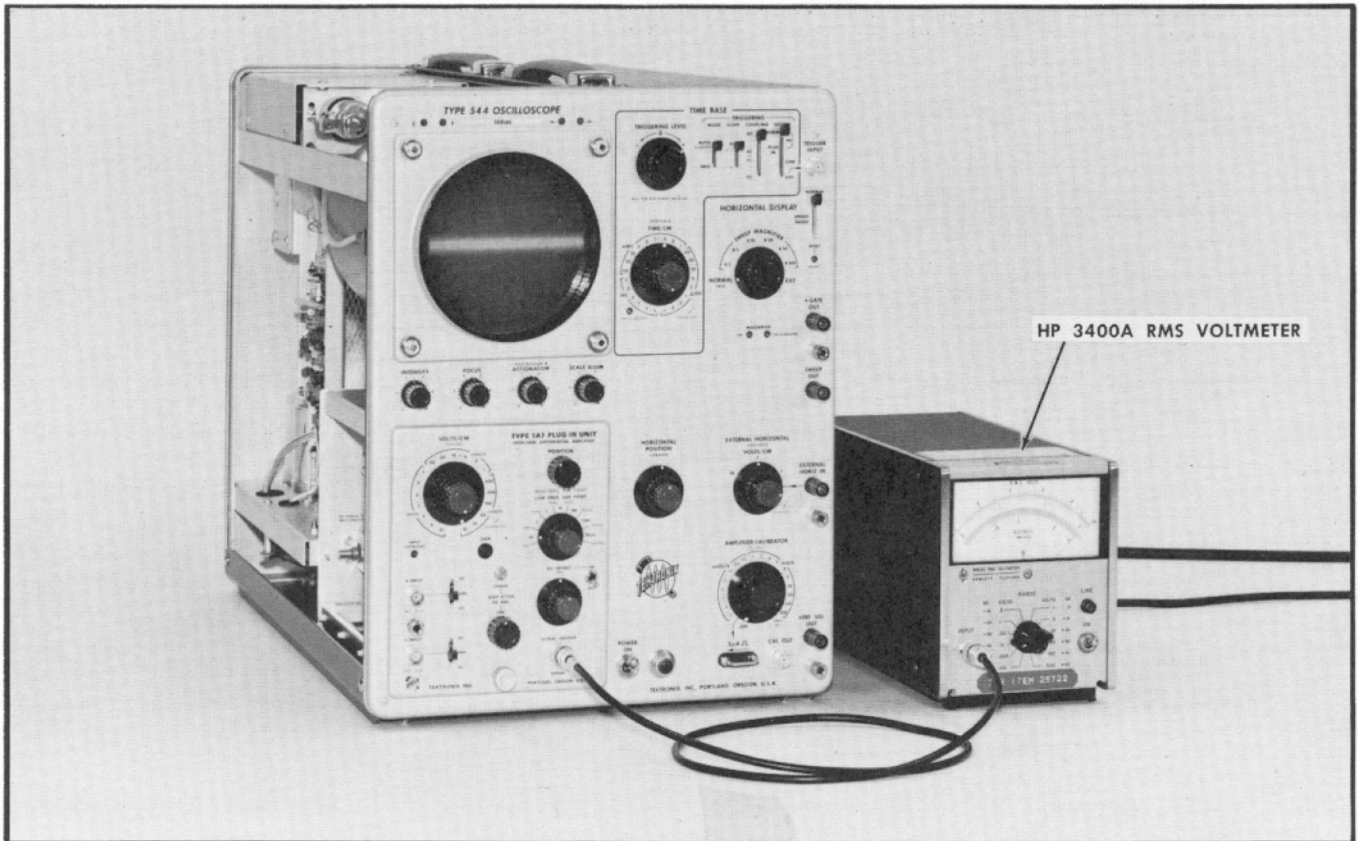

Fig. 6-45. Setup at completion of step 31b.

Oscilloscope

Time/Cm	.5 mSec
Variable (Time/Cm)	Calibrated
Triggering	+Int, AC, Auto

b. Connect an rms voltmeter between the SIGNAL OUTPUT connector and ground. Fig. 6-45 shows the setup. The voltmeter reading should be 10.2 mV or less. (If an average reading rms calibrated voltmeter is used, a correction factor of 1.13 must be applied to the noise measurement. To obtain the true rms value, multiply the reading by 1.13. Thus, the average reading rms calibrated voltmeter should read 9 mV or less.)

NOTE

As an alternative method, if neither voltmeter is available, check noise amplitude by observing the display. 90% of the peaks should fall within 20 μ V (2 cm) peak-to-peak amplitude or less (see Fig. 6-46).

This completes the calibration of the Type 1A7. Disconnect the voltmeter, if used. Replace the left side panel on the oscilloscope. If the unit has been completely calibrated

to the tolerances given in the procedure, it will perform to the limits given in the Characteristics section of this Instruction Manual.

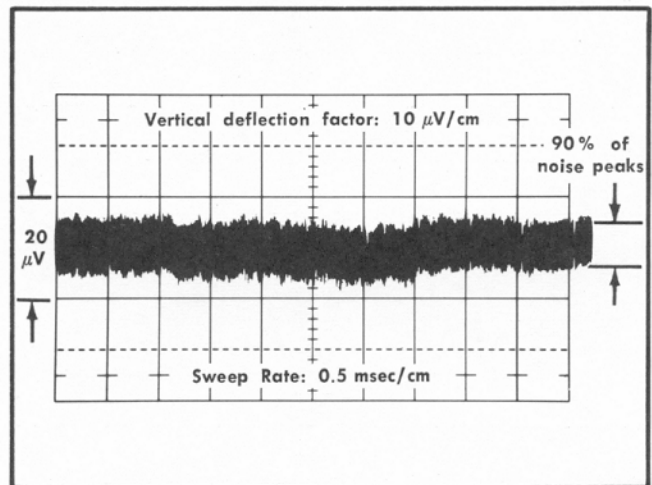

Fig. 6-46. Typical single-shot display obtained when checking noise amplitude. 90% of the peaks should fall within 20 μ V peak to peak.

ABBREVIATIONS AND SYMBOLS

A or amp	amperes	L	inductance
AC or ac	alternating current	λ	lambda—wavelength
AF	audio frequency	\gg	large compared with
α	alpha—common-base current amplification factor	$<$	less than
AM	amplitude modulation	LF	low frequency
\approx	approximately equal to	lg	length or long
β	beta—common-emitter current amplification factor	LV	low voltage
BHB	binding head brass	M	mega or 10^6
BHS	binding head steel	m	milli or 10^{-3}
BNC	baby series "N" connector	M Ω or meg	megohm
X	by or times	μ	micro or 10^{-6}
C	carbon	mc	megacycle
C	capacitance	met.	metal
cap.	capacitor	MHz	megahertz
cer	ceramic	mm	millimeter
cm	centimeter	ms	millisecond
comp	composition	—	minus
conn	connector	mtg hdw	mounting hardware
\sim	cycle	n	nano or 10^{-9}
c/s or cps	cycles per second	no. or #	number
CRT	cathode-ray tube	ns	nanosecond
csk	countersunk	OD	outside diameter
Δ	increment	OHB	oval head brass
dB	decibel	OHS	oval head steel
dBm	decibel referred to one milliwatt	Ω	omega—ohms
DC or dc	direct current	ω	omega—angular frequency
DE	double end	p	pico or 10^{-12}
$^{\circ}$	degrees	/	per
$^{\circ}$ C	degrees Celsius (degrees centigrade)	%	percent
$^{\circ}$ F	degrees Fahrenheit	PHB	pan head brass
$^{\circ}$ K	degrees Kelvin	ϕ	phi—phase angle
dia	diameter	π	pi—3.1416
\div	divide by	PHS	pan head steel
div	division	+	plus
EHF	extremely high frequency	\pm	plus or minus
elect.	electrolytic	PIV	peak inverse voltage
EMC	electrolytic, metal cased	plstc	plastic
EMI	electromagnetic interference (see RFI)	PMC	paper, metal cased
EMT	electrolytic, metal tubular	poly	polystyrene
ϵ	epsilon—2.71828 or % of error	prec	precision
\geq	equal to or greater than	PT	paper, tubular
\leq	equal to or less than	PTM	paper or plastic, tubular, molded
ext	external	pwr	power
F or f	farad	Q	figure of merit
F & I	focus and intensity	RC	resistance capacitance
FHB	flat head brass	RF	radio frequency
FHS	flat head steel	RFI	radio frequency interference (see EMI)
Fil HB	fillister head brass	RHB	round head brass
Fil HS	fillister head steel	ρ	rho—resistivity
FM	frequency modulation	RHS	round head steel
ft	feet or foot	r/min or rpm	revolutions per minute
G	giga or 10^9	RMS	root mean square
g	acceleration due to gravity	s or sec.	second
Ge	germanium	SE	single end
GHz	gigahertz	Si	silicon
GMV	guaranteed minimum value	SN or S/N	serial number
GR	General Radio	\ll	small compared with
$>$	greater than	T	tera or 10^{12}
H or h	henry	TC	temperature compensated
h	height or high	TD	tunnel diode
hex.	hexagonal	THB	truss head brass
HF	high frequency	Θ	theta—angular phase displacement
HHB	hex head brass	thk	thick
HHS	hex head steel	THS	truss head steel
HSB	hex socket brass	tub.	tubular
HSS	hex socket steel	UHF	ultra high frequency
HV	high voltage	V	volt
Hz	hertz (cycles per second)	VAC	volts, alternating current
ID	inside diameter	var	variable
IF	intermediate frequency	VDC	volts, direct current
in.	inch or inches	VHF	very high frequency
incd	incandescent	VSWR	voltage standing wave ratio
∞	infinity	W	watt
int	internal	w	wide or width
\int	integral	w/	with
k	kilohms or kilo (10^3)	w/o	without
k Ω	kilohm	WW	wire-wound
kc	kilocycle	xmfr	transformer
kHz	kilohertz		



PARTS ORDERING INFORMATION

Replacement parts are available from or through your local Tektronix, Inc. Field Office or representative.

Changes to Tektronix instruments are sometimes made to accommodate improved components as they become available, and to give you the benefit of the latest circuit improvements developed in our engineering department. It is therefore important, when ordering parts, to include the following information in your order: Part number, instrument type or number, serial or model number, and modification number if applicable.

If a part you have ordered has been replaced with a new or improved part, your local Tektronix, Inc. Field Office or representative will contact you concerning any change in part number.

SPECIAL NOTES AND SYMBOLS

- | | |
|---|---|
| ×000 | Part first added at this serial number |
| 00× | Part removed after this serial number |
| *000-0000-00 | Asterisk preceding Tektronix Part Number indicates manufactured by or for Tektronix, Inc., or reworked or checked components. |
| Use 000-0000-00 | Part number indicated is direct replacement. |
|  | Screwdriver adjustment. |
|  | Control, adjustment or connector. |

SECTION 7

ELECTRICAL PARTS LIST

Values are fixed unless marked Variable.

Ckt. No.	Tektronix Part No.	Description			S/N Range
Bulb					
B309	150-0035-00	Neon, A1D			
Capacitors					
Tolerance $\pm 20\%$ unless otherwise indicated.					
C101	281-0518-00	47 pF	Cer	500 V	
C102†	*295-0081-00	0.1 μ F	PTM	600 V	10%
C105A	281-0576-00	11 pF	Cer	500 V	5%
C105B	281-0081-00	1.8-13 pF	Air	Var	
C105C	281-0078-00	1.4-7.3 pF	Air	Var	
C105D	283-0601-00	22 pF	Mica	300 V	10%
C106A	281-0576-00	11 pF	Cer	500 V	5%
C106B	281-0081-00	1.8-13 pF	Air	Var	
C106C	281-0078-00	1.4-7.3 pF	Air	Var	
C106D	283-0597-00	470 pF	Mica	300 V	10%
C107A	281-0576-00	11 pF	Cer	500 V	5%
C107B	281-0081-00	1.8-13 pF	Air	Var	
C107C	281-0078-00	1.4-7.3 pF	Air	Var	
C107D	283-0617-00	4700 pF	Mica	300 V	10%
C111	281-0081-00	1.8-13 pF	Air	Var	
C121	281-0064-00	0.2-1.6 pF	Tub.	Var	
C143	281-0117-00	1.7-11 pF	Air	Var	
C144	281-0116-00	1.6-9.1 pF	Air	Var	
C155	283-0059-00	1 μ F	Cer	25 V	+80% —20%
C185	283-0065-00	0.001 μ F	Cer	100 V	5%
C190	290-0290-00	10 μ F	EMT	25 V	
C201	281-0518-00	47 pF	Cer	500 V	
C202†	*295-0081-00	0.1 μ F	PTM	600 V	10%
C205A	281-0576-00	11 pF	Cer	500 V	5%
C205B	281-0081-00	1.8-13 pF	Air	Var	
C205C	281-0078-00	1.4-7.3 pF	Air	Var	
C205D	283-0601-00	22 pF	Mica	300 V	10%
C206A	281-0576-00	11 pF	Cer	500 V	5%
C206B	281-0081-00	1.8-13 pF	Air	Var	
C206C	281-0078-00	1.4-7.3 pF	Air	Var	
C206D	283-0597-00	470 pF	Mica	300 V	10%
C207A	281-0576-00	11 pF	Cer	500 V	5%
C207B	281-0081-00	1.8-13 pF	Air	Var	
C207C	281-0078-00	1.4-7.3 pF	Air	Var	
C207D	283-0617-00	4700 pF	Mica	300 V	10%

† C102 and C202 matched within $\pm 1\%$ of each other, furnished as a unit.

Electrical Parts List—Type 1A7

Capacitors (Cont'd)

Ckt. No.	Tektronix Part No.		Description			S/N Range
C211	281-0081-00	1.8-13 pF	Air	Var		
C221	281-0064-00	0.2-1.6 pF	Tub.	Var		
C226	285-0598-00	0.01 μ F	PTM		100 V	5%
C227	285-0626-00	0.0015 μ F	PTM		100 V	10%
C246	283-0002-00	0.01 μ F	Cer		150 V	
C309	281-0543-00	270 pF	Cer		500 V	10%
C311	281-0529-00	1.5 pF	Cer		500 V	± 0.25 pF
C327	281-0540-00	51 pF	Cer			5%
C330A	290-0292-00	1000 μ F	EMT		25 V	
C330B	290-0291-00	100 μ F	EMT		25 V	
C330C	290-0290-00	10 μ F	EMT		25 V	
C330D	290-0289-00	1 μ F	EMT		25 V	
C330E	285-0703-00	0.1 μ F	PTM		100 V	5%
C330F	285-0598-00	0.01 μ F	PTM		100 V	5%
C335A	283-0620-00	470 pF	Mica			1%
C335B	281-0638-00	240 pF	Cer		500 V	5%
C335C	281-0637-00	91 pF	Cer		500 V	5%
C335D	281-0622-00	47 pF	Cer		500 V	1%
C351	281-0627-00	1 pF	Cer		600 V	
C370A	285-0703-00	0.1 μ F	PTM		100 V	5%
C370B	285-0702-00	0.33 μ F	PTM		100 V	5%
C370C	285-0598-00	0.01 μ F	PTM		100 V	5%
C370D	285-0627-00	0.0033 μ F	PTM		100 V	5%
C370E	283-0065-00	0.001 μ F	Cer		100 V	5%
C370F	283-0604-00	304 pF	Mica		300 V	2%
C370G	283-0616-00	75 pF	Mica		500 V	5%
C411	281-0529-00	1.5 pF	Cer		500 V	± 0.25 pF
C451	281-0627-00	1 pF	Cer		600 V	
C492	281-0544-00	5.6 pF	Cer		500 V	10%
C493	281-0081-00	1.8-13 pF	Air	Var		
C501	290-0261-00	6.8 μ F	EMT		35 V	
C504	283-0065-00	0.001 μ F	Cer		100 V	5%
C521	283-0000-00	0.001 μ F	Cer		500 V	
C524	283-0000-00	0.001 μ F	Cer		500 V	
C528	283-0000-00	0.001 μ F	Cer		500 V	

Diodes

D122	*152-0165-00	Silicon	Selected from 1N3579
D222	*152-0165-00	Silicon	Selected from 1N3579
D305	152-0166-00	Zener	1N753A 0.4 W, 6.2 V, 5%
D405	152-0166-00	Zener	1N753A 0.4 W, 6.2 V, 5%
D507	152-0212-00	Zener	1N936 9 V, 5% TC

Connectors

Ckt. No.	Tektronix Part No.	Description	S/N Range
J101	131-0106-00	Chassis mounted, 1 contact female	
J201	131-0106-00	Chassis mounted, 1 contact female	
J495	131-0106-00	Chassis mounted, 1 contact female	

Inductors

L123	*108-0147-00	2.2 μ H
L133	*108-0147-00	2.2 μ H
L223	*108-0147-00	2.2 μ H
L233	*108-0147-00	2.2 μ H

Transistors

Q144†	*153-0536-00	Selected from 2N3440
Q154	151-0150-00	2N3440
Q158	*151-0136-00	Replaceable by 2N3053
Q183	*151-0096-00	Selected from 2N1893
Q184	*151-0133-00	Selected from 2N3251
Q193A,B	*151-0178-00	Dual, replaceable by 2N3808
Q244†	*153-0536-00	Selected from 2N3440
Q254	151-0150-00	2N3440
Q304	*151-0096-00	Selected from 2N1893
Q314A,B	*151-0178-00	Dual, replaceable by 2N3808
Q324††	*153-0535-00	Selected from 2N3251
Q354A,B	*151-0178-00	Dual, replaceable by 2N3808
Q364	*151-0133-00	Selected from 2N3251
Q404	*151-0096-00	Selected from 2N1893
Q424††	*153-0535-00	Selected from 2N3251
Q504A,B	*151-0176-00	Dual, replaceable by 2N3409
Q517	*151-0136-00	Replaceable by 2N3053

Resistors

Resistors are fixed, composition, $\pm 10\%$ unless otherwise indicated.

R101	315-0105-00	1 M Ω	$\frac{1}{4}$ W		5%
R105C	323-0611-01	900 k	$\frac{1}{2}$ W	Prec	$\frac{1}{2}\%$
R105D	321-1389-01	111 k	$\frac{1}{8}$ W	Prec	$\frac{1}{2}\%$
R106C	323-0614-01	990 k	$\frac{1}{2}$ W	Prec	$\frac{1}{2}\%$
R106D	321-1289-01	10.1 k	$\frac{1}{8}$ W	Prec	$\frac{1}{2}\%$
R107C	323-0623-01	999 k	$\frac{1}{2}$ W	Prec	$\frac{1}{2}\%$
R107D	321-0193-01	1 k	$\frac{1}{8}$ W	Prec	$\frac{1}{2}\%$
R112	323-0481-01	1 M Ω	$\frac{1}{2}$ W	Prec	$\frac{1}{2}\%$
R113	315-0101-00	100 Ω	$\frac{1}{4}$ W		5%
R114	315-0104-00	100 k	$\frac{1}{4}$ W		5%

†Q144 and Q244 furnished as a pair (matched pair).

††Q324 and Q424 furnished as a unit (matched pair).

Electrical Parts List—Type 1A7

Resistors (Cont'd)

Ckt. No.	Tektronix Part No.		Description		S/N Range
R115	311-0510-00	10 k		Var	
R116	301-0563-00	56 k	1/2 W		5%
R123	316-0561-00	560 Ω	1/4 W		
R133	316-0561-00	560 Ω	1/4 W		
R144	308-0306-00	3.26 k	3 W		WW 2%
R145	308-0367-00	2.9 k	3 W		WW 1%
R151A	323-0404-00	158 k	1/2 W		Prec 1%
R151B	323-0404-00	158 k	1/2 W		Prec 1%
R151C	323-0404-00	158 k	1/2 W		Prec 1%
R152A	323-0345-00	38.3 k	1/2 W		Prec 1%
R152B	323-0345-00	38.3 k	1/2 W		Prec 1%
R153	308-0172-00	3.5 k	5 W		WW 5%
R154	322-0164-00	499 Ω	1/4 W		Prec 1%
R161	323-0258-00	4.75 k	1/2 W		Prec 1%
R162	323-0222-00	2 k	1/2 W		Prec 1%
R163	323-0227-00	2.26 k	1/2 W		Prec 1%
R164A	323-0349-00	42.2 k	1/2 W		Prec 1%
R164B	323-0349-00	42.2 k	1/2 W		Prec 1%
R165†	311-0569-00	20 k		Var	
R167	315-0333-00	33 k	1/4 W		5%
R168†	311-0569-00	5 k		Var	
R169	315-0271-00	270 Ω	1/4 W		5%
R170	311-0224-00	50 k		Var	
R171	315-0105-00	1 MΩ	1/4 W		5%
R172	315-0473-00	47 k	1/4 W		5%
R173	301-0303-00	30 k	1/2 W		5%
R174	315-0105-00	1 MΩ	1/4 W		5%
R175	311-0552-00	1 MΩ		Var	
R179	*310-0540-00	30 Ω	2 W		Prec 1%
R181	315-0334-00	330 k	1/4 W		5%
R182	315-0133-00	13 k	1/4 W		5%
R183	315-0753-00	75 k	1/4 W		5%
R185	315-0162-00	1.6 k	1/4 W		5%
R187	322-0336-00	30.9 k	1/4 W		Prec 1%
R188	315-0273-00	27 k	1/4 W		5%
R189	322-0347-00	40.2 k	1/4 W		Prec 1%
R190	311-0551-00	500 k		Var	
R193	322-0357-00	51.1 k	1/4 W		Prec 1%
R194	301-0183-00	18 k	1/2 W		5%
R201	315-0105-00	1 MΩ	1/4 W		5%
R205C	323-0611-01	900 k	1/2 W		Prec 1/2%
R205D	321-0389-01	110 k	1/8 W		Prec 1/2%
R205E	311-0496-00	2.5 k		Var	
R206C	323-0614-01	990 k	1/2 W		Prec 1/2%
R206D	321-0289-01	10 k	1/8 W		Prec 1/2%

†R165 and R168 furnished as a unit.

Resistors (Cont'd)

Ckt. No.	Tektronix Part No.		Description			S/N Range
R206E	311-0442-00	250 Ω		Var		
R207C	323-0623-01	999 k	1/2 W		Prec	1/2%
R207D	321-0191-00	953 Ω	1/8 W		Prec	1%
R207E	311-0433-00	100 Ω		Var		
R212	323-0481-01	1 MΩ	1/2 W		Prec	1/2%
R213	315-0101-00	100 Ω	1/4 W			5%
R214	315-0104-00	100 k	1/4 W			5%
R215	311-0510-00	10 k		Var		
R223	316-0561-00	560 Ω	1/4 W			
R226	315-0133-00	13 k	1/4 W			5%
R227	315-0392-00	3.9 k	1/4 W			5%
R233	316-0561-00	560 Ω	1/4 W			
R244	308-0306-00	3.26 k	3 W		WW	2%
R254	322-0164-00	499 Ω	1/4 W		Prec	1%
R271	315-0105-00	1 MΩ	1/4 W			5%
R272	315-0473-00	47 k	1/4 W			5%
R274	315-0105-00	1 MΩ	1/4 W			5%
R279	*310-0540-00	30 Ω	2 W		Prec	1%
R290	315-0104-00	100 k	1/4 W			5%
R293	322-0357-00	51.1 k	1/4 W		Prec	1%
R302	315-0473-00	47 k	1/4 W			5%
R304	315-0623-00	62 k	1/4 W			5%
R305	315-0124-00	120 k	1/4 W			5%
R307	315-0272-00	2.7 k	1/4 W			5%
R308	311-0170-00	20 k		Var		
R311	321-0191-00	953 Ω	1/8 W		Prec	1%
R312	308-0398-00	13.3 k	2 W		WW	1/2%
R313	308-0398-00	13.3 k	2 W		WW	1/2%
R314	308-0398-00	13.3 k	2 W		WW	1/2%
R323	308-0397-00	12.5 k	2 W		WW	1/2%
R325	311-0442-00	250 Ω		Var		
R326	323-0217-00	1.78 k	1/2 W		Prec	1%
R327	321-0269-00	6.19 k	1/8 W		Prec	1%
R331	315-0823-00	82 k	1/4 W			5%
R332	321-0184-00	806 Ω	1/8 W		Prec	1%
R334	315-0101-00	100 Ω	1/4 W			5%
R335A	323-0636-01	50 k	1/2 W		Prec	1/2%
R335B	323-0721-01	12.5 k	1/2 W		Prec	1/2%
R335C	323-0720-01	5.556 k	1/2 W		Prec	1/2%
R335D	323-0719-01	2.631 k	1/2 W		Prec	1/2%
R335E	323-0194-01	1.02 k	1/2 W		Prec	1/2%
R335F	323-1164-01	505 Ω	1/2 W		Prec	1/2%
R335G	323-0717-01	251.3 Ω	1/2 W		Prec	1/2%
R335H	323-0716-01	100.2 Ω	1/2 W		Prec	1/2%
R335J	323-0626-01	50 Ω	1/2 W		Prec	1/2%

Electrical Parts List—Type 1A7

Resistors (Cont'd)

Ckt. No.	Tektronix Part No.		Description			S/N Range
R343	315-0753-00	75 k	1/4 W			5%
R345	311-0551-00	500 k		Var		
R354	321-0281-00	8.25 k	1/8 W		Prec	1%
R358	321-0243-00	3.32 k	1/8 W		Prec	1%
R359	321-0184-00	806 Ω	1/8 W		Prec	1%
R360†	311-0399-00	7 k		Var		
R363	322-0336-00	30.9 k	1/4 W		Prec	1%
R364	315-0273-00	27 k	1/4 W			5%
R372	322-0481-00	1 MΩ	1/4 W		Prec	1%
R373	315-0474-00	470 k	1/4 W			5%
R375	311-0225-00	2X100 k		Var		
R376	315-0393-00	39 k	1/4 W			5%
R378	315-0474-00	470 k	1/4 W			5%
R379	315-0470-00	47 Ω	1/4 W			5%
R380	311-0225-00	2X100 k		Var		
R381	315-0393-00	39 k	1/4 W			5%
R402	315-0473-00	47 k	1/4 W			5%
R404	315-0623-00	62 k	1/4 W			5%
R405	315-0124-00	120 k	1/4 W			5%
R407	315-0242-00	2.4 k	1/4 W			5%
R411	321-0191-00	953 Ω	1/8 W		Prec	1%
R412	308-0398-00	13.3 k	2 W		WW	1/2%
R413	308-0398-00	13.3 k	2 W		WW	1/2%
R414	308-0398-00	13.3 k	2 W		WW	1/2%
R423	308-0397-00	12.5 k	2 W		WW	1/2%
R431	315-0823-00	82 k	1/4 W			5%
R432	321-0184-00	806 Ω	1/8 W		Prec	1%
R443	315-0753-00	75 k	1/4 W			5%
R454	321-0281-00	8.25 k	1/8 W		Prec	1%
R458	321-0243-00	3.32 k	1/8 W		Prec	1%
R459	321-0184-00	806 Ω	1/8 W		Prec	1%
R473	315-0474-00	470 k	1/4 W			5%
R478	315-0474-00	470 k	1/4 W			5%
R479	315-0470-00	47 Ω	1/4 W			5%
R490	311-0551-00	500 k		Var		
R491	325-0005-00	1.985 MΩ	1/2 W		Prec	1/2%
R492	322-0481-00	1 MΩ	1/4 W		Prec	1%
R494	301-0683-00	68 k	1/2 W			5%
R500	311-0564-00	15 Ω		Var		
R501	322-0212-08	1.58 k	1/4 W		Prec	1%
R502	321-0188-08	887 Ω	1/8 W		Prec	1%
R503	301-0114-00	110 k	1/2 W			5%
R504	315-0184-00	180 k	1/4 W			5%
R507	322-0225-00	2.15 k	1/4 W		Prec	1%
R512	308-0252-00	390 Ω	3 W		WW	5%

†R360 and SW360 furnished as a unit.

Resistors (Cont'd)

Ckt. No.	Tektronix Part No.		Description		S/N Range
R513	308-0314-00	680 Ω	3 W	WW	5%
R515	308-0313-00	20 k	3 W	WW	1%
R519	308-0029-00	400 Ω	20 W	WW	5%
R521	322-0337-00	31.6 k	1/4 W	Prec	1%
R522	321-0376-00	80.6 k	1/8 W	Prec	1%
R523	321-0376-00	80.6 k	1/8 W	Prec	1%
R524	321-0341-00	34.8 k	1/8 W	Prec	1%
R525	323-0391-00	115 k	1/2 W	Prec	1%
R527	322-0301-00	13.3 k	1/4 W	Prec	1%
R528	323-0297-00	12.1 k	1/2 W	Prec	1%

Switches

	Unwired	Wired	
SW101	260-0600-00		Lever, AC-GND-DC (+INPUT)
SW105	260-0719-00	*262-0735-00	Rotary, VOLTS/CM
SW155	260-0643-00		Toggle, DC OFFSET ON-OFF
SW201	260-0600-00		Lever, AC-GND-DC (-INPUT)
SW330A } SW330B } SW360†	260-0718-00	*262-0736-00	Rotary LOW FREQ 3 dB POINT HIGH FREQ 3 db POINT
	311-0399-00		

Test Points

TP523	*214-0579-00	Pin, test point
TP524	*214-0579-00	Pin, test point
TP525	*214-0579-00	Pin, test point
TP528	*214-0579-00	Pin, test point

Electron Tubes

V124 } V134 } V224 } V234 } V493	*157-0108-00	8393, aged (matched set of four)
	154-0323-00	6CW4

†SW360 and R360 furnished as a unit.

SECTION 8

MECHANICAL PARTS LIST

A list of abbreviations and symbols used in this section will be found immediately preceding Section 7. Parts ordering information is also located immediately preceding Section 7.

Mechanical Parts List—Type 1A7

FRONT

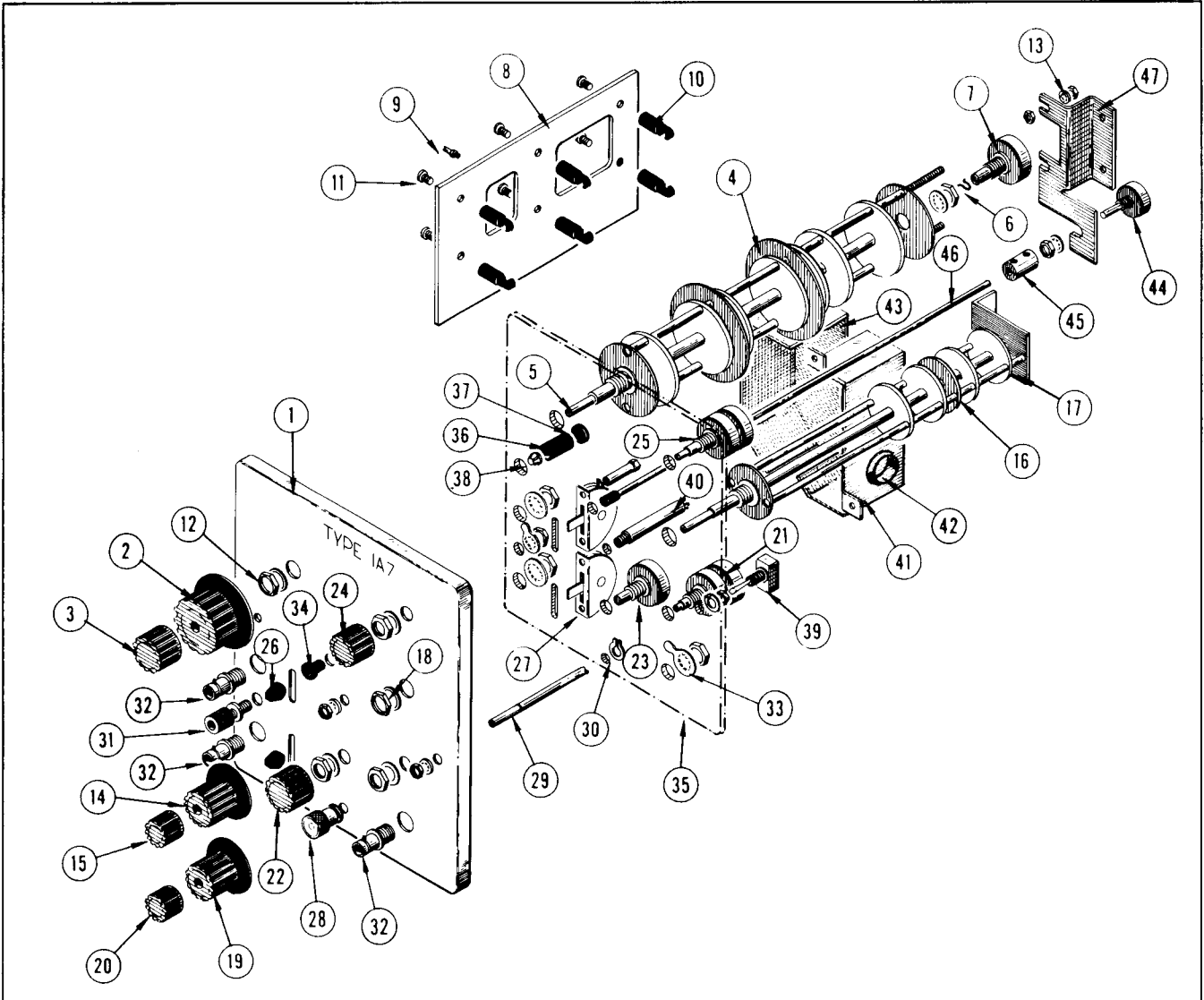

REF. NO.	PART NO.	SERIAL/MODEL NO.		QTY.	DESCRIPTION
		EFF.	DISC.		
1	333-0787-00			1	PANEL, front
2	366-0144-00			1	KNOB, charcoal — VOLTS/CM
	- - - - -			-	knob includes:
	213-0004-00			1	SCREW, set, 6-32 x 3/16 inch, HSS
3	366-0038-00			1	KNOB, red — VARIABLE
	- - - - -			-	knob includes:
	213-0004-00			1	SCREW, set, 6-32 x 3/16 inch, HSS
4	262-0735-00			1	SWITCH, wired — VOLTS/CM
	- - - - -			-	switch includes:
	260-0719-00			1	SWITCH, unwired — VOLTS/CM
	131-0371-00			9	CONNECTOR, 1 contact (not shown)
5	384-0366-00			1	SHAFT, inter-switch
6	376-0014-00			1	PIN, coupling
7	- - - - -			1	POT
	- - - - -			-	mounting hardware: (not included w/pot alone)
	210-0012-00			1	LOCKWASHER, internal, pot
	210-0413-00			2	NUT, hex., 3/8-32 x 1/2 inch

FRONT (Cont'd)

REF. NO.	PART NO.	SERIAL/MODEL NO.		QTY.	DESCRIPTION
		EFF.	DISC.		
8	670-0084-00			1	ASSEMBLY, ATTENUATOR BOARD
	- - - - -			-	assembly includes:
	388-0660-00			1	BOARD, etched-wiring, unwired
	- - - - -			-	board includes:
9	131-0285-00			4	CONNECTOR, slotted terminal lug
	- - - - -			-	mounting hardware: (not included w/assembly)
10	352-0022-00			6	HOLDER, nylon
11	211-0116-00			6	SCREW, sems 4-40 x 5/16 inch, PHB
	- - - - -			-	mounting hardware: (not included w/switch)
12	210-0012-00			1	LOCKWASHER, internal, pot
	210-0413-00			1	NUT, hex., 3/8-32 x 1/2 inch
	210-0840-00			1	WASHER, .390 ID x 9/16 inch OD
13	210-0006-00			2	LOCKWASHER, internal, #6
	210-0449-00			4	NUT, hex., 5-40 x 1/4 inch
14	366-0146-00			1	KNOB, charcoal — LOW FREQ 3 dB POINT
	- - - - -			-	knob includes:
	213-0004-00			1	SCREW, set, 6-32 x 3/16 inch, HSS
15	366-0177-00			1	KNOB, red — HIGH FREQ 3 dB POINT
	- - - - -			-	knob includes:
	213-0004-00			1	SCREW, set, 6-32 x 3/16 inch, HSS
16	262-0736-00			1	SWITCH, wired — HIGH & LOW FREQ
	- - - - -			-	switch includes:
	260-0718-00			1	SWITCH, unwired — HIGH & LOW FREQ
	131-0371-00			6	CONNECTOR, 1 contact
17	407-0169-00			1	BRACKET
	210-0586-00			2	NUT, keps, 4-40 x 1/4 inch
	- - - - -			-	mounting hardware: (not included w/switch)
18	210-0840-00			1	WASHER, .390 ID x 9/16 inch OD
	210-0413-00			1	NUT, hex., 3/8-32 x 1/2 inch
	210-0803-00			2	WASHER, 6L
	211-0504-00			2	SCREW, 6-32 x 1/4 inch, PHS phillips
19	366-0142-00			1	KNOB, charcoal — DC OFFSET
	- - - - -			-	knob includes:
	213-0004-00			1	SCREW, set, 6-32 x 3/16 inch, HSS
20	366-0081-00			1	KNOB, red — FINE
	- - - - -			-	knob includes:
	213-0004-00			1	SCREW, set, 6-32 x 3/16 inch, HSS
21	- - - - -			1	POT
	- - - - -			-	mounting hardware: (not included w/pot)
	210-0840-00			1	WASHER, .390 ID x 9/16 inch OD
	210-0413-00			1	NUT, hex., 3/8-32 x 1/2 inch
22	366-0113-00			1	KNOB, charcoal — STEP ATTEN DC BAL
	- - - - -			-	knob includes:
	213-0004-00			1	SCREW, set, 6-32 x 3/16 inch, HSS
23	- - - - -			1	POT
	- - - - -			-	mounting hardware: (not included w/pot)
	210-0840-00			1	WASHER, .390 ID x 9/16 inch OD
	210-0413-00			1	NUT, hex., 3/8-32 x 1/2 inch

Mechanical Parts List—Type 1A7

FRONT (Cont'd)

REF. NO.	PART NO.	SERIAL/MODEL NO.		QTY.	DESCRIPTION
		EFF.	DISC.		
24	366-0113-00			1	KNOB, charcoal — POSITION
	- - - - -			-	knob includes:
	213-0004-00			1	SCREW, set, 6-32 x 3/16 inch, HSS
25	- - - - -			1	POT
	- - - - -			-	mounting hardware: (not included w/pot)
	210-0840-00			1	WASHER, .390 ID x 7/16 inch OD
	210-0413-00			1	NUT, hex., 3/8-32 x 1/2 inch
26	366-0215-00			2	KNOB, lever, gray — AC-GND-DC
27	260-0600-00			2	SWITCH, lever, input — AC-GND-DC
	- - - - -			-	mounting hardware for each: (not included w/switch)
	220-0413-00			2	NUT, switch mounting, 3/16 inch hex. rod, 4-40
28	366-0125-00			1	KNOB, plug-in securing
	- - - - -			-	knob includes:
	213-0004-00			1	SCREW, set, 6-32 x 3/16 inch, HSS
	210-0894-00			1	WASHER, plastic, .190 ID x 7/16 inch OD
29	384-0510-00			1	ROD, securing
	- - - - -			-	rod includes:
30	354-0025-00			1	RING, retaining
31	129-0053-00			1	ASSEMBLY, binding post
	- - - - -			-	assembly includes:
	355-0507-00			1	STEM, binding post
	200-0103-00			1	CAP, binding post
	- - - - -			-	mounting hardware: (not included w/assembly)
	210-0223-00			1	LUG, solder, V4
	210-0455-00			1	NUT, hex., 1/4-28 — 3/8 x 3/32 inch
32	131-0106-00			3	CONNECTOR, coaxial, female, BNC (with hardware)
33	210-0255-00			1	LUG, solder, pot
34	358-0178-00	100	389	1	BUSHING, front panel, charcoal
	358-0216-00	390		1	BUSHING, front panel, gray
35	386-0220-00			1	PLATE, sub-panel
36	352-0084-00			1	HOLDER, neon
37	200-0609-00			1	CAP, holder
38	378-0541-00			1	LENS, neon
39	260-0643-00			1	SWITCH, toggle — DC OFFSET ON-OFF
	- - - - -			-	switch includes:
	- - - - -			2	NUT
	- - - - -			1	WASHER
	- - - - -			1	RING
40	- - - - -			1	POT
	- - - - -			-	mounting hardware: (not included w/pot)
	210-0971-00			1	WASHER, .219 ID x .350 inch OD
	210-0467-00			1	NUT, hex., 12-28 x 5/16 inch
41	407-0170-00			1	BRACKET, cap mounting
	- - - - -			-	mounting hardware: (not included w/bracket)
	210-0586-00			2	NUT, keps, 4-40 x 1/4 inch
42	354-0068-00			2	RING, securing, polyethylene

FRONT (Cont'd)

REF. NO.	PART NO.	SERIAL/MODEL NO.		QTY.	DESCRIPTION
		EFF.	DISC.		
43	337-0765-00 ----- 211-0007-00			1 - 2	SHIELD, cover mounting hardware: (not included w/shield) SCREW, 4-40 x 3/16 inch, PHS phillips
44	----- 210-0583-00 210-0046-00			1 - 1 1	POT mounting hardware: (not included w/pot) NUT, hex., 1/4-32 x 1/16 inch, double chamfered LOCKWASHER, .261 ID x .400 inch OD
45	376-0029-00 ----- 213-0075-00			1 - 2	COUPLING, shaft coupling includes: SCREW, set, 4-40 x 3/32 inch, HSS
46	384-0375-01			1	SHAFT, extension, pot
47	407-0171-00 ----- 211-0507-00 210-0457-00			1 - 2 2	BRACKET mounting hardware: (not included w/bracket) SCREW, 6-32 x 5/16 inch, PHS phillips NUT, keps, 6-32 x 5/16 inch

CHASSIS & REAR

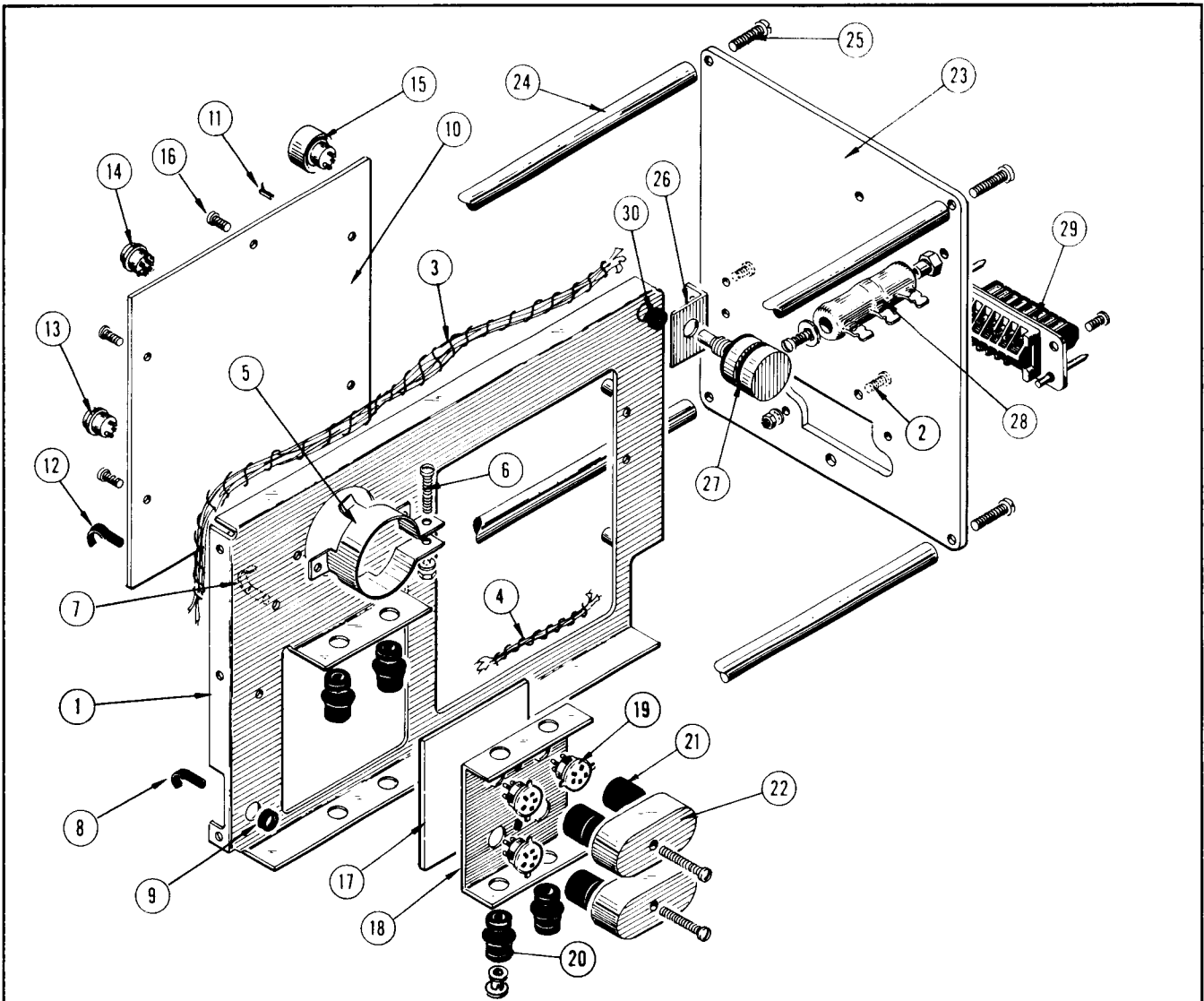

REF. NO.	PART NO.	SERIAL/MODEL NO.		QTY.	DESCRIPTION
		EFF.	DISC.		
1	441-0635-00			1	CHASSIS
2	211-0504-00			2	mounting hardware: (not included w/chassis) SCREW, 6-32 x 1/4 inch, PHS phillips
3	179-1006-00			1	CABLE HARNESS, #1
	131-0371-00			-	cable harness includes:
4	179-1007-00			17	CONNECTOR, single contact
	131-0371-00			1	CABLE HARNESS, #2
	343-0086-00			-	cable harness includes:
5	211-0507-00			3	CONNECTOR, single contact
	210-0202-00			1	CLAMP, cap mounting
	210-0006-00			-	mounting hardware: (not included w/clamp)
	210-0407-00			2	SCREW, 6-32 x 5/16 inch, PHS
				1	LUG, solder, #6
				1	LOCKWASHER, internal, #6
				2	NUT, hex., 6-32 x 1/4 inch

CHASSIS & REAR (Cont'd)

REF. NO.	PART NO.	SERIAL/MODEL NO.		QTY.	DESCRIPTION
		EFF.	DISC.		
6	211-0513-00			1	SCREW, 6-32 x 5/8 inch, PHS phillips
	210-0006-00			1	LOCKWASHER, internal, #6
	210-0407-00			1	NUT, hex., 6-32 x 1/4 inch
7	343-0089-00			1	CLAMP, cable, size D (large)
8	343-0088-00			3	CLAMP, cable, size C (small)
9	348-0056-00			2	GROMMET, delrin, 3/8 inch
10	670-0086-00			1	ASSEMBLY, MAIN AMPLIFIER BOARD
	- - - - -			-	assembly includes:
	388-0662-00			1	BOARD, etched-wiring
	- - - - -			-	board includes:
11	214-0506-00			45	PIN, connector
12	343-0088-00			1	CLAMP, cable, size C (small)
13	136-0183-00			13	SOCKET, 3 pin transistor
14	136-0186-00			4	SOCKET, 8 pin transistor
	200-0658-00			1	COVER, temperature stabilizer (not shown)
15	136-0125-00			1	SOCKET, 5 pin tube
	- - - - -			-	mounting hardware: (not included w/assembly)
16	211-0601-00			6	SCREW, assembly, 6-32 x .313 inch, PHB phillips w/washers
17	670-0085-00			1	ASSEMBLY, INPUT AMPLIFIER
	- - - - -			-	assembly includes:
	388-0661-00			1	BOARD, etched-wiring
18	407-0176-00			1	BRACKET
19	136-0226-00			4	SOCKET, 5 pin tube
20	348-0007-00			4	SHOCKMONUT
	361-0113-00			8	RESTRAINT, shockmount
21	377-0103-00			4	INSERT, heat stabilizer
22	200-0554-00			2	COVER, heat stabilizer
	- - - - -			-	mounting hardware for each: (not included w/cover alone)
	211-0516-00			1	SCREW, 6-32 x 7/8 inch, PHS phillips
23	386-0219-00			1	PLATE, rear
24	384-0631-00			4	ROD, spacer
	- - - - -			-	mounting hardware for each: (not included w/rod)
25	212-0044-00			1	SCREW, 8-32 x 1/2 inch, RHS phillips
26	406-0127-00			1	BRACKET, vertical position
	- - - - -			-	mounting hardware: (not included w/bracket)
	211-0507-00			2	SCREW, 6-32 x 5/16 inch, PHS phillips
	210-0006-00			2	LOCKWASHER, internal, #6
	210-0407-00			2	NUT, hex., 6-32 x 1/4 inch
27	- - - - -			1	POT
	- - - - -			-	mounting hardware: (not included w/pot)
	210-0012-00			1	LOCKWASHER, pot, internal
	210-0840-00			1	WASHER, .390 ID x 9/16 inch OD
	210-0413-00			1	NUT, hex., 3/8-32 x 1/2 inch
28	- - - - -			-	RESISTOR
	- - - - -			-	mounting hardware: (not included w/resistor)
	212-0004-00			1	SCREW, 8-32 x 5/16 inch, PHS phillips
	210-0808-00			1	WASHER, centering
	212-0037-00			1	SCREW, 8-32 x 1 3/4 inches, Fil HS phillips
	210-0462-00			1	NUT, hex., 8-32 x 1/2 inch

Mechanical Parts List—Type 1A7

CHASSIS & REAR (Cont'd)

REF. NO.	PART NO.	SERIAL/MODEL NO.		QTY.	DESCRIPTION
		EFF.	DISC.		
29	131-0017-00 - - - - - 210-0586-00 211-0007-00			1 - 2 2	CONNECTOR, 16 contact, male mounting hardware: (not included w/connector) NUT, keps, 4-40 x 1/4 inch SCREW, 4-40 x 1/4 inch, PHS
30	348-0055-00			1	GROMMET, delrin, 1/4 inch
--	070-0379-00			2	MANUAL, instruction (Standard Accessory, not shown)

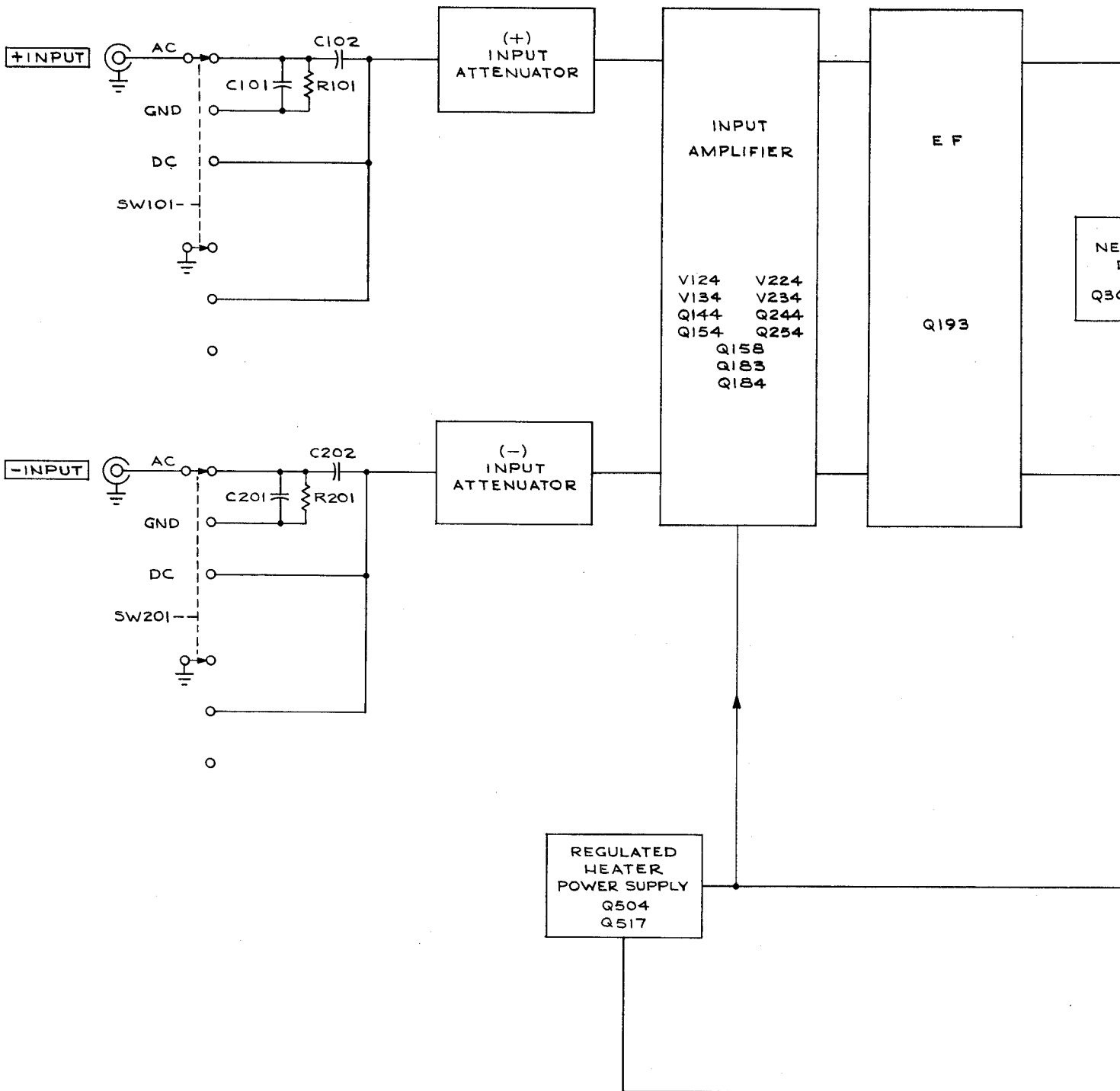

TYPE 1A7 PLUG-IN UNIT

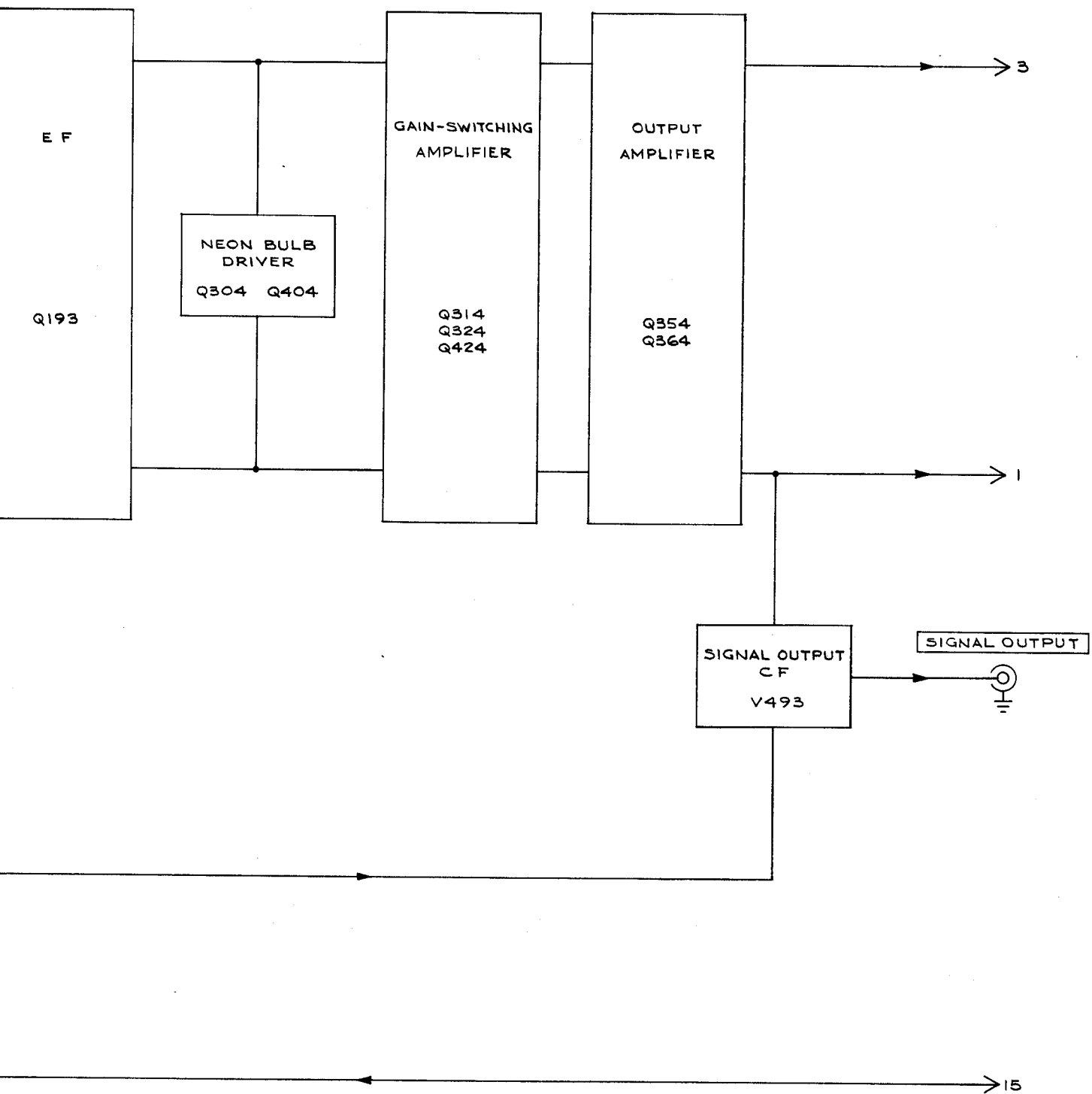

A

MR4
865
BLOCK DIAGRAM

IMPORTANT:

Circuit voltages were obtained with a non-loading voltmeter. All readings are in volts. All transistors are forward biased and the voltage drop between emitter and base is about 0.6 V. Voltage and waveform-amplitude measurements are not absolute and may vary from unit to unit. To obtain these measurements, a 30 inch flexible-cable extension (012-0038-00) was used to operate the Type 1A7 out of the oscilloscope plug-in compartment.

CAUTION

When connecting an extension between the Type 1A7 and a Type 544, 546 or 547 Oscilloscope, pull the oscilloscope plug-in sensing switch outward as soon as possible so the +75 volts is applied to the Type 1A7 regulated heater power supply. In all cases when troubleshooting, do not remove V493 while power is applied.

Actual waveform photographs are shown on the schematic diagrams. To show the waveforms in a time-related sequence, the test oscilloscope used for signal tracing was set for +Ext triggering on a 2-volt reference signal applied to the +INPUT connector of the Type 1A7. Refer to the Maintenance section for full details about signal tracing.

VOLTAGES AND WAVEFORMS were obtained under these conditions:

VOLTS/CM	.5
VARIABLE	CALIBRATED
POSITION	Midrange
HIGH FREQUENCY 3 dB POINT	500 kHz
LOW FREQUENCY 3 dB POINT	DC
AC-GND-DC (+INPUT)	GND (for voltages) AC (for waveforms)
AC-GND-DC (-INPUT)	GND
STEP ATTEN FINE	Midrange
DC OFFSET ON-OFF	OFF (ON, for Tables 1 and 2)

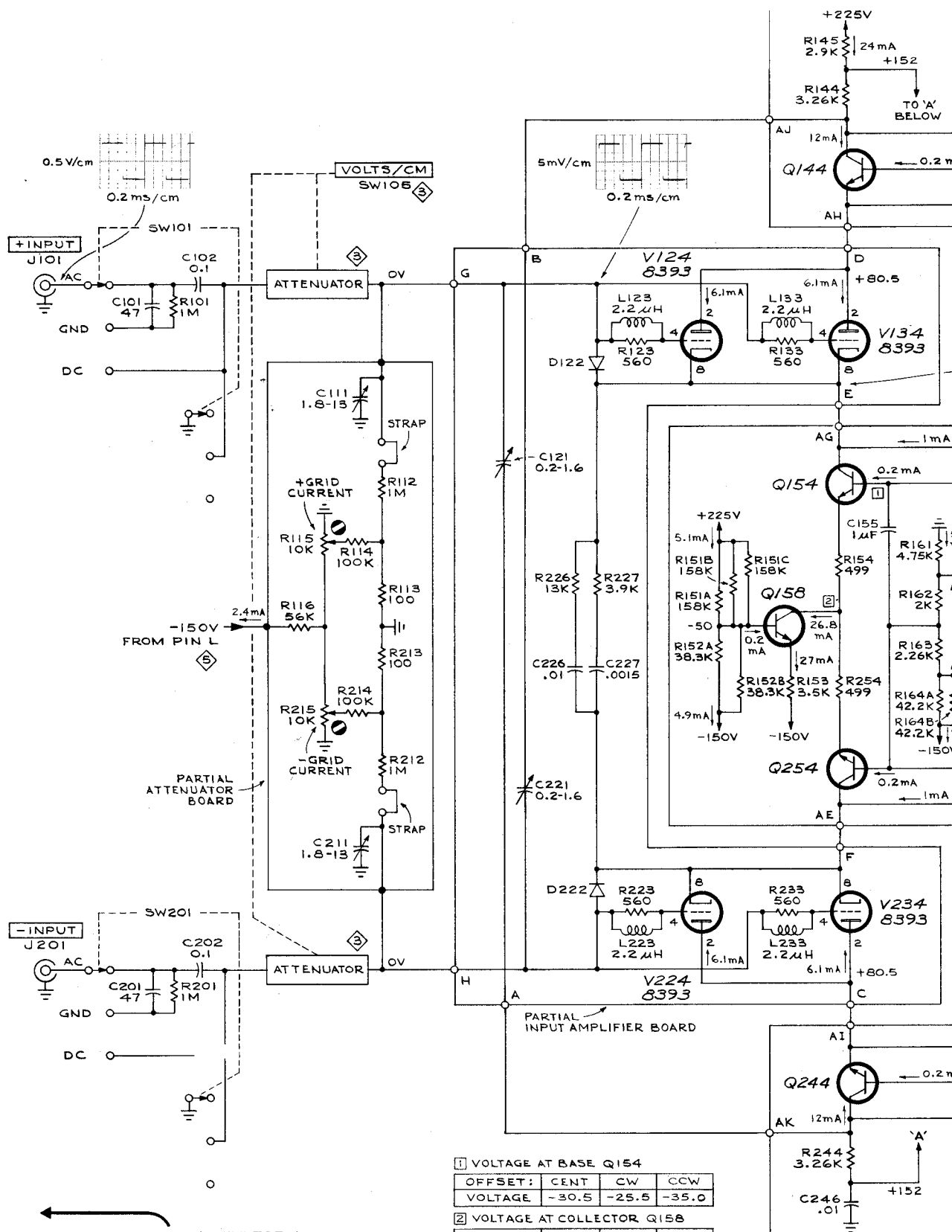

TYPE 1A7 PLUG-IN

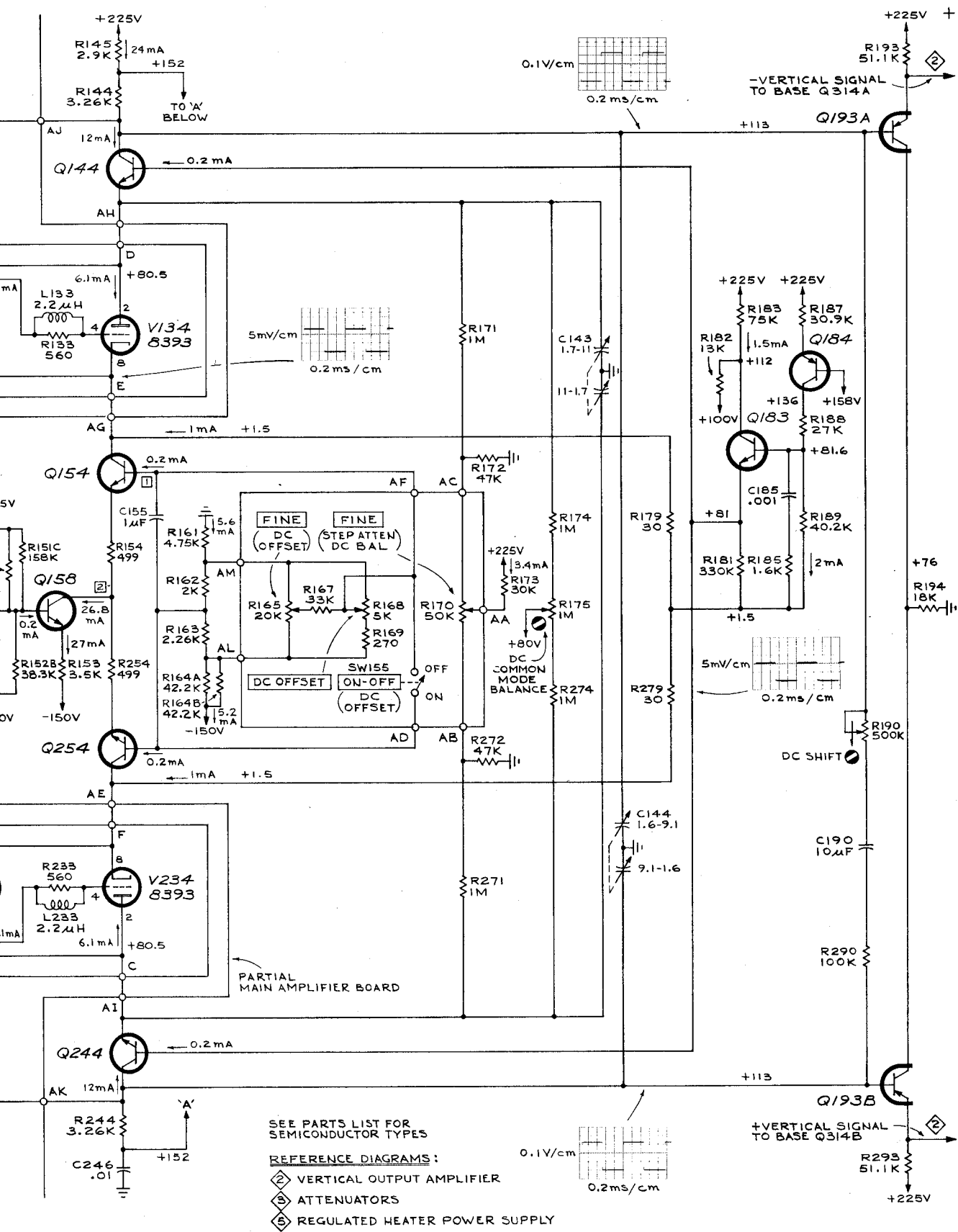

SEE PARTS LIST FOR SEMICONDUCTOR TYPES

REFERENCE DIAGRAMS :

- ② VERTICAL OUTPUT AMPLIFIER
- ③ ATTENUATORS
- ⑤ REGULATED HEATER POWER SUPPLY

VERTICAL INPUT AMPLIFIER ①

MRH
865

A

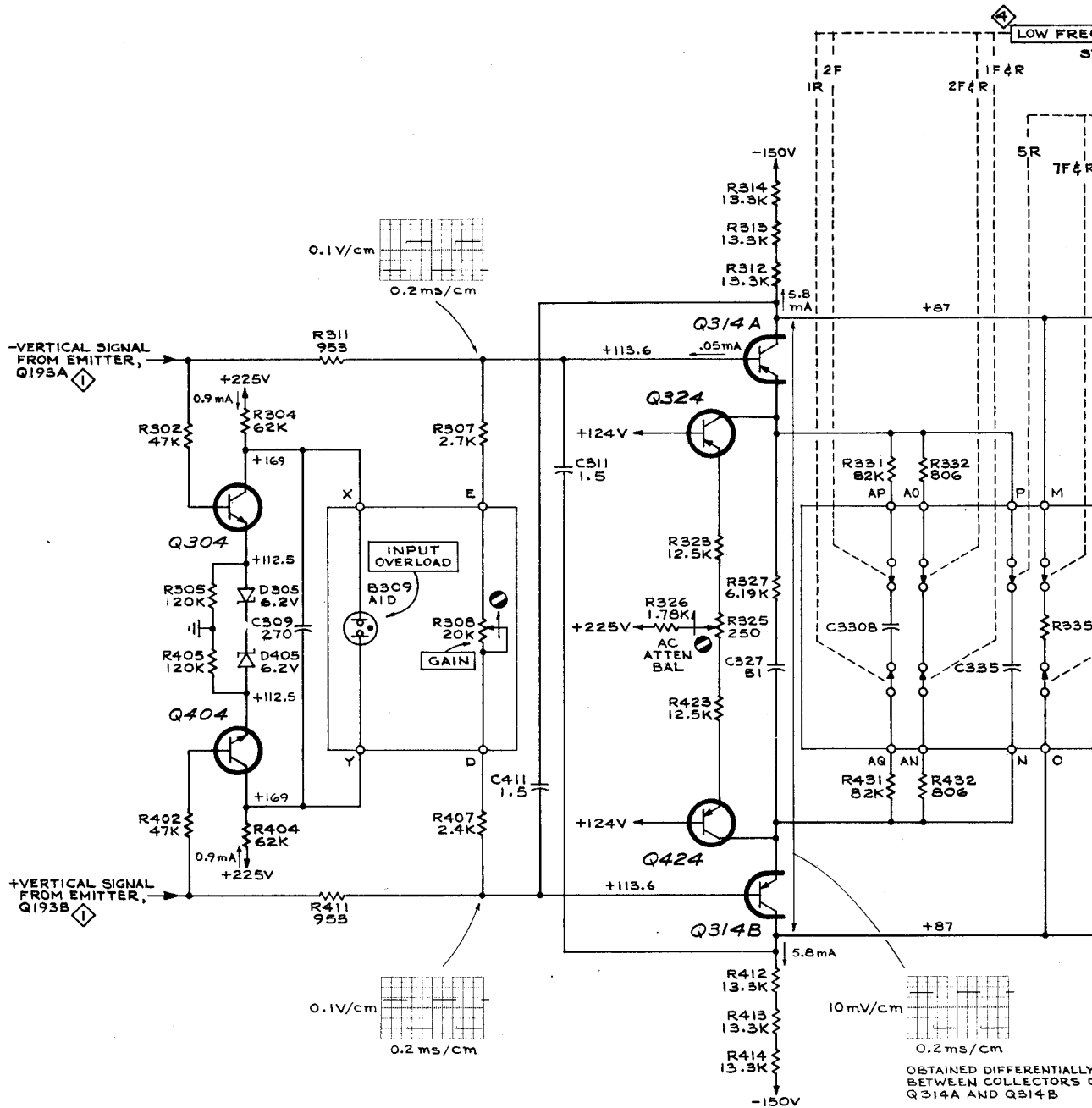

FOR VOLTAGE & WAVEFORM CONDITIONS
SEE INSIDE SECTION OF

SEE PARTS LIST FOR
SEMICONDUCTOR TYPES

REFERENCE DIAGRAMS:

- 1 VERTICAL INPUT AMPLIFIER
- 2 ATTENUATORS
- 3 BANDPASS SWITCHES
- 4 REGULATED HEATER POWER SUPPLY

TYPE 1A7 PLUG-IN

A

+

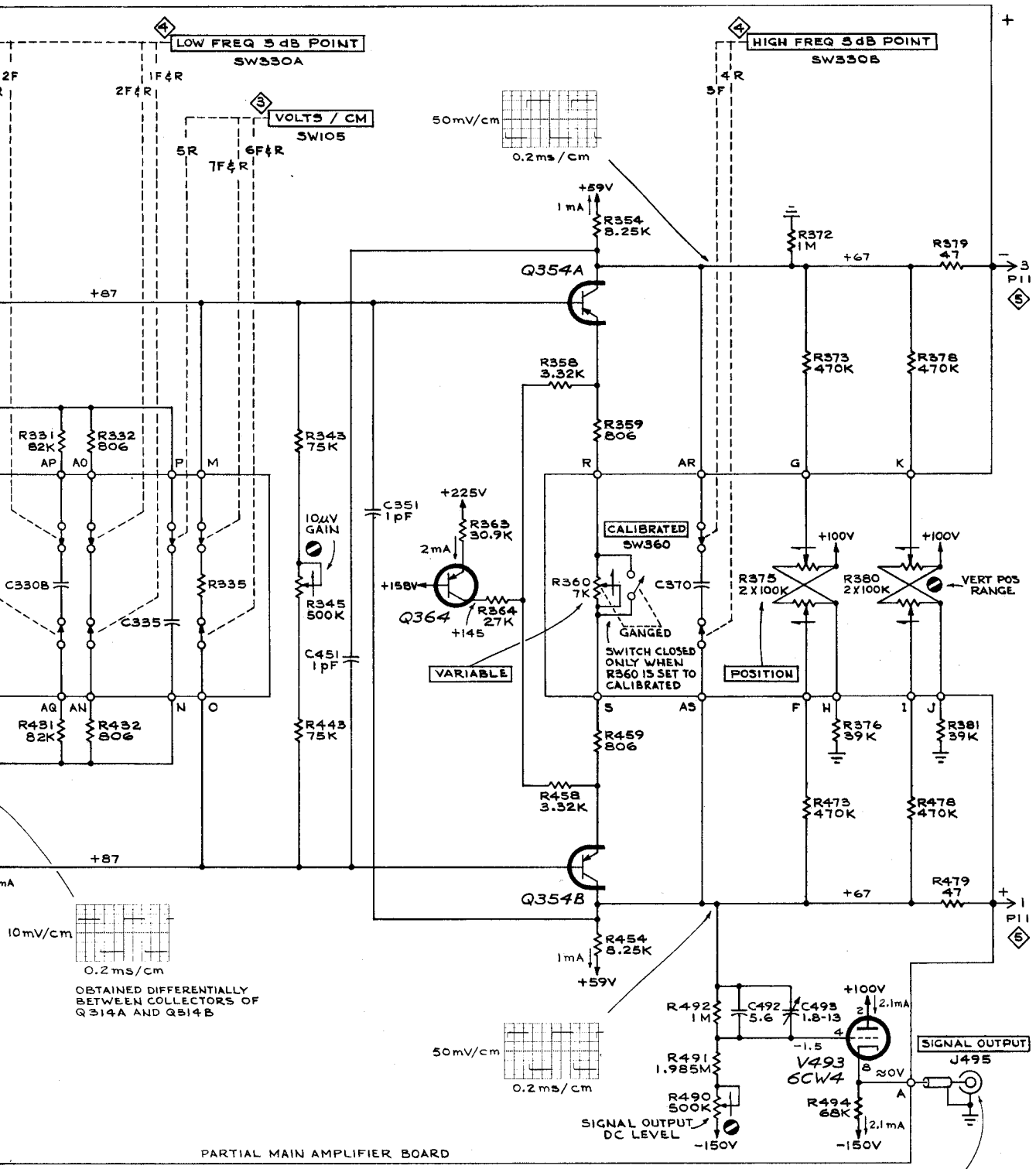

MRH 765
 VERTICAL OUTPUT AMPLIFIER ②

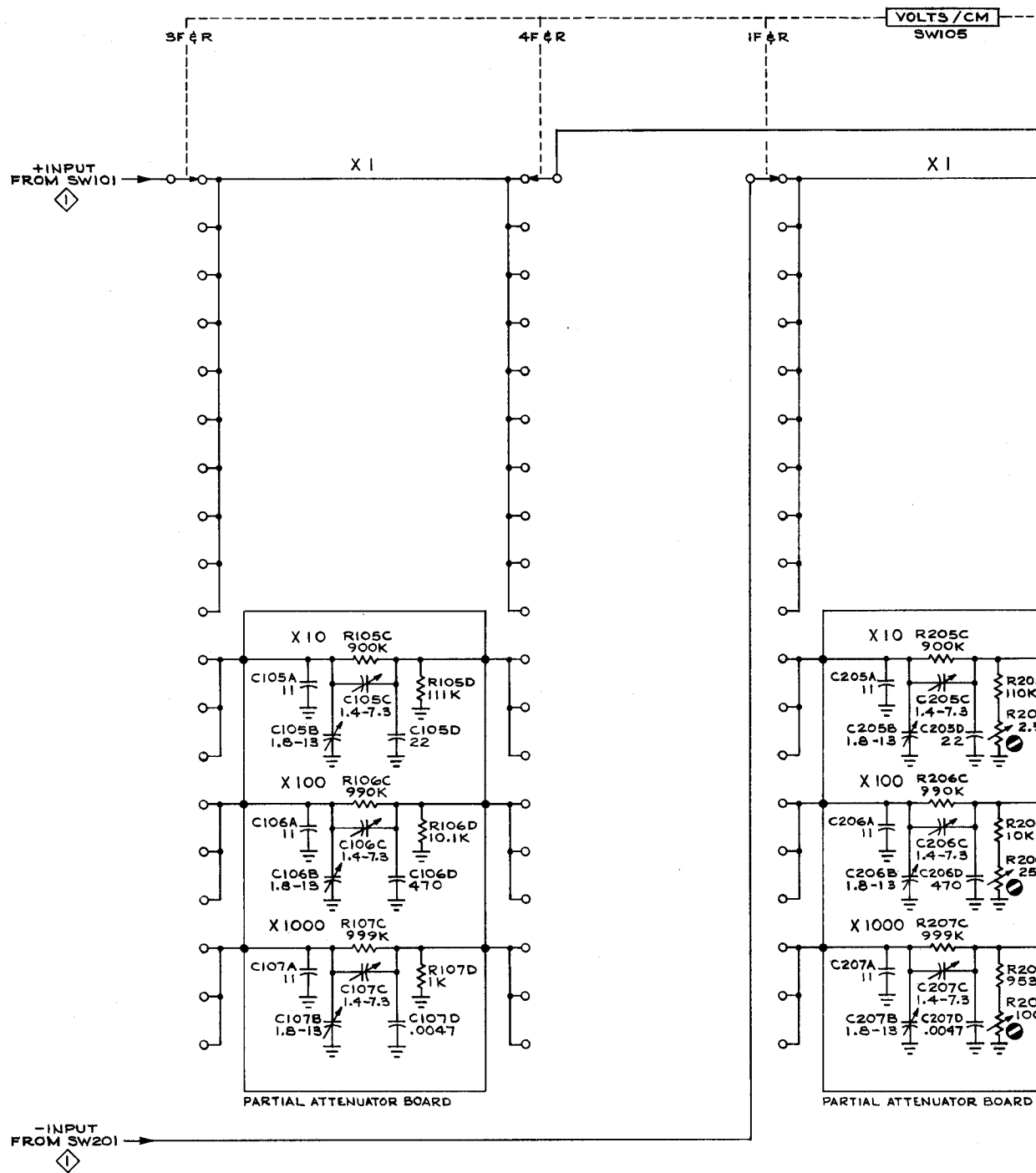

TYPE 1A7 PLUG-IN

A

+

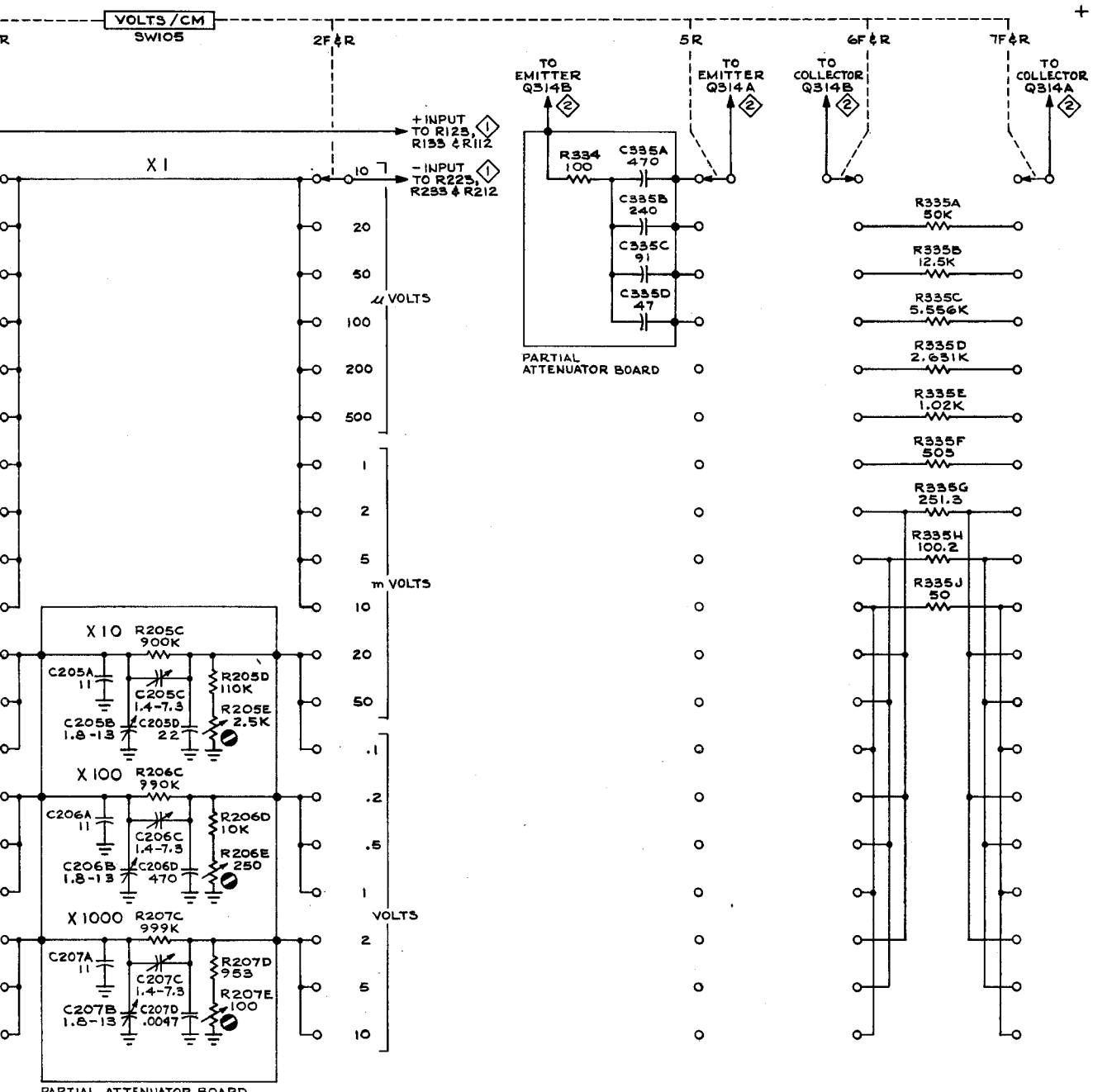

REFERENCE DIAGRAMS:

① VERTICAL INPUT AMPLIFIER

② VERTICAL OUTPUT AMPLIFIER

MRH
765

ATTENUATORS ③

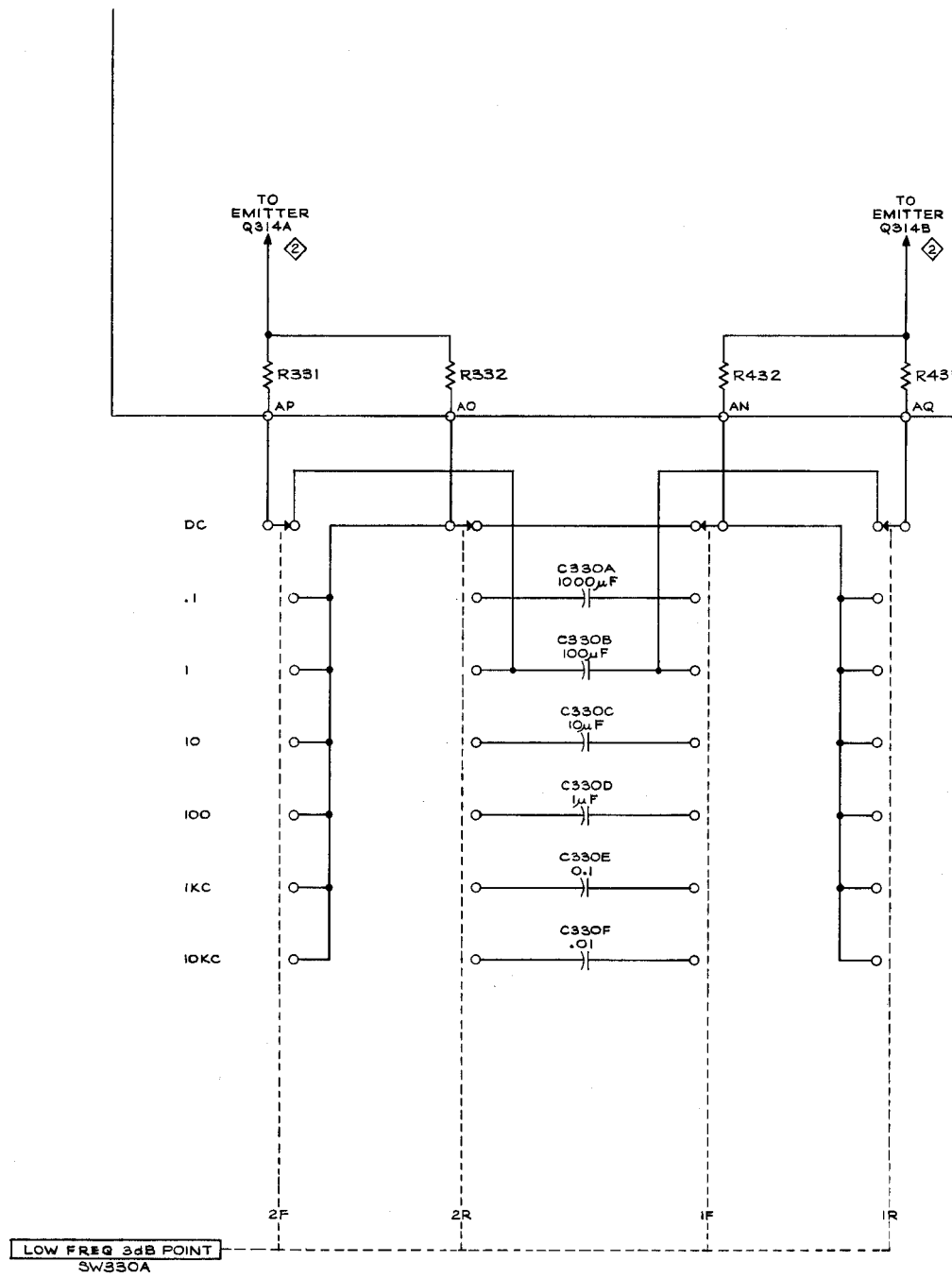

TYPE IA7 PLUG-IN

REFERENC
 2 VERTICAL

A

+

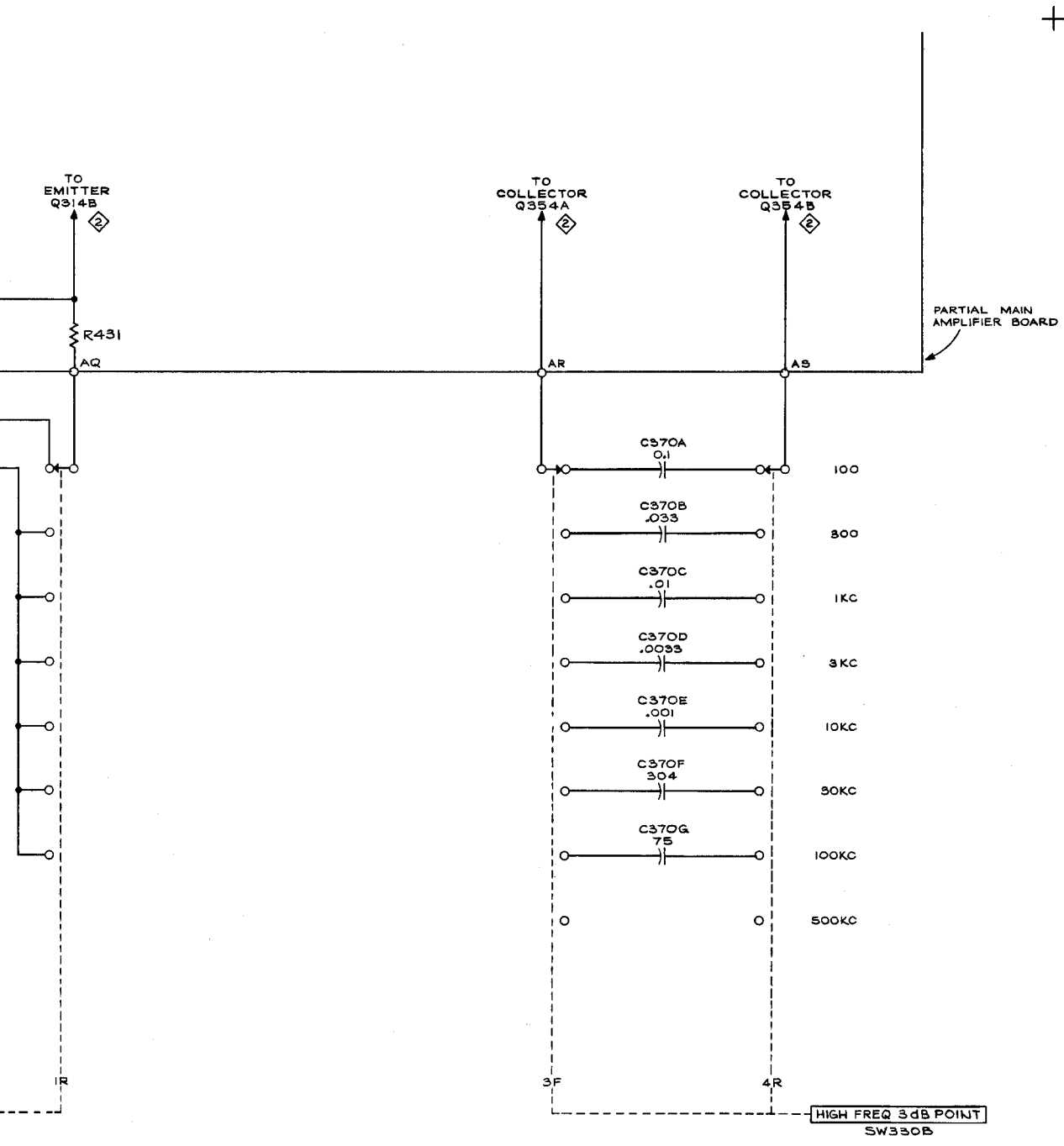

REFERENCE DIAGRAM

② VERTICAL OUTPUT AMPLIFIER

GTN
765

BANDPASS SWITCHES

④

A

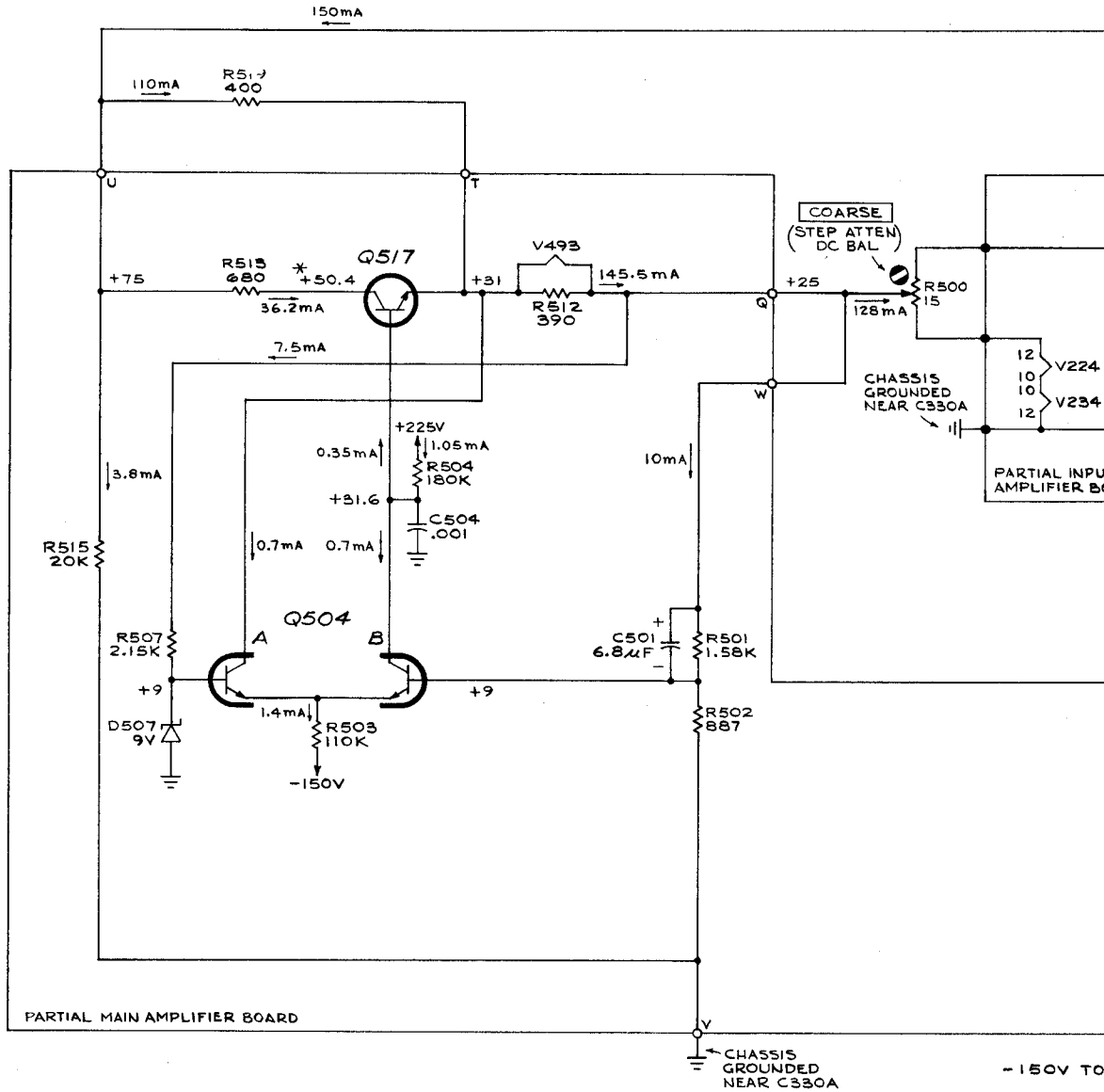

SEE PARTS LIST FOR SEMICONDUCTOR TYPES

REFERENCE DIAGRAMS:

- ① VERTICAL INPUT AMPLIFIER
- ② VERTICAL OUTPUT AMPLIFIER

FOR VOLTAGE CONDITIONS SEE INSIDE SECTION OF ①

*MAY VARY ±15V
() ACTUAL VOLTAGES

TYPE 1A7 PLUG-IN

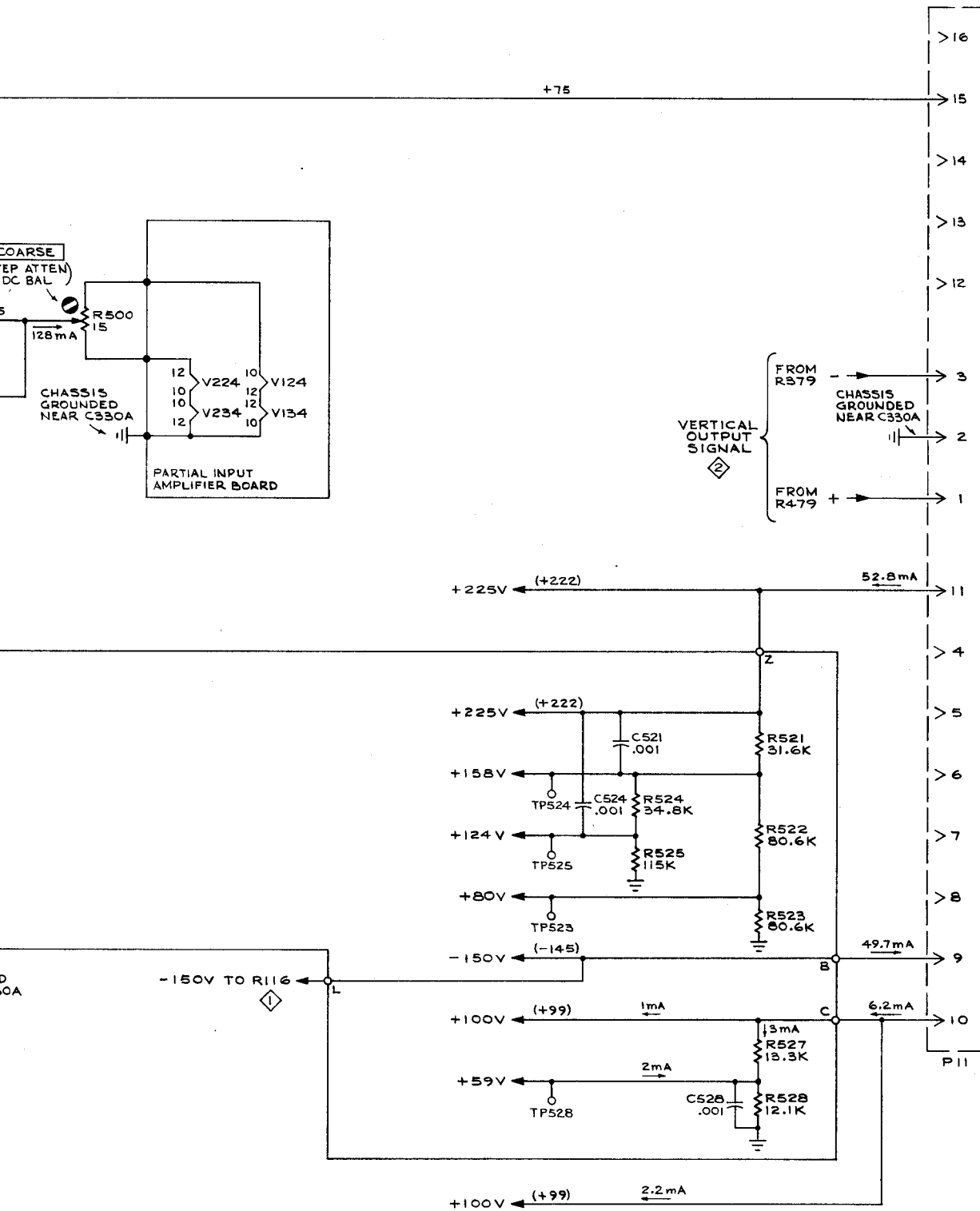

+

A₁

REGULATED HEATER POWER SUPPLY

MRH
765

5

MANUAL CHANGE INFORMATION

At Tektronix, we continually strive to keep up with latest electronic developments by adding circuit and component improvements to our instruments as soon as they are developed and tested.

Sometimes, due to printing and shipping requirements, we can't get these changes immediately into printed manuals. Hence, your manual may contain new change information on following pages. If it does not, your manual is correct as printed.